

Skydio 3D Scan

Skydio X10 Software Manual

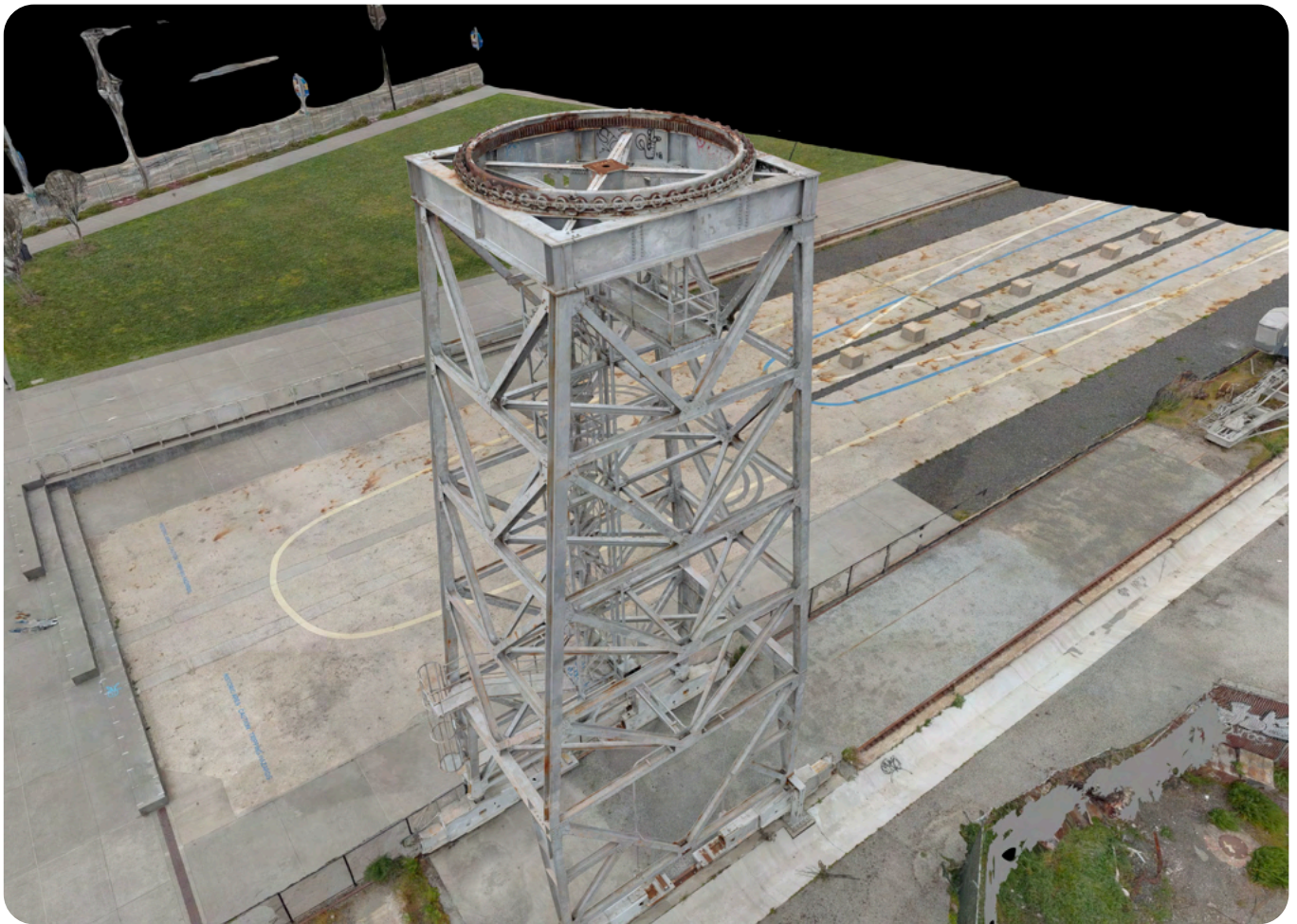



WARNING: Please read all documentation provided with your Skydio X10, including but not limited to the X10 Safety Guidelines in the Safety and Operating Guide: www.skydio.com/safety. Failure to follow any instructions or recommendations in our documentation may void the Skydio Limited Warranty.

Additional Resources

For the latest information about Skydio and our products, visit: www.skydio.com

Scan the QR codes to view more information about flying with Skydio X10.



Getting Started with Skydio X10



Flying with Skydio X10



Skydio X10 Maintenance



Skydio Safety and Operating Guide



Skydio Support



For legal, warranty and intellectual property information, visit: www.skydio.com/legal

Table of Contents

Flying Safely	01
Safety Guidelines	01
Getting Started	02
Skydio 3D Scan Overview	3
General Capture Modes	4
Required Software and Equipment	6
Formatting microSD Cards	7
How to Enable 3D Scan Mode	9
Scan Workflows	12
3D Capture Workflow	13
AR Coverage Mesh	42
Surface Capture Workflow	44
Upward Capture	65
Indoor Capture Workflow	68
Multi-Battery Scans	101
How to Change Batteries Mid-Scan	103
Onboard Modeling	108
Using the Model Viewer	109
Creating Onboard Models	110
Model Viewer Tools	116
Exporting Onboard Maps or Models	121

Scan Settings

122

Camera Settings	123
All Scan Modes	128
3D Capture and Indoor Capture Settings	131
Visual Geofence	134
Take Best Photo	137
Extend Volume	138
Optimize X, Y	139
Surface Capture Settings	140
Use Case Example Settings	142
Ground Sample Distance	146

Accessing Scan Data

150

3D Scan Files	151
File Types	152

Contingency Behaviors

154

Lost Connection and Low Battery	155
Environmental Factors	156

Safety Guidelines



WARNING: To avoid injury or damage to your drone, read the Skydio X10 Safety Guidelines in the Safety and Operating Guide.

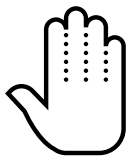

Keep your fingers away from moving propellers at all times.



Use caution around reflective surfaces (e.g., still water or mirrors) and small obstacles (e.g., thin branches, utility lines, or chain link fencing)

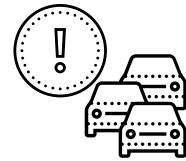

Skydio X10 does not avoid moving objects (e.g., vehicles).



Skydio X10 obstacle avoidance is off during GPS Only flight mode and can be impaired when in low light and poor visibility. Fly with extreme caution under these conditions.

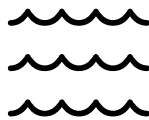

Before flying over water, ensure your drone has a strong GPS signal. Launch and land over a dry surface.



Skydio X10 is IP55 rated and able to fly in light to moderate precipitation in Standard or Low Light Flight modes, with obstacle avoidance disabled. Skydio X10 Controller is IP54 rated.



Clean all of the cameras before each flight so Skydio X10 can see clearly.

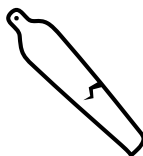

Check your propeller blades for damage before each flight.



Follow all civil aviation authority regulations, as well as all local, state, and federal laws.



Getting Started

Before you fly, read the Skydio X10 Operator Manual to learn how to fly and fully understand all autonomy features. Ensure both X10 and the controller are fully charged and paired.

This section covers

Skydio 3D Scan™ Overview

Capture Modes

Required Software and Equipment

How to Enable 3D Scan Mode

Skydio 3D Scan™ Overview

Skydio 3D Scan™ is first-of-its kind adaptive scanning software that automates data capture of any scene with comprehensive coverage and ultra-high resolution. 3D Scan allows crews to spend less time training pilots and more time performing higher quality inspections.

Skydio 3D Scan operates with no reliance on prior maps, magnetometer readings or active internet connectivity. Choose your Capture Type, specify the settings and area/structure to scan, and Skydio 3D Scan does the rest.

- Adaptively maps the scene and uses intelligent flight planning to build a live 3D model
- Autonomously captures all surfaces using an AI-driven and augmented reality (AR) workflow
- While onsite, create 3D models or 2D maps on the drone to review your scan



INFO: Map Capture is available with the baseline Skydio Autonomy features. For information about Map Capture, visit skydio.com/support.

General Capture Modes

3D Capture

Efficiently scan complex structures with 3D Capture.

Skydio assesses the scan volume and generates autonomous and adaptive flight patterns to ensure every angle of the structure is captured. Capture data can be used for inspection or to generate high-fidelity 3D models.

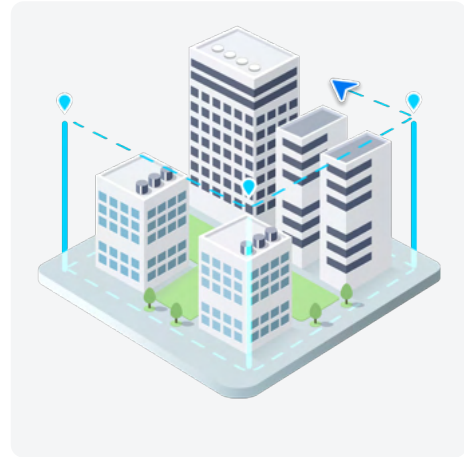

NOTE: 3D Capture is best for scanning structures such as machinery, bridges, architecture, and vehicles.

Surface Capture

Surface Capture is a planar scanning capability that captures imagery for orthomosaics and digital terrain models. This mode scans in a grid lawnmower pattern.

Use **Upward Capture** in this mode to capture the underside of structures.

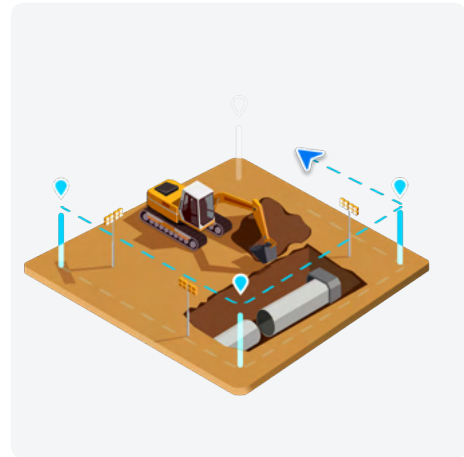

NOTE: Surface Capture is best for wide, flat area mapping. Use Surface Capture when you need a 2D orthomosaic map of areas such as accident sites or capturing the underside of a structure (e.g., under a bridge).

Indoor Capture

Scan interior spaces such as construction sites, factories, or warehouses with Indoor Capture.

The autonomous flight path is tailored to indoor environments, and default settings are optimized for safely and accurately performing indoor mapping missions. Designed for GPS-denied environments.



NOTE: *Indoor Capture allows you to work with two scan volumes: Inside Volume and Outside Volume.*



INFO: *All of the above scan modes are capable of operating in GPS-denied environments.*

Required Software and Equipment

Before you fly, read the Skydio X10 Operator Manual to learn how to fly and fully understand all autonomy features. Ensure both your drone and the controller are fully charged, and your controller is paired to your drone.

For Skydio manuals, visit skydio.com/manuals.



CAUTION: Always follow the [Skydio Safety and Operating Guide](#) when flying—avoid thin branches, thin wires, and large glass/reflective panes..

Software

- Skydio Flight Deck (included with the Skydio X10 Controller)
- Skydio 3D Scan™ software license

Equipment

To fly 3D Scan you will need:

- Skydio Skydio X10 Batteries
- Skydio Skydio X10 Controller
- 2x UHS Class 3 microSD cards (minimum 256 GB)

Formatting microSD Cards

Skydio requires two UHS Speed Class 3 (or faster) microSD cards to complete 3D Scans. Skydio X10 comes with these two cards pre-installed on the side of the drone.

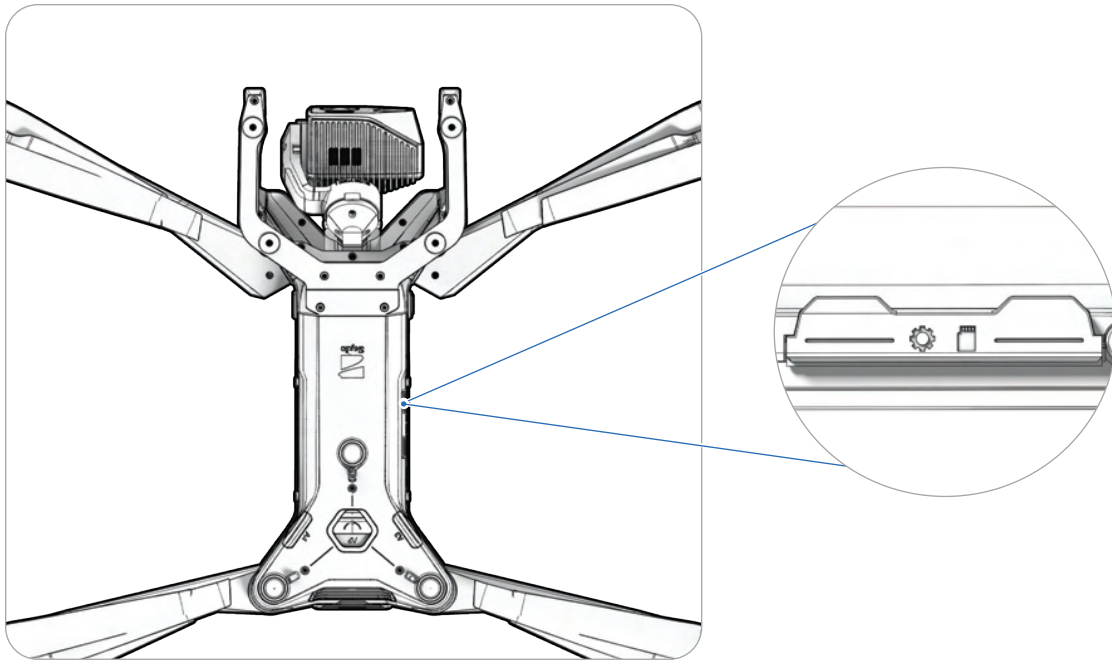

Skydio X10 cannot scan without properly formatted microSD cards. Format your cards before flying using **Manage Data** within the **Information** menu (Global Settings > Information > Devices > Manage Data).



NOTE: We test with and strongly recommend using [SanDisk Extreme PLUS](#) (256GB) microSD cards.

Flight Controls

Move through the scan workflow using the Skydio X10 Controller.

- The workflow pane will collapse when you are prompted to manually fly
- Flight Deck will display available controller shortcuts

1. Left joystick
2. Menu/Back button
3. C1 button¹
4. C2 button¹
5. C3 button¹
6. Power button
7. Launch/Return/Land button
8. Pause button
9. Directional pad (D-pad)
10. Right joystick
11. Controller cover/antennas
12. R1 button (Shutter)
13. Right wheel (Minimize/maximize workflow pane)
14. HDMI port
15. USB-C charge port
16. L1 button (Boost)
17. Left wheel¹
18. R2 button¹
19. Cooling fan
20. Neck strap² and tripod mount
21. L2 button¹

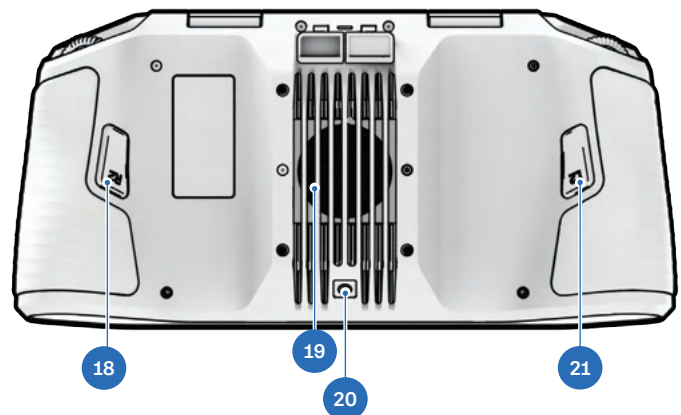
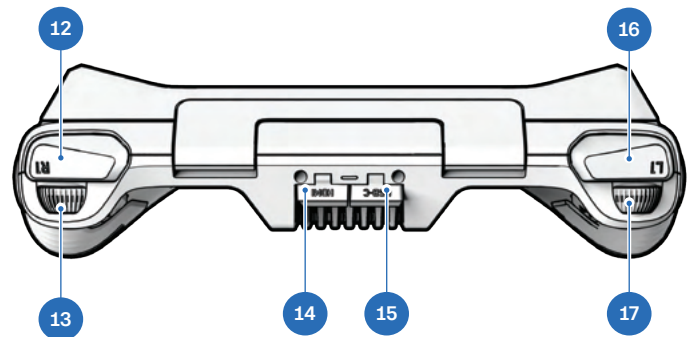
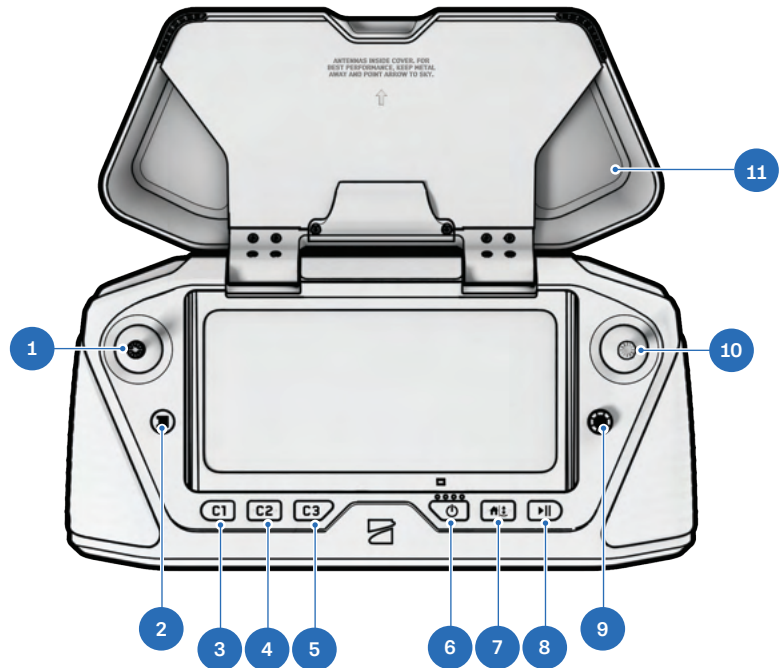

¹Customizable

²Neck strap sold separately

How to Enable 3D Scan Mode

Change Flight Mode

Before starting a scan, the drone must first **reboot to enter the 3D Scan Mode**. Skydio will remember your operating mode through power cycles, so you will only have to do this when switching between 3D Scan and Skills.

To change operating modes, you must enter 3D Scan while on the ground and connected to the drone.

Step 1 - Enter 3D Scan Flight Mode

Power on your drone and controller. Select **Switch Mode**. A menu will pop out from the right side displaying available Flight Modes.

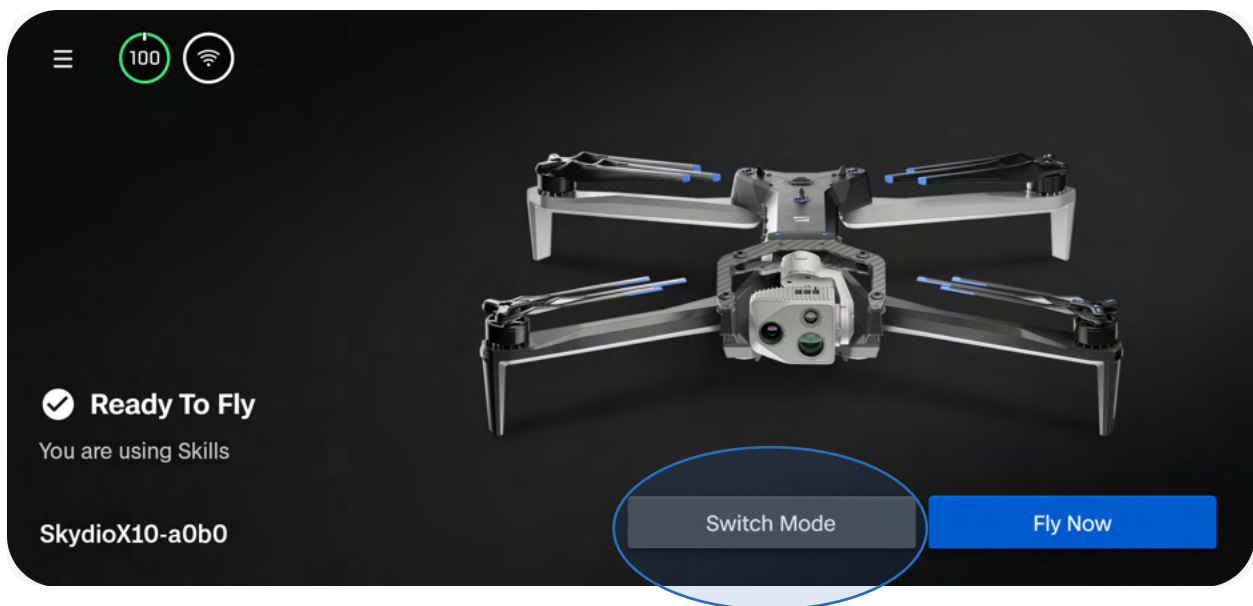

Getting Started

Step 2 - Select 3D Scan

Select **3D Scan**. When you return to the Gate Screen, you will see the subtitle, “You are using 3D Scan.”

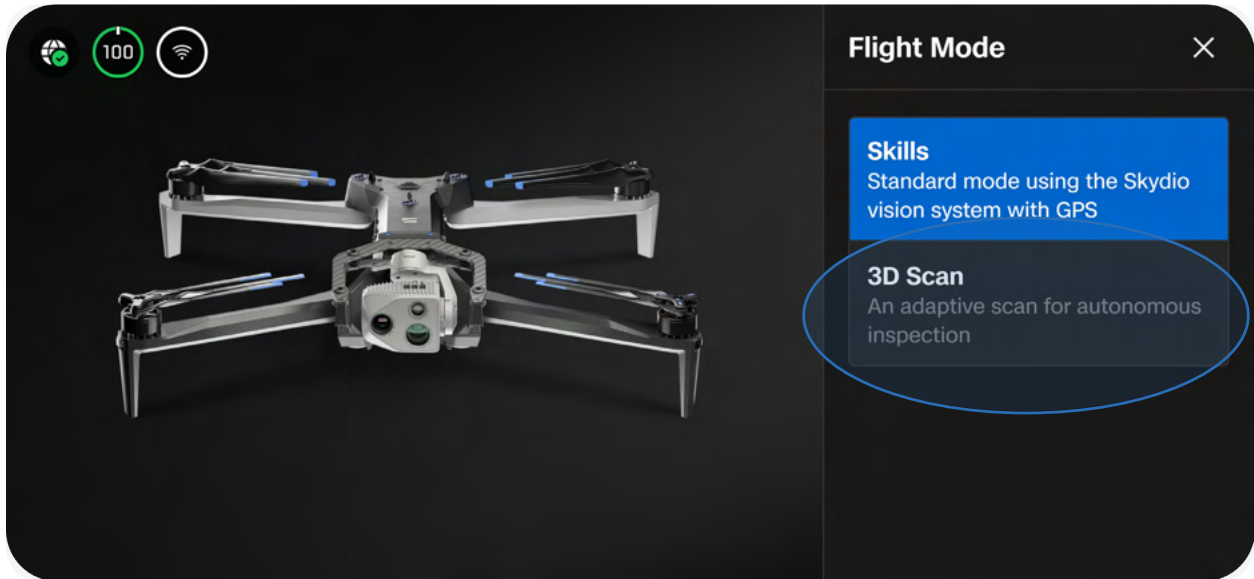

Getting Started

Step 3 - Begin flight

Two microSD cards are required. Ensure your **Logs Card has been formatted** before starting a scan. If you have not yet done so, a notification will display in the app. See the above microSD Card section in **Getting Started** for instructions on how to format.

Select **Fly Now** and select **Agree** to the disclaimer, acknowledging that you will comply with all relevant laws and regulations.



NOTE: You must exit 3D Scan to regain access to Flight Skills. To exit, first land the drone. Navigate back to the Gate Screen and change the Flight Mode to Skills.



Scan Workflows

Read step-by-step instructions that guide you through the setup process for each capture type.

This section covers

3D Capture Overview and Workflow

Augmented Reality (AR) Coverage Mesh

Surface Capture Overview and Workflow

Indoor Capture Overview and Workflow

3D Capture Workflow

Overview

Before you fly:

- GPS will be required for scans higher than 65 ft (20 m).
- If needed, you can move backwards and re-do any steps in the workflow. Doing so will reset the steps you have already completed and discard any media that has been captured.
- If you are flying with a Skydio VT300-Z / VT300-L you have the ability to enable thermal image capture in the thermal settings.

Refer to the table below for the default settings in this mode. For more detailed information about each setting, view the 3D Capture Settings section.

- Define the **Floor**, **Ceiling**, and **Wall Boundaries** to create your **Scan Volume**

Setting	Default
Strict Geofence	All bounds OFF by default
Extend Volume	Beyond Floor enabled
Gimbal angle	45°
Scan passes	Z, Y, X enabled
Overlap/sidelap	80/70
Speed <i>(applies when exploring and scanning)</i>	5.6 mph (2.5 m/s)
Other settings ON by default	Take Best Photo



TIP: *If you wish to capture the same structure with different GSD across various sections, or if you have a very large structure to scan, try breaking your scan into multiple smaller scans. For best results, launch as close as possible to the section of the structure you are scanning.*

Scan Setup

Step 1 - Scan Mode

Select **3D Capture** as the Scan Mode. Tap **Select Scan Mode** on the screen or use the right shoulder button on the controller to confirm your selection.

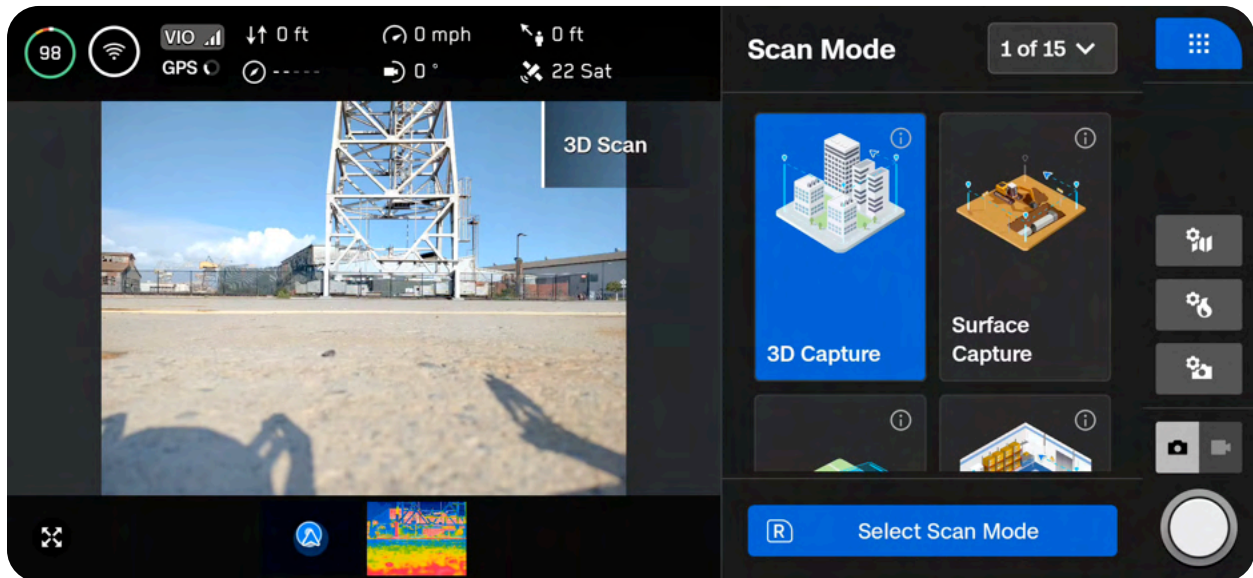

Step 2 - Scan Name (optional)

You may optionally rename your scan. The default scan name is composed of the scan mode you select followed by a UTC timestamp. Renaming the scan will replace the scan mode.

- Ex: 3D_Capture__2024-05-20T19-50-55.135854+00-00

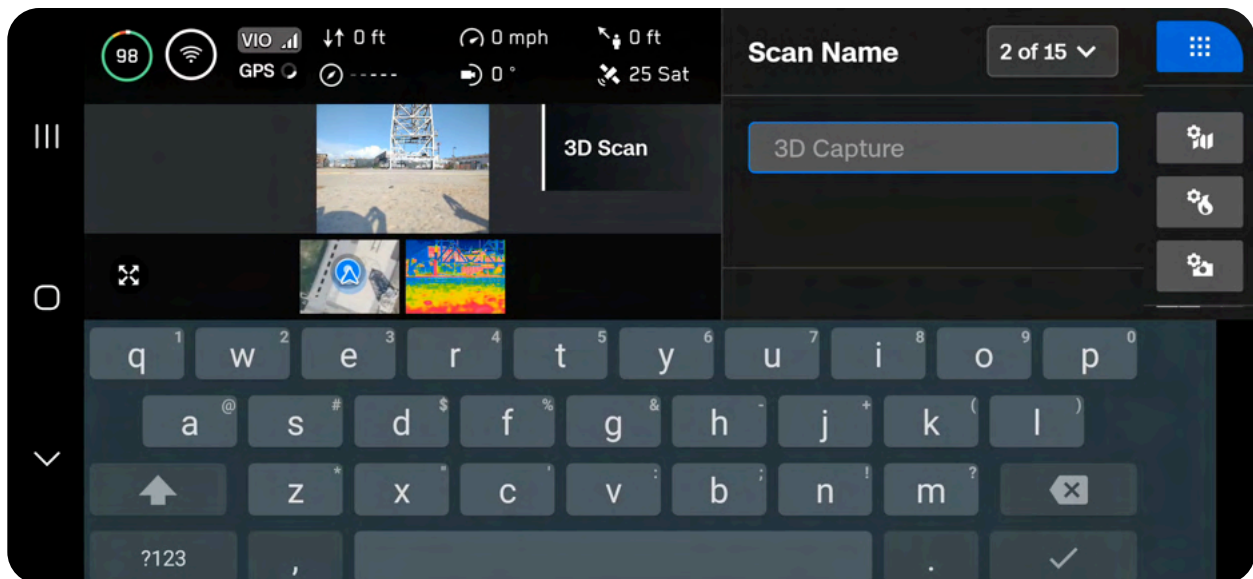
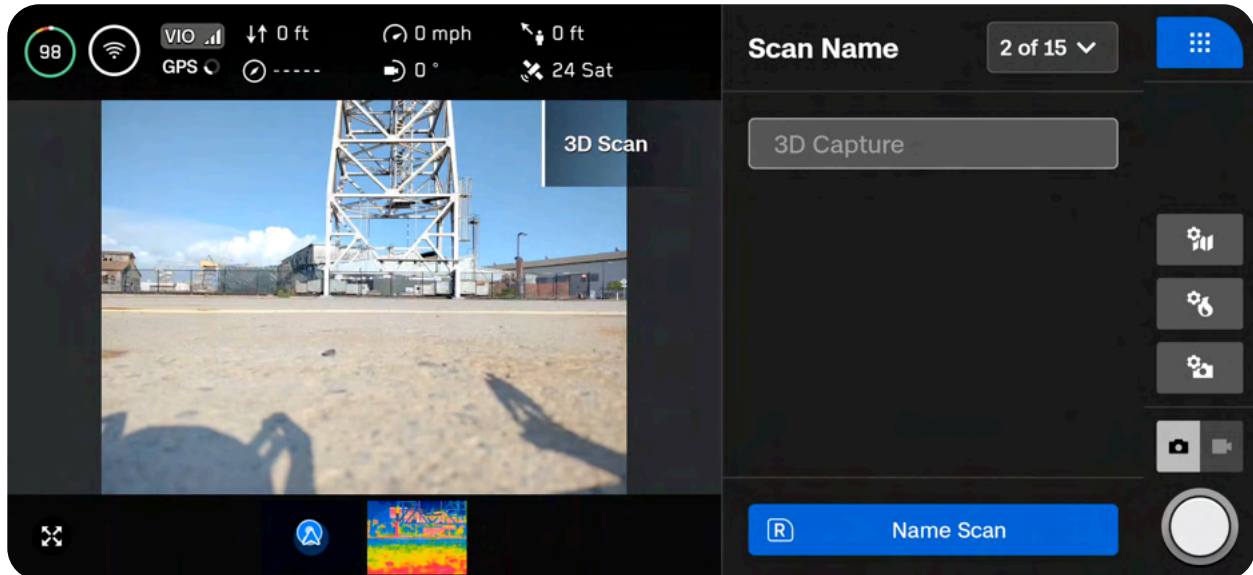

NOTE: Scan names must use American Standard Code for Information Interchange (ASCII) characters. You will be prevented from using unicode characters such as à, é, â, ü, ö, ä and the following symbols: < > : ; , \ | ? * & \$ { } ` “ Visit skydio.com/support for more information.

Step 3 - Launch

Drag the on-screen slider or press and hold the Launch/Land button on your controller to begin your flight. The drone will launch, automatically rotate 360 degrees, climb to 10 ft (3 m), and hover.

Take note of your launch orientation. If your scan requires multiple batteries, you will need to place the drone in the exact same location and orientation after replacing a battery.

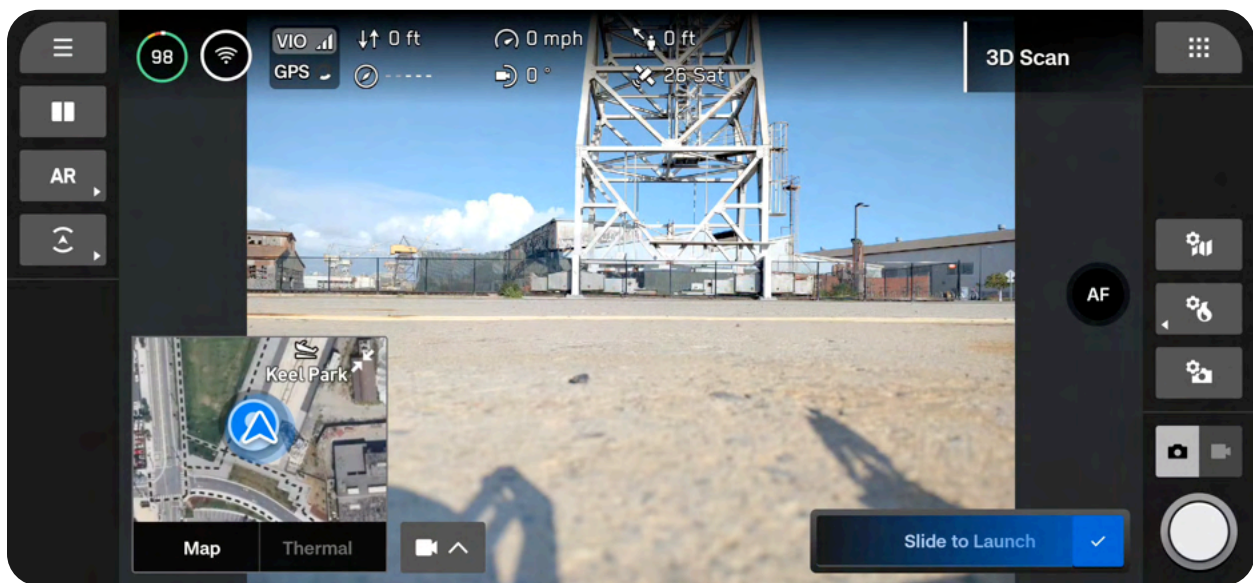
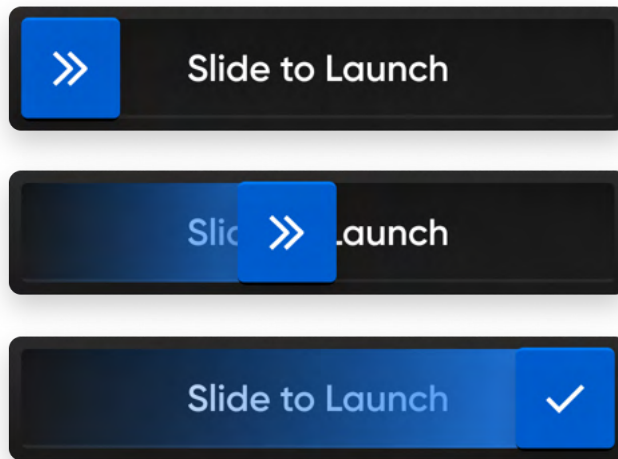

Step 4 - Return Behavior

Set your preferred return location. The drone will autonomously return to this location when the battery level is low or if the drone loses connection.

Use Launch Point - the drone will return to the launch location.

Set Custom Rally Point - manually pilot the drone to a new location and set this as your Rally Point. The drone will return to this location.

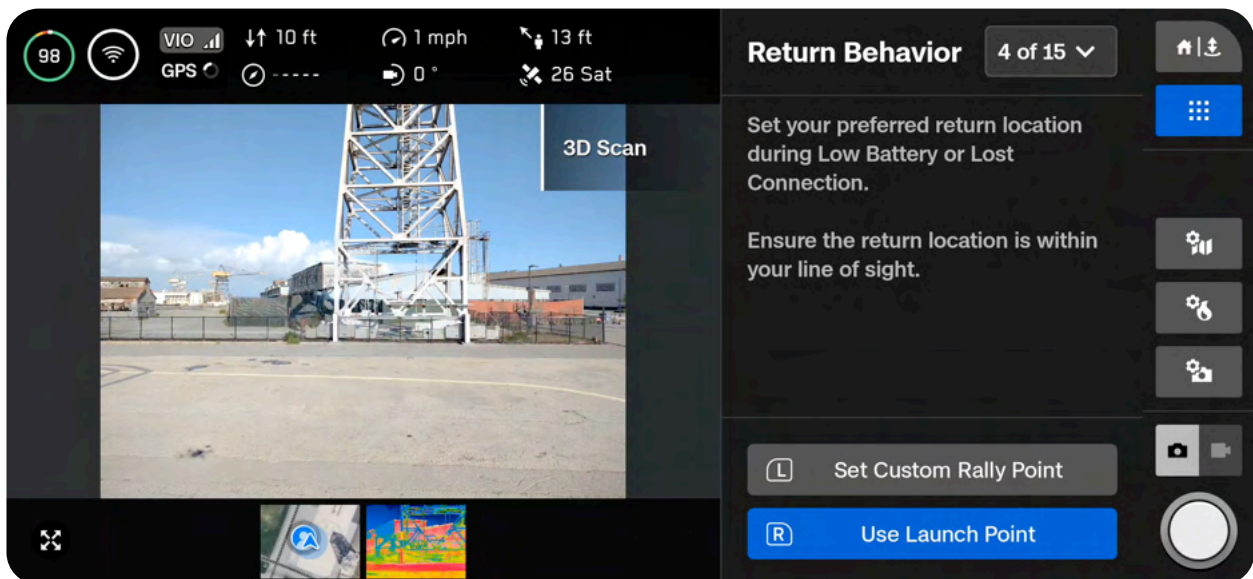

Tips for setting a Rally Point:

- *The Rally Point should be in your line of sight with a clear path to the Launch Point.*
- *Set your Rally Point close to the scan region so that the drone can safely and easily return to that point autonomously. Even if you change position during the scan, the drone will always have a point to return to safely without obstruction.*
- *Choose a location that is safe for landing.*

Step 5 - Floor

The Floor defines the bottom of the 3D volume you wish to scan. It will also define the bottom of your scan in the **Visual Geofence** and the **Model Viewer**.

There are two ways to begin setting the Floor:

Use Default Height starts the Floor at 1.6 ft (0.5 m) **above** the launch height. To ensure the ground is captured, Extend Volume > Below Floor is toggled on by default.

Set Custom Floor Height starts the Floor at the current height of the drone.

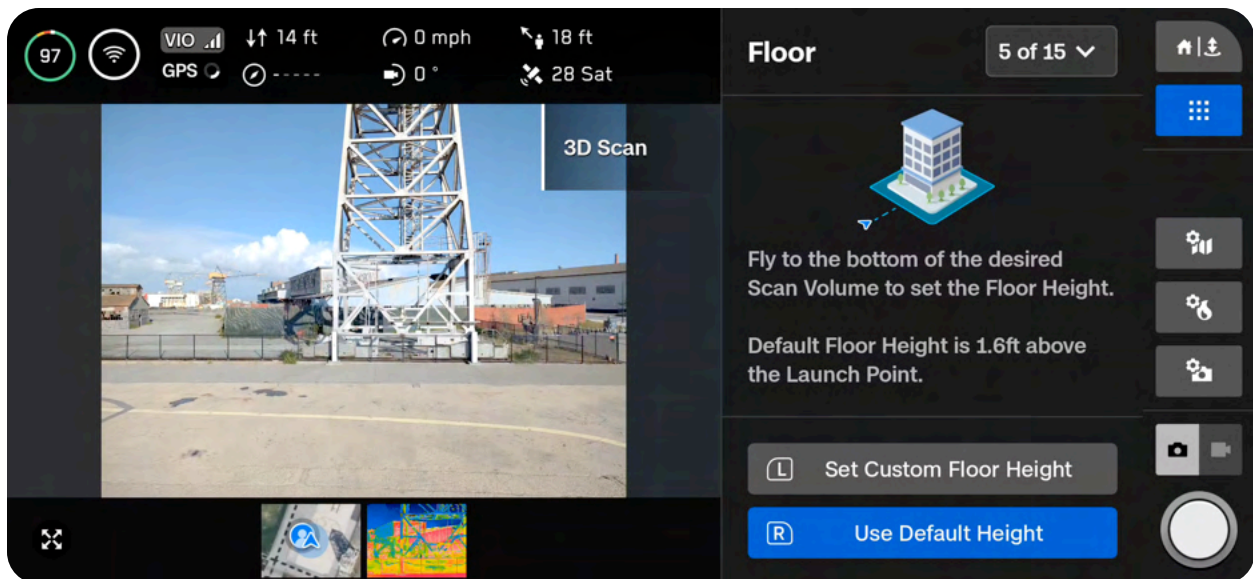

When setting a custom Floor, the Launch Height is represented by a light gray AR plane. Adjust as desired:

- **Pilot X10** and the Floor will automatically move with the drone as you fly
- **Drag** the orange Floor AR to the desired height
- **Done** – Sets the Floor in your desired location and proceeds to the next step
- **Center Floor** – Moves the location of the Floor to the current altitude of the drone
- **Level Gimbal** – Moves the camera gimbal pitch to 0°

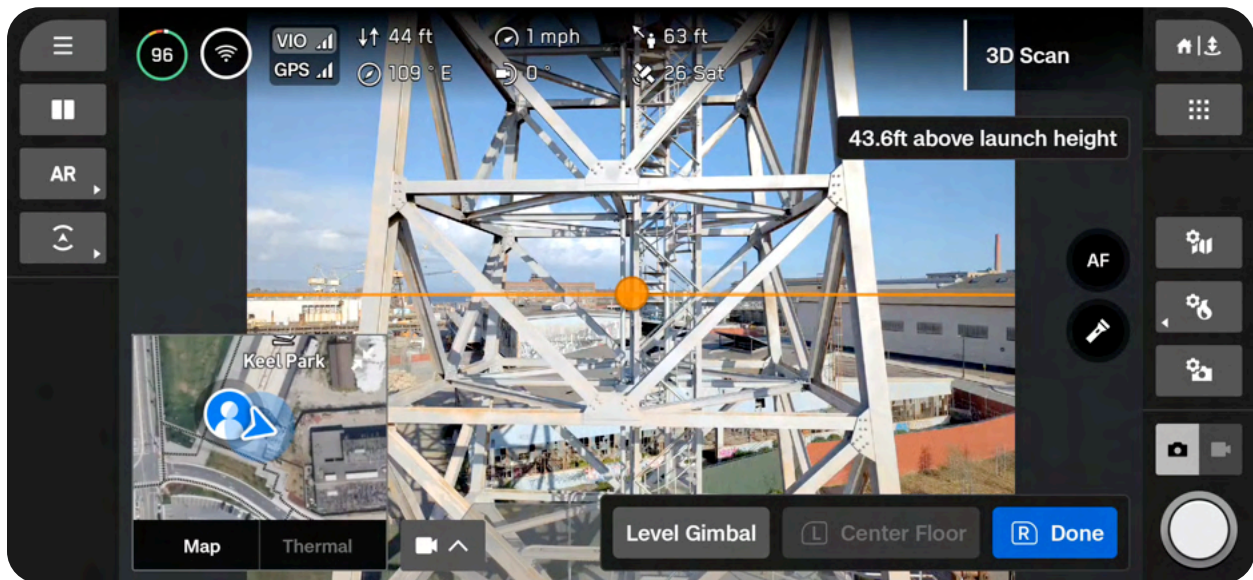

Step 6 - Ceiling

The Ceiling defines the top of the 3D volume you wish to scan. It will also define the top of your scan in the **Visual Geofence** and the **Model Viewer**. The Ceiling needs to be set above both the Floor and the structure you are scanning.

Once selected, adjust the Ceiling as desired:

- **Pilot X10** and the Ceiling will automatically move with the drone as you fly
- **Drag** the green Ceiling AR to the desired height
- **Done** – Sets the Ceiling in your desired location and proceeds to the next step
- **Center Ceiling** – Moves the location of the Ceiling to the current altitude of the drone
- **Level Gimbal** – Moves the camera gimbal pitch to 0°

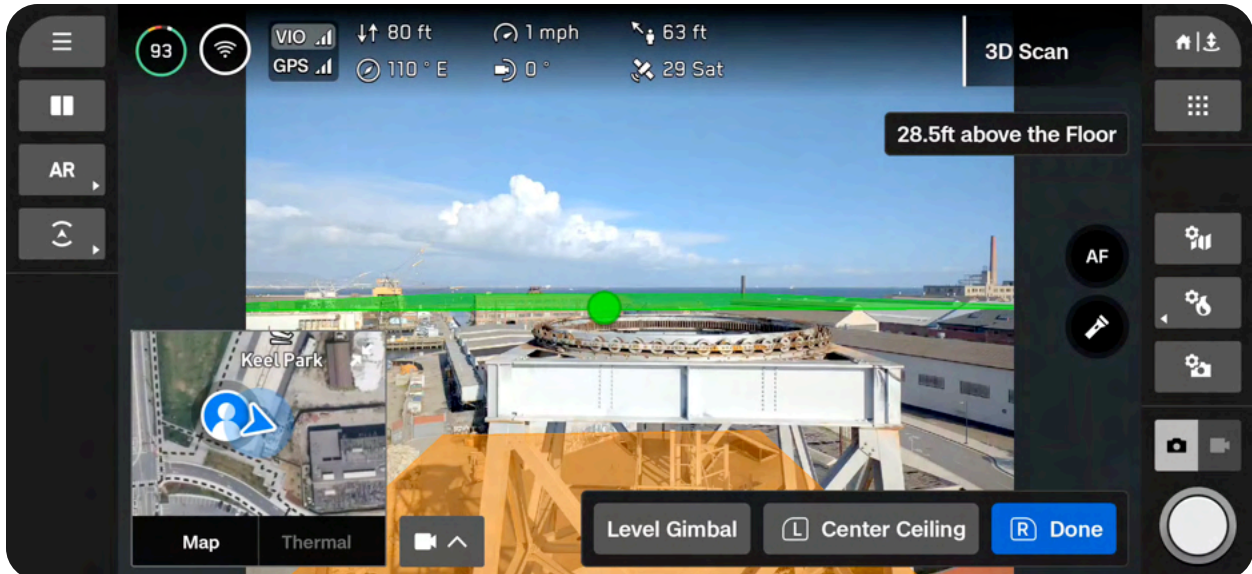
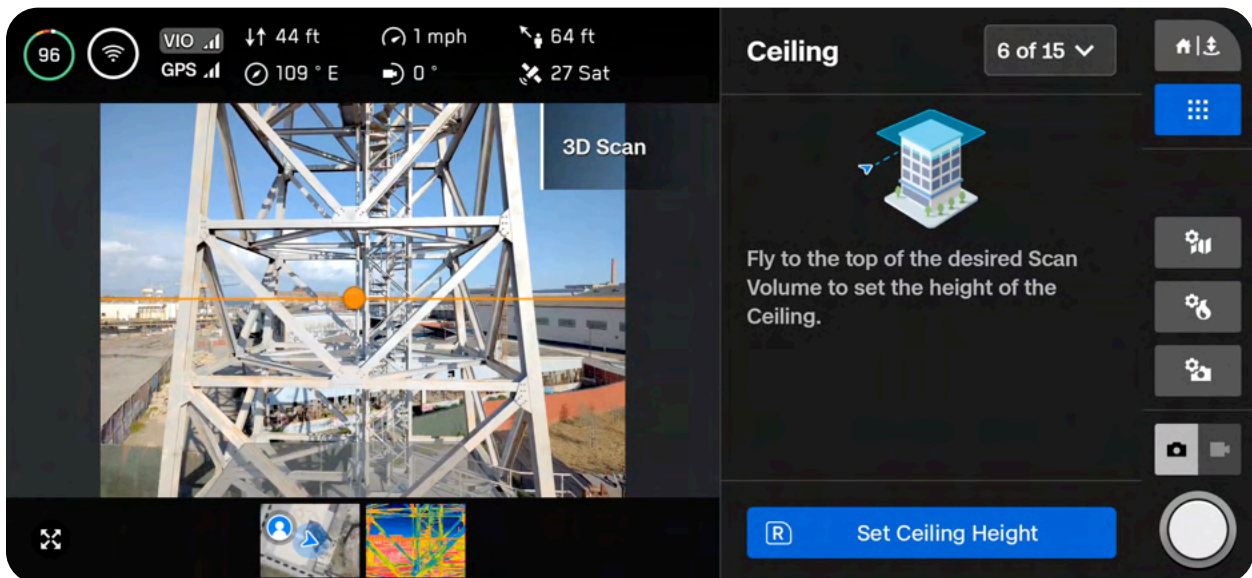

Step 7 - Boundaries

Set pillars to encompass the structure to be scanned. These pillars define the lateral bounds, or walls, of the **Visual Geofence**. It will also define the lateral area of your model in the **Model Viewer**.

A minimum of three pillars must be set to create a 3D volume.

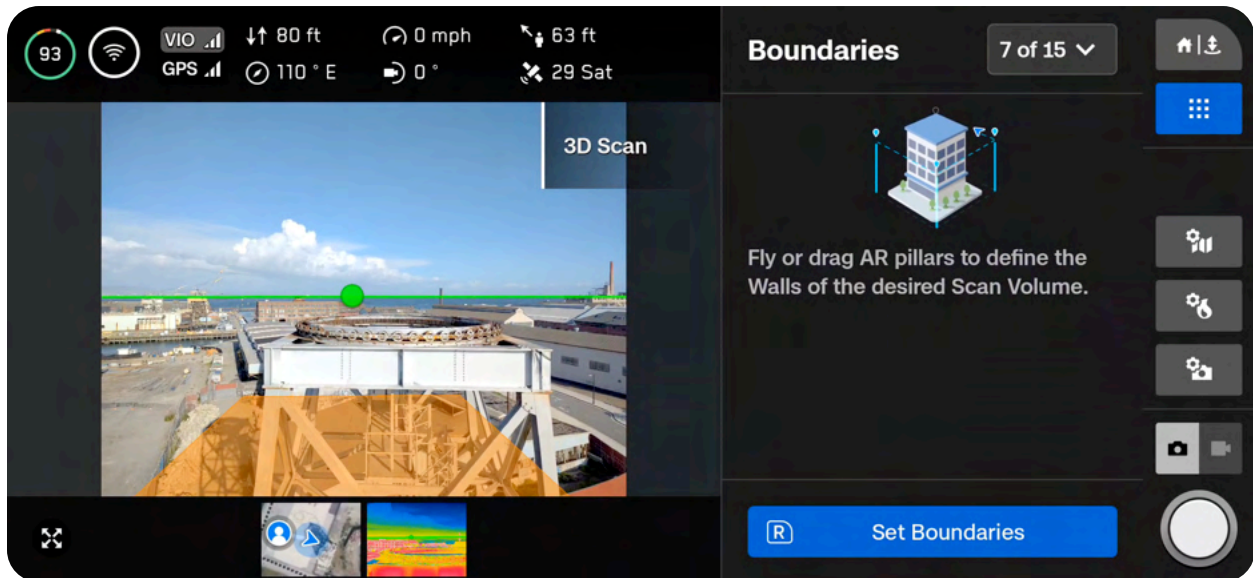

There are two options when setting pillars:

Fly to the desired location and use the right shoulder button to select **Set Pillar**. Continue placing pillars to encompass the entire structure. By default, pillars are attached to the drone. The edges of the polygon defined by the pillars must not cross each other.

- **Set pillar** – Adds a new bounding pillar
- **Remove** – Removes the previous bounding pillar
- **Done** – Completes this step and finalizes pillar placement



TIP: Try adjusting the angle of the gimbal for a better view of where you are placing pillars.

Drag pillars by holding the base of the yellow AR Pillar on-screen. This selects the active pillar and enables dragging. You may continue to set pillars by dragging or reconnecting the pillar to the drone by selecting “Attach.”

- **Set pillar** – Adds a new bounding pillar
- **Remove** – Removes the previous bounding pillar
- **Attach** – Reconnects the pillar to the drone
- **Done** – Completes this step and finalizes pillar placement



INFO: Only the current active pillar may be dragged.

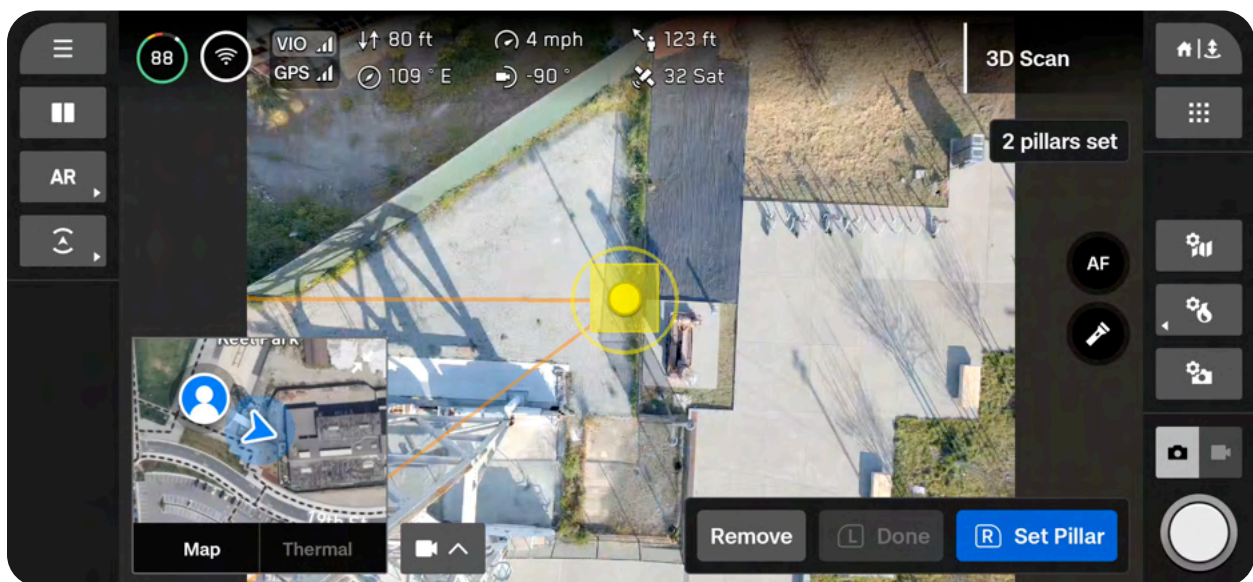

Step 8 - Extend Volume (optional)

This optional step allows you to extend the scan volume beyond the Floor, Ceiling, or Walls to capture surfaces outside the boundaries.

Select **Edit Volume** to extend your capture area. **Below Floor** is enabled by default to ensure the ground is captured.

If a **Strict Geofence** is enabled, the drone will capture photos of surfaces located outside of the scan volume without physically flying there. For example, if you enable **Strict Walls**, the drone will not fly outside of that boundary.

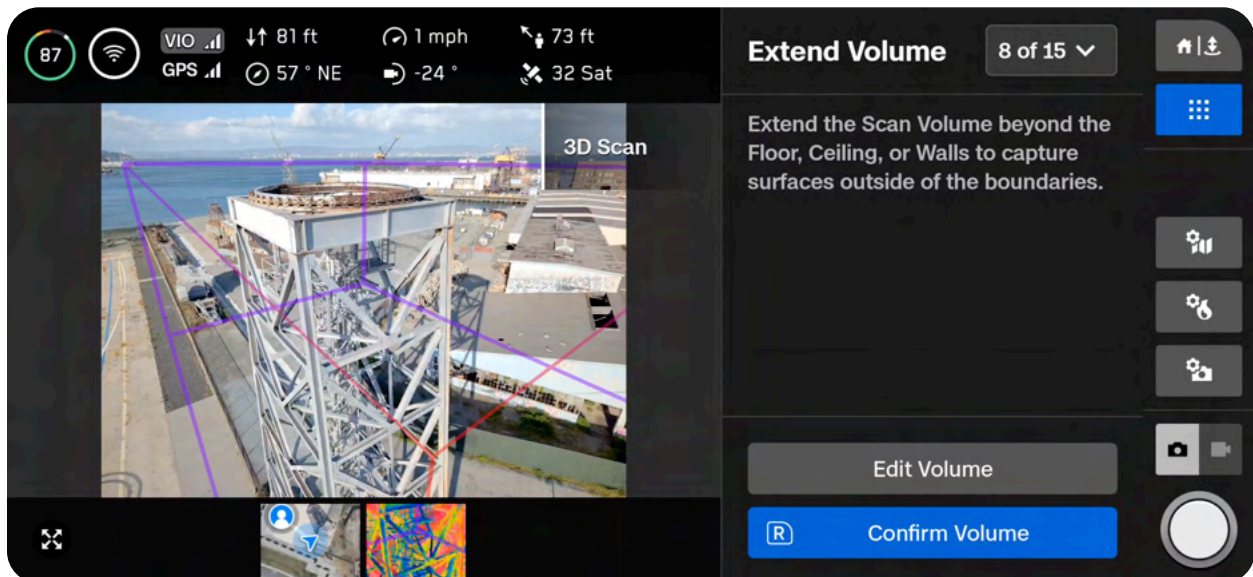

Use the adjustable distance slider to set the distance at which Skydio will capture photos outside of the scan volume.

EXAMPLE: If you set the distance slider to 8 feet (2 meters), enabling one of the extended volumes allows you to capture photos 8 feet (2 meters) outside of the scan volume.

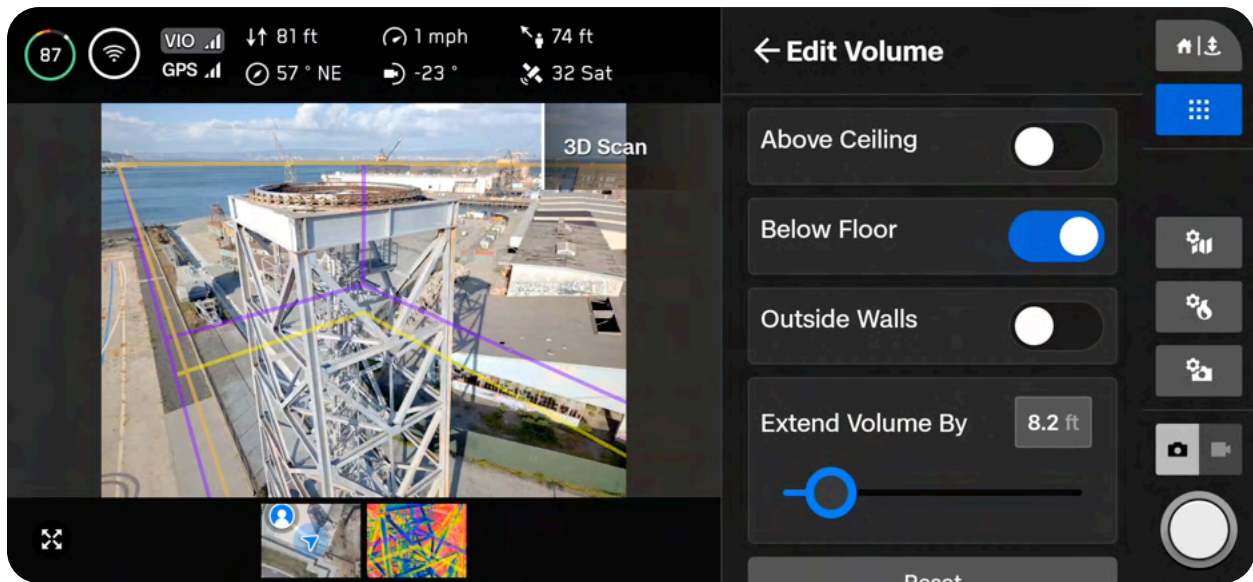

CAUTION: The “Extend Volume By” distance should not be larger than your Distance to Surface (DtS). If this happens and a strict geofence is enabled, no photos will be captured of objects in the extended capture area.

Step 9 - Strict Geofence

Independently toggle the Ceiling, Floor, and Walls **ON** or **OFF** to set the geofence. By default, Skydio will remain within the scan distance of the boundaries.

Enabling a strict geofence (selecting **ON**) blocks flight outside of the scan volume along that bound. The drone will continue to enter and exit the scan volume through the same location.

- Skydio honors the Visual Geofence during the Explore phase and the scanning process, as well as when transitioning between the two. *Read more about the Visual Geofence in the 3D Capture Settings section.*
- You will also see a setting called **Safe Distance**, which allows you to set the distance from which Skydio will stay away from the structure while scanning. *Read more about this setting in the Visual Geofence or the 3D Capture Settings sections.*

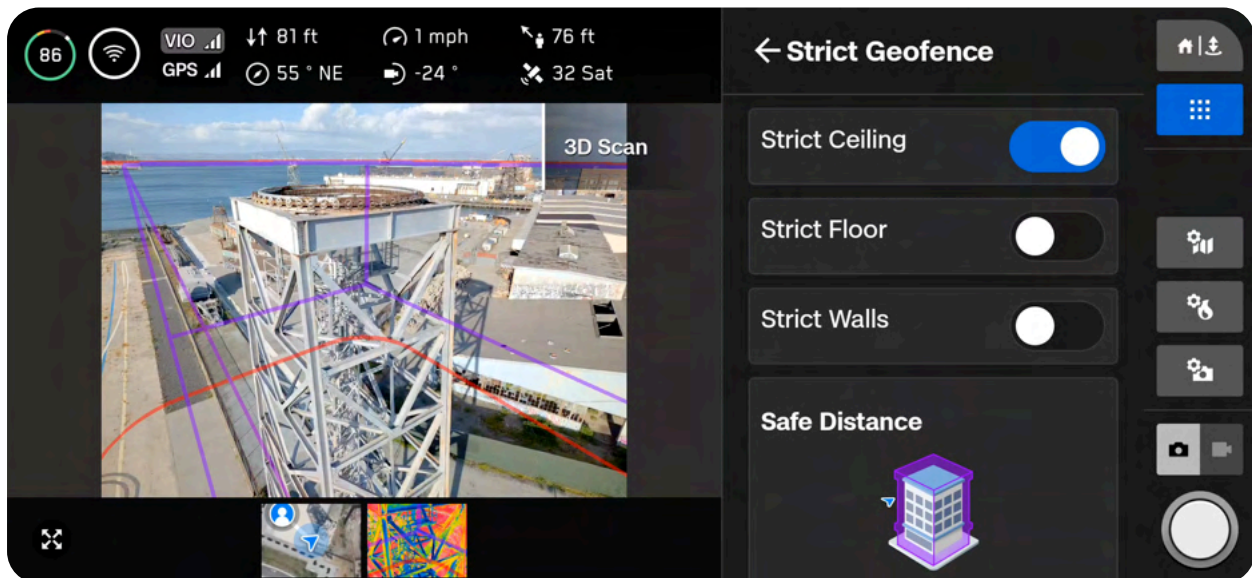

NOTE: Skydio will skip image capture locations that are located outside any of the toggled geofence boundaries. This may result in gaps in coverage.

Step 10 - Set AR Observer

The Augmented Reality (AR) Observer allows you to set the point of view from which you can observe an augmented-reality view of the scan progress.

- When you set your AR Observer point, the drone will take a static image from that position
- The AR drone will follow the white lines, which denote the planned flight path and image capture locations
- The purple AR lines show the Wall boundaries (pillars)

There are two options when setting the AR Observer:

Review Suggestion means Skydio will fly to the ceiling of the pillar closest to the launch position. The drone will then face the structure (the centroid of the AR polygon-prism).

Set Custom AR Observer allows you to manually pilot the drone to your preferred vantage point. If you choose to manually set the location of the AR Observer, ensure you are choosing a spot that provides you with the best situational awareness for monitoring the scan's progress.

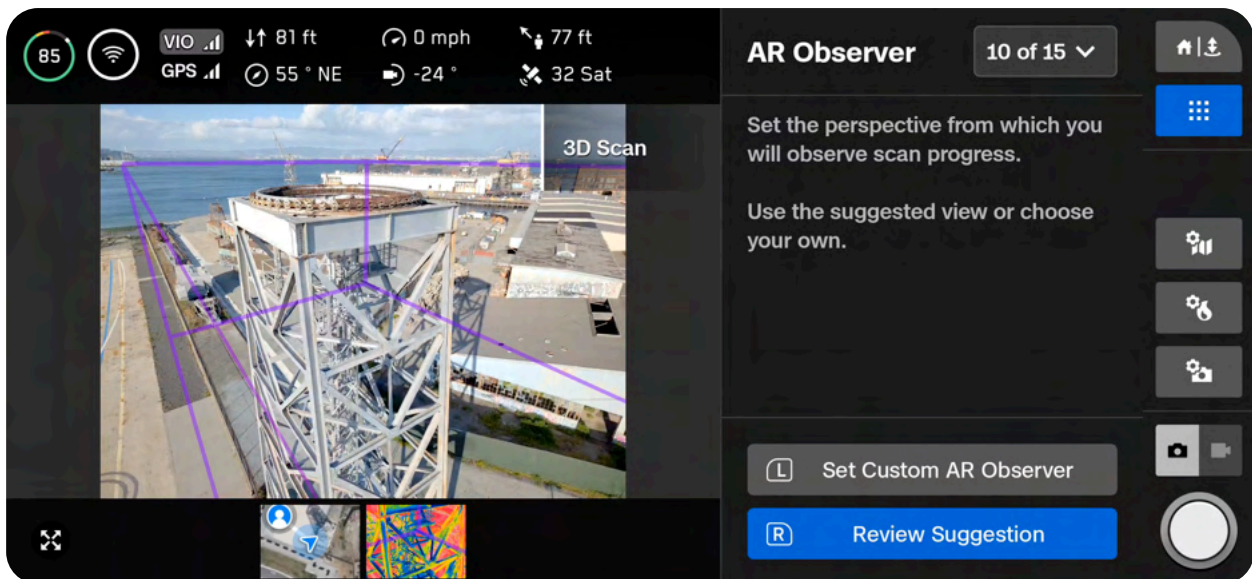

NOTE: The AR Observer is only available for the color camera.

**Tips for manually setting the AR Observer:**

- Tightly frame the structure and fill the frame vertically or horizontally
- Select this option if you are scanning around obstacles or in complex environments

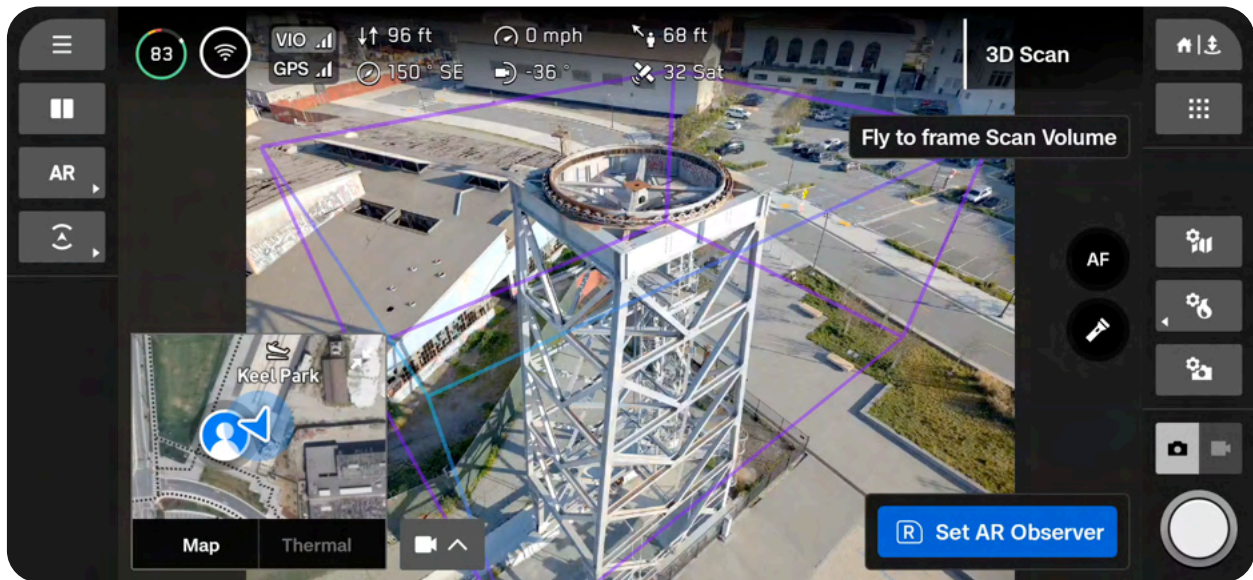

To view the AR Observer, select the **Picture-in-Picture (PIP)** button in the bottom left of the Flight Screen. You also have the option to set this as one of your views in the Single, Split, or Grid Display Layouts.

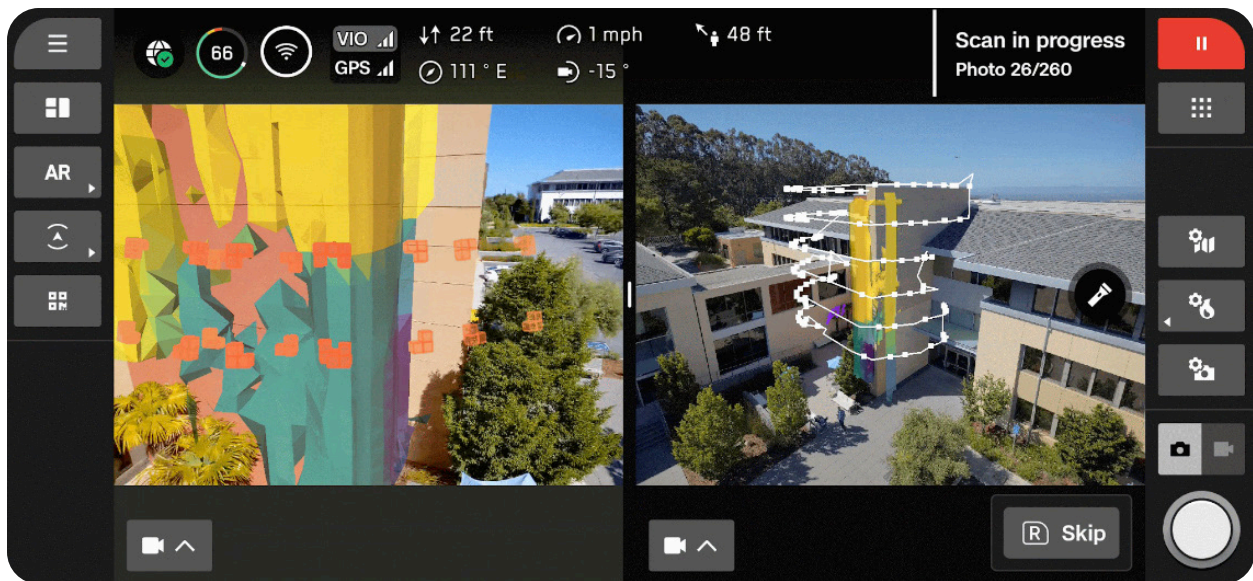
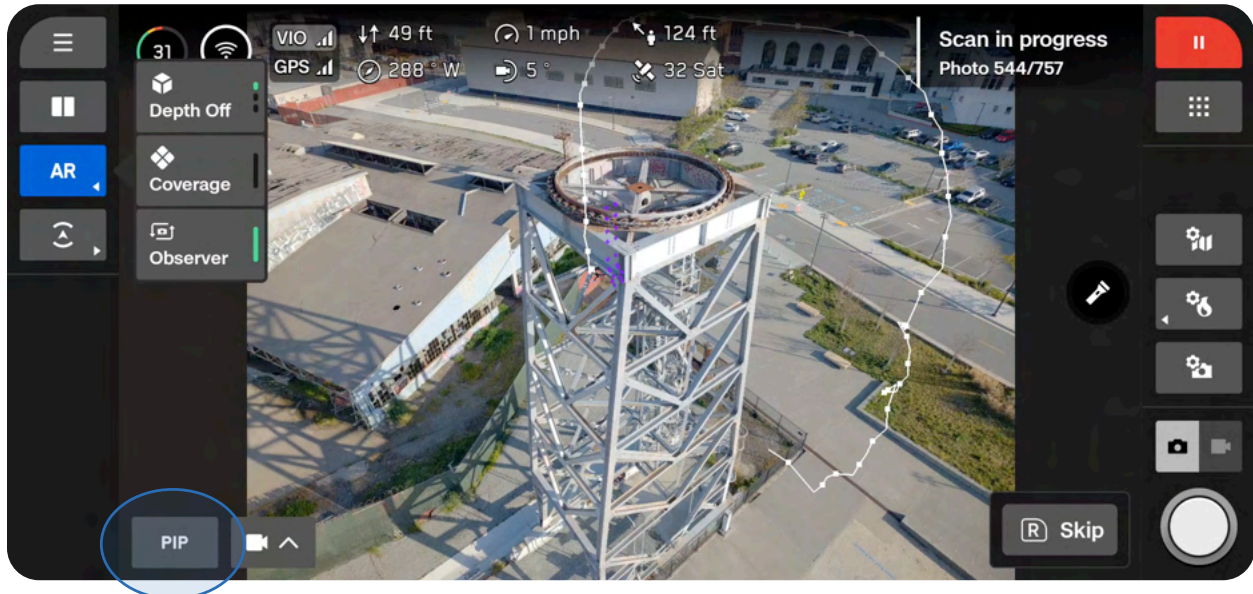

Step 11 - Exploration

The drone will briskly and autonomously fly around the scan volume to build an internal model of the structure being scanned.

Select **Edit Settings** to adjust the speed at which your drone completes the Explore Phase.

- Minimum speed: 1.1 mph (0.5 m/s)
- Maximum speed: 11.2 mph (5 m/s)
- Default speed: 5.6 mph (2.5 m/s)

You may also enable a **Strict Geofence** for this exploration phase.

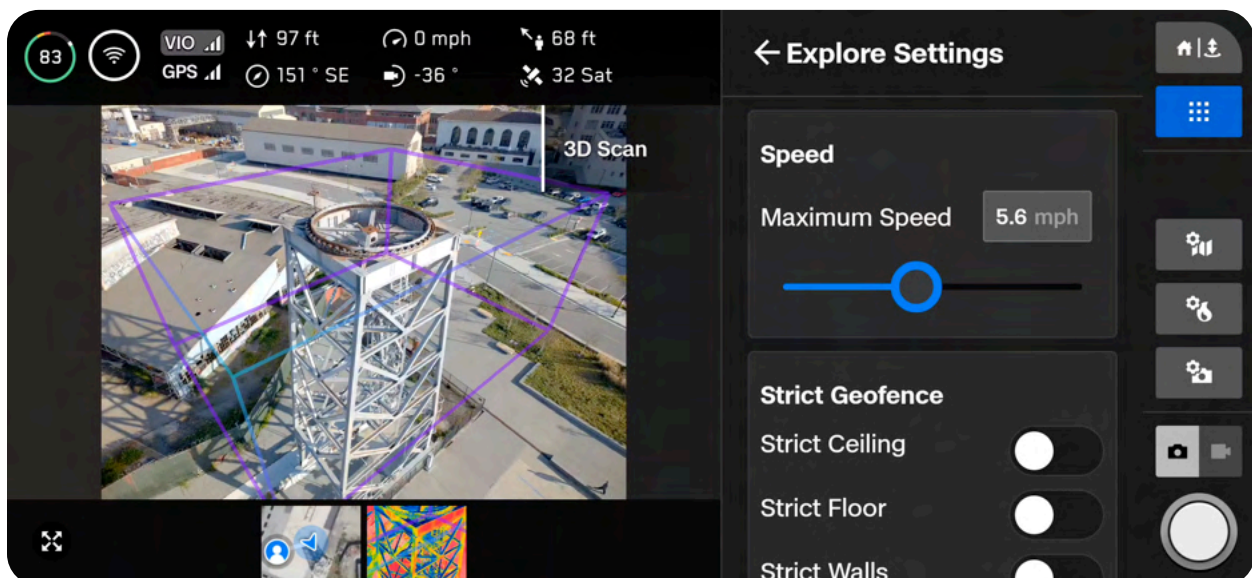
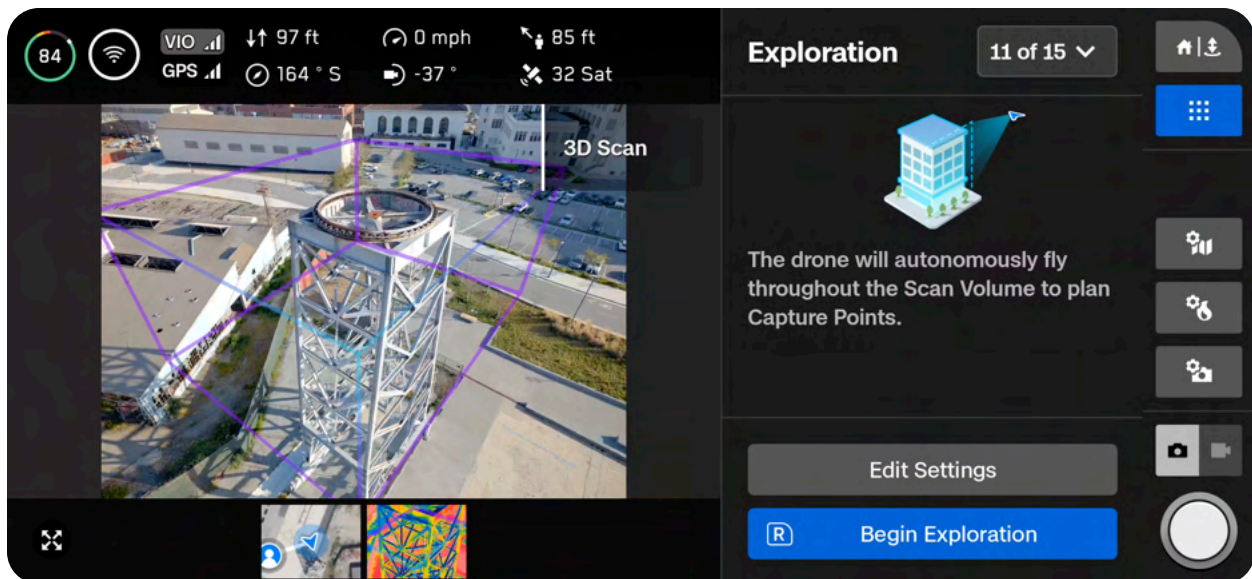

Skydio uses this internal model to intelligently predict overall scan time and number of capture points needed to complete the scan. The explore phase should be a small fraction of the total scan time, and a rough time estimate is given.

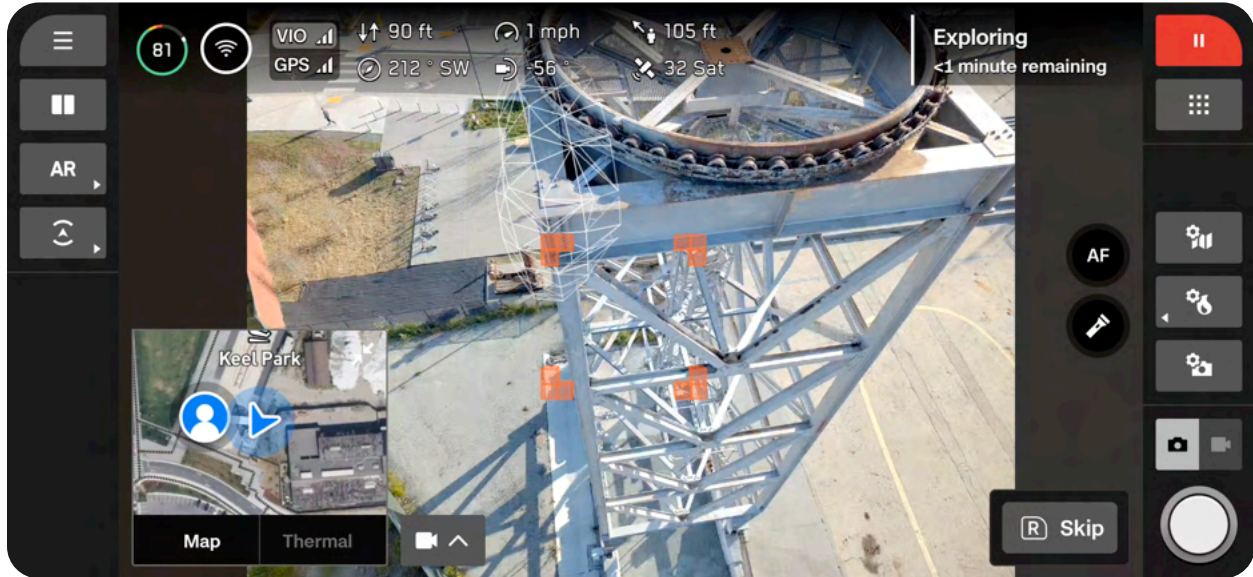

CAUTION: Ensure you have enough battery to complete the Exploration step and begin scanning. You will only be able to save the progress of a scan once scanning begins. If your battery dies before scanning begins, you will need to restart the scan setup after replacing the battery.

Step 12 - Scan Settings

View a summary of your scan settings, plus estimates for the total scan time, required number of batteries, and total number of photos. You must have at least five photos to begin a scan. Editing scan settings will impact the total flight time, number of photos and the required number of batteries.

Scan settings include:

- Distance to Surface
- Overlap and Sidelap
- Strict Geofence
- Safe Distance
- Maximum Speed
- Scan Passes (Z, Y, X)
- Maximum Speed
- Take Best Photo
- Stop for Photo
- Photo Settings (located in a separate menu)
- Field of View (VT300-L only)

Settings persist across scans of the same scan mode. Select the Reset button at the bottom of the list to restore settings to defaults.

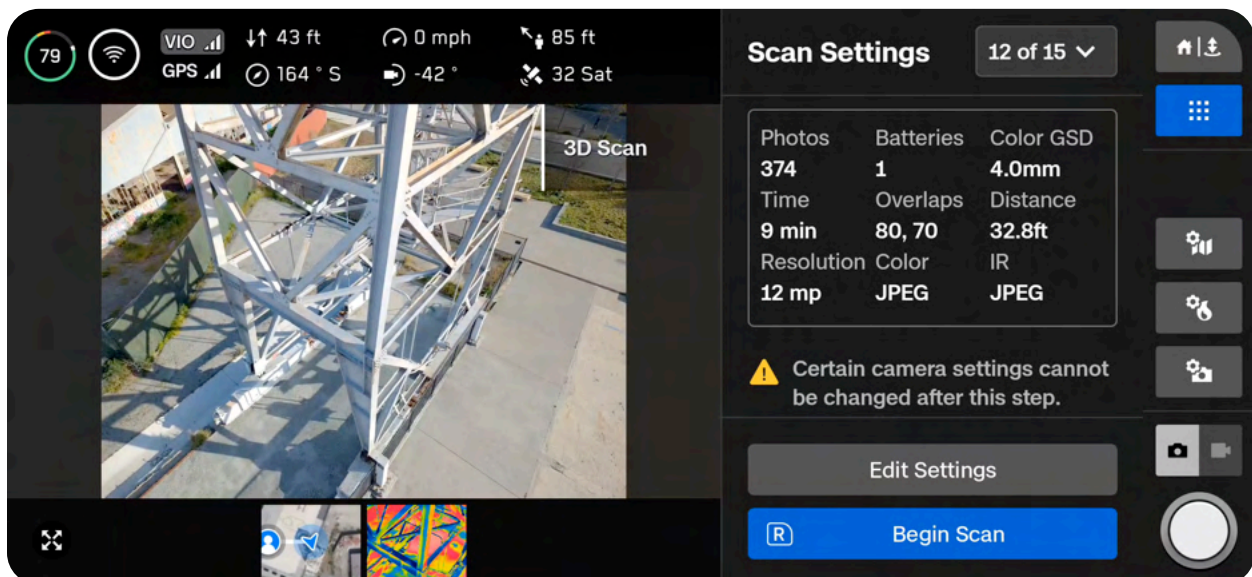

The thermal camera has a different Field of View (FOV) compared to the color (RGB) camera. Due to this, the **Overlap, Sidelap, and GSD (Distance to Surface slider)** values for the thermal camera and the color camera are different within the same scan. The values in the workflow pane on the right represent the color camera settings.

- You will see a summary of the thermal (IR) setting values displayed on the bottom of the live camera feed

If you are conducting a thermal scan and want a higher Overlap/Sidelap or GSD, increase these settings in the workflow pane until you reach your desired values.

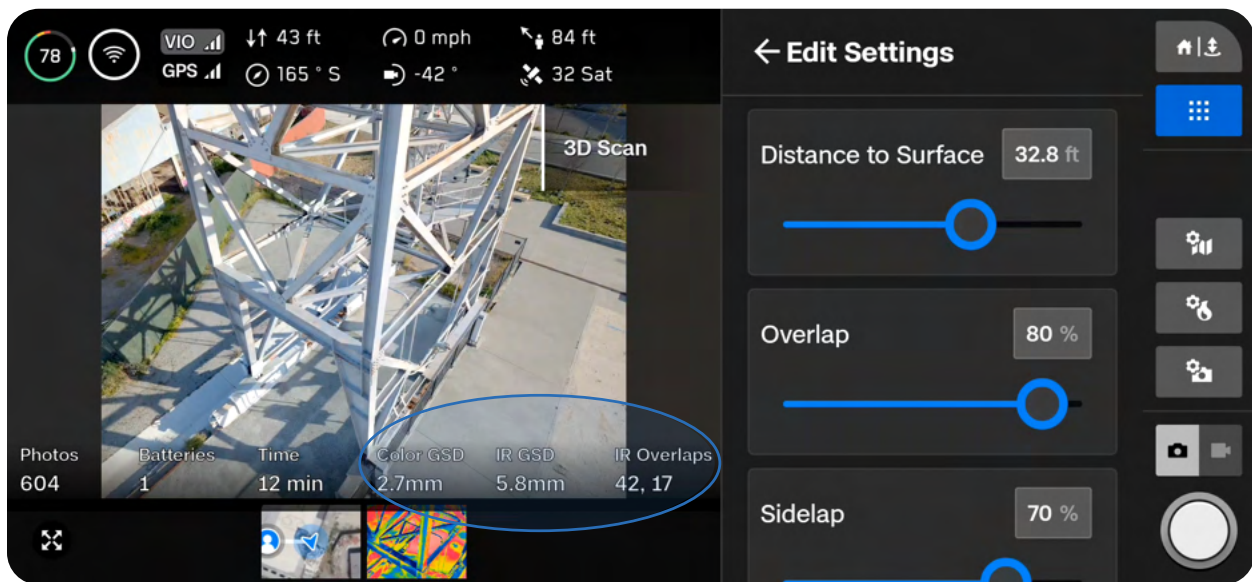

When reconstructing a thermal-only scan, we recommend at least 80/80 Overlap/Sidelap for the thermal sensor.

Intended thermal (IR) Overlap/Sidelap	Corresponding Color Overlap/Sidelap (Wide camera)	Corresponding Color Overlap/Sidelap (Narrow camera)
85/85	95/95	90/90
80/80	93/93	88/88
70/70	90/90	85/85

Photo Settings

You can also adjust your camera settings, including color and thermal camera settings, at this stage. Select the **Color or Thermal camera icons** on the right side of your screen to access your photo settings.

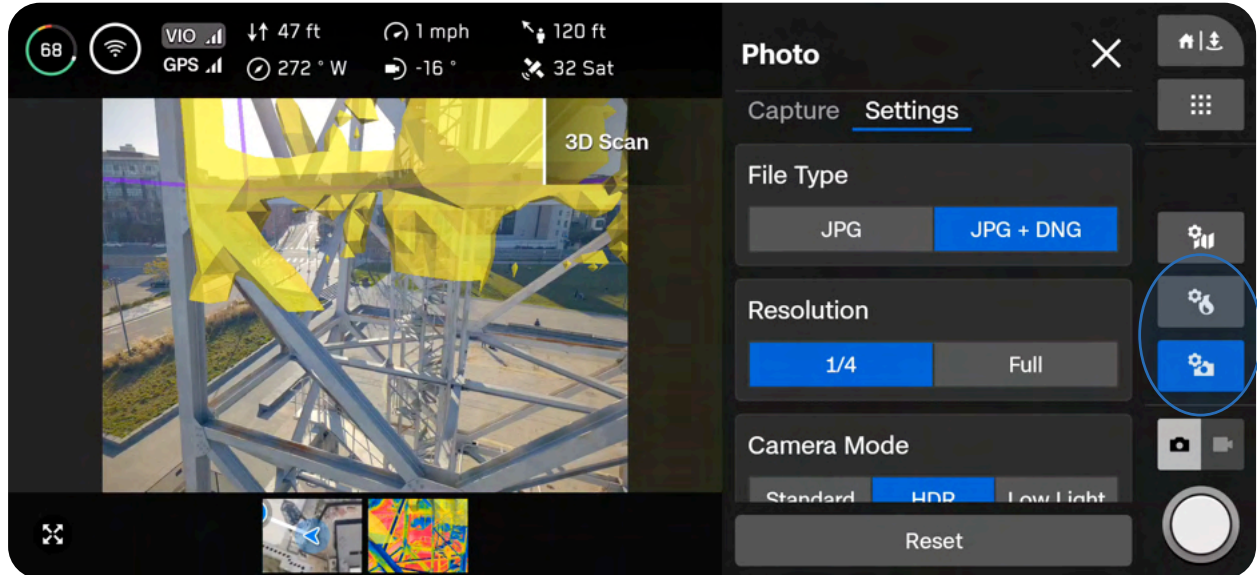

After this step, you will not be able to adjust the following camera settings while scanning:

- Resolution (Full or 1/4)
- Camera Mode (Standard, HDR, Low Light)
- Enabling or disabling thermal JPG or RJPG files
- Enabling or disabling DNG files
- Changing Field of View: Wide vs Narrow (VT300-L only)

If you plan to process your thermal images in an external tool, you must enable RJPG files. Navigate to Thermal Camera > Settings and toggle on RJPG. This will ensure your drone captures radiometric JPG files.

You cannot capture thermal images by themselves. The following two file combinations are available:

- RGB files and Thermal JPG files
- RGB files and Thermal JPG + RJPG files
- If RJPG is enabled, you will also capture thermal JPG

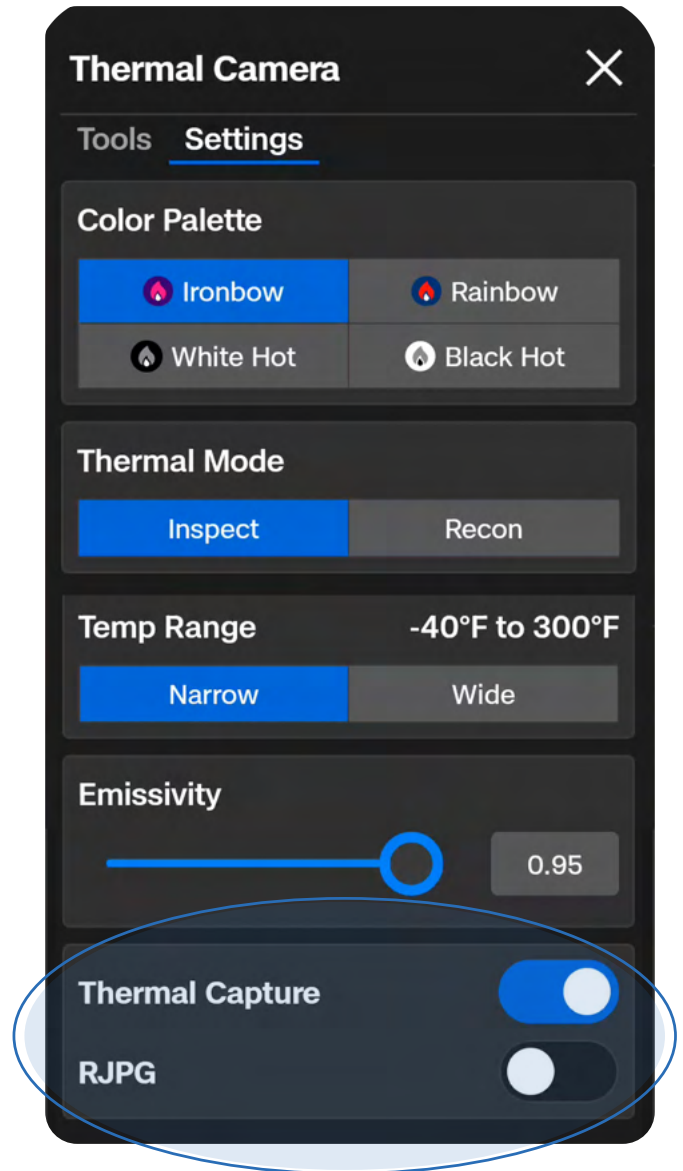

Once your settings are finalized, you may select **Begin Scan** and Skydio will begin autonomously scanning the structure.

Step 13 - Scan

You will see AR markers showing the scan capture points on the live camera feed.



Optionally toggle on the AR Coverage Mesh during your scan to monitor the photo coverage progress of the scan. *Learn more about this feature in the AR Coverage Mesh section.*



Pause at any point during your scan. Use the left shoulder button or tap this icon in the workflow pane to pause scanning. Skydio will display how many photos have been captured. While paused, you have the option to manually capture photos using the right shoulder button.



Press the play icon or use the left shoulder button to resume autonomous scanning. Use the right shoulder button during a scan to Skip to the next capture point.

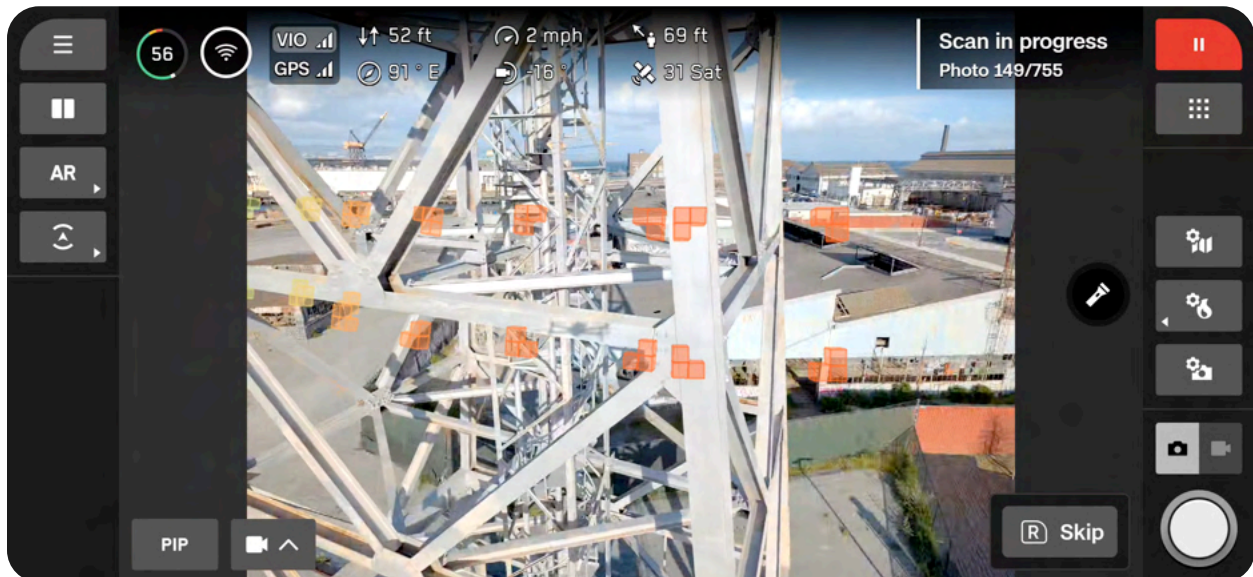

Your scan may require using several batteries to complete. *For information about how to scan with multiple batteries, read the [Scanning with Multiple Batteries](#) section.*



NOTE: *Even if Stop for Photo is disabled, you may see the drone pause, along with a “Saving Photos” notification. This is to ensure the SD card finishes writing the data. Autonomous scanning will resume automatically.*

Step 14 - Manual Photos (optional)

Once your scan completes, you have the option to manually capture additional photos of the scene or specific areas of interest.

The purple AR outline on-screen shows the Wall Bounds. Use the right shoulder button to take a photo.

- Manual photos appear in the scan folder and in the Model Viewer alongside photos captured autonomously

Obstacle Avoidance is set to Standard—and cannot be changed—when Skydio flies autonomously.

- If you are manually piloting the drone, you have the option to adjust your obstacle avoidance setting in the Quick Actions menu

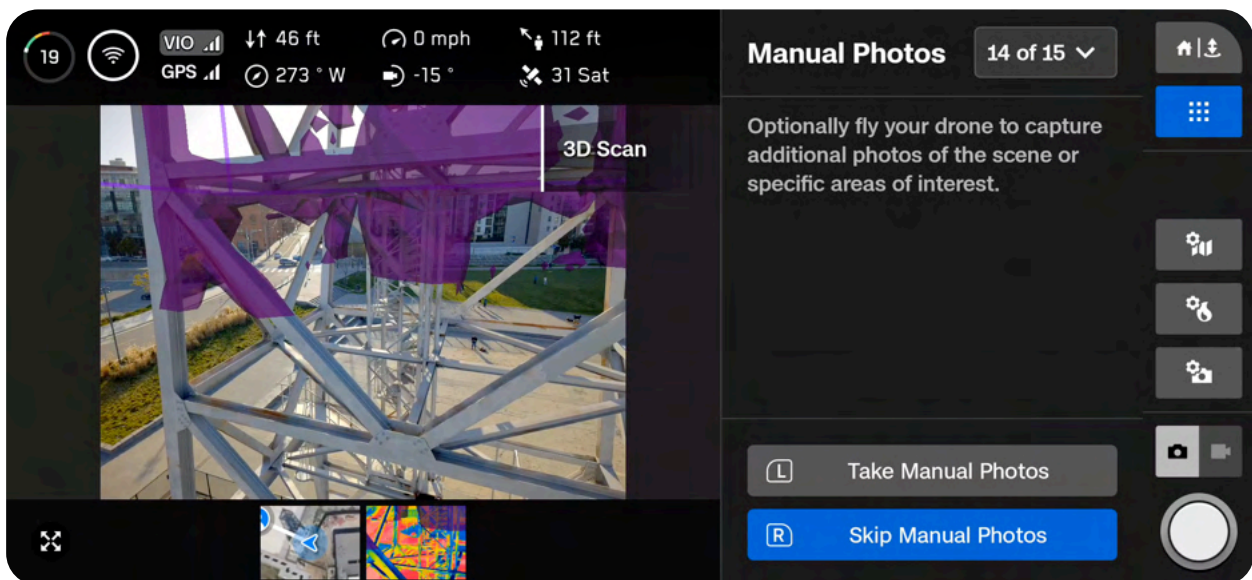

NOTE: Manual photos may be captured at any time by pressing pause. You may also optionally enable interval mode to have the drone take photos at different time intervals (ex: capture a photo every 5 seconds).



CAUTION: Skydio obstacle avoidance does not detect moving objects and is disabled during landing. Review the [Skydio Safety and Operating Guide](#) for more information.

Step 15 - Scan Complete

Once your scan completes, you have the option to either start a **New Scan** or **Return to Launch/Rally Point**.

Starting a new scan will prompt you with an option to save or discard the scan you just completed.

- If you Return to Launch and the path is clear, X10 will obey the geofence and fly in a straight path
- If X10 cannot find that path due to obstacles, you will be able to take control and manually pilot your drone

After landing, you will see a summary of the most recent scan and the option to **Save** or **Discard** the scan you completed.

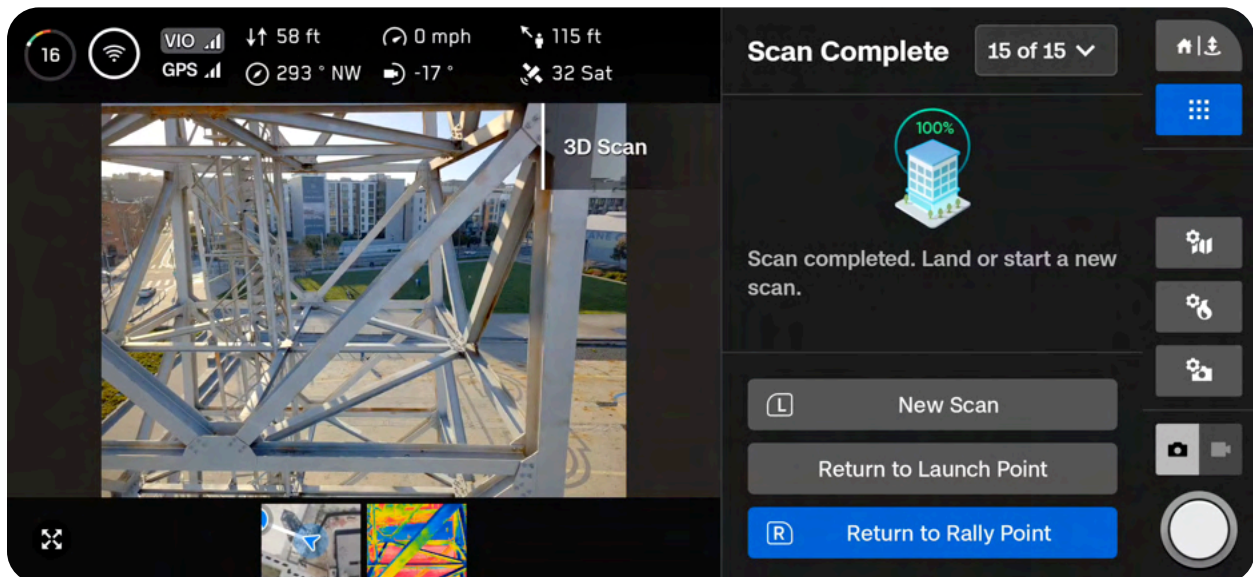

Step 16 - Post-processing

After saving your scan, you will have the option to create a textured model. This model is created onboard the drone and takes several minutes to complete.

If you select **No**, you will still need to wait a few minutes for the drone to process your scan. This is an important step to ensure your media is grouped by scan and saved properly.

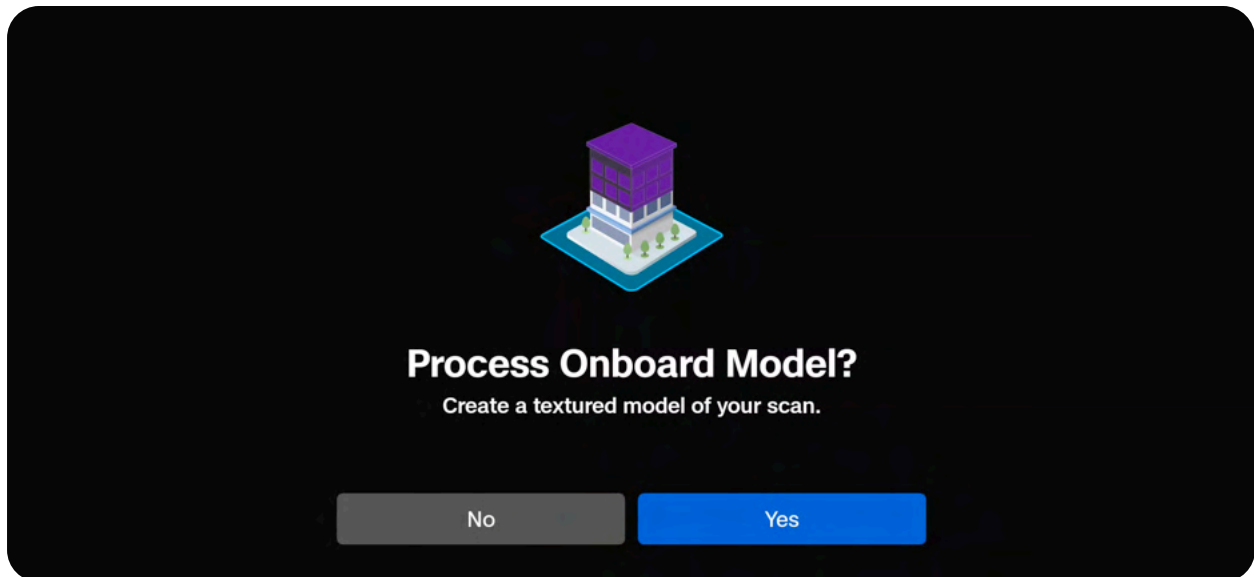

NOTE: If you do not generate an Onboard Model at this point, you will still have the option to generate one at a later time. For multi-battery scans, select **Yes** to generate an Onboard Model **after all flights are completed**.

If you select **Yes**, your drone will first process your scan and then the Onboard Model.

- Onboard Model creation uses HD thumbnails (1920x1440) and processes about 30 images per minute
- Model generation may take longer for larger scans (1000+ images)
- If the battery is low and you are processing a large model, ensure the drone is plugged into a power source

Once processing is complete select **Exit** to return to the Gate Screen or **Review Scan** to enter the Onboard Model Viewer.

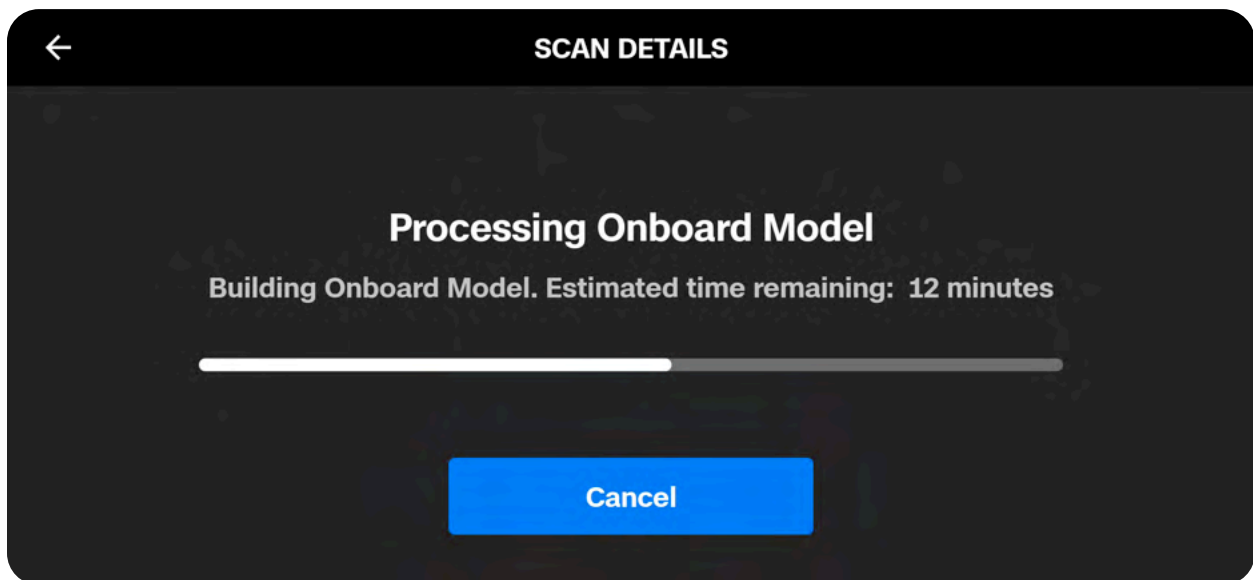

CAUTION: Do not remove the battery or power off during postflight processing. Doing so will result in loss of data. Do not power off or disconnect from the drone until processing is complete.

AR Coverage Mesh

The AR Coverage Mesh allows you to monitor the photo coverage progress of your scan. Select the **AR Quick Action** on the left sidebar of your Flight Screen, then select **Coverage** to display real-time AR photo coverage of your scan.

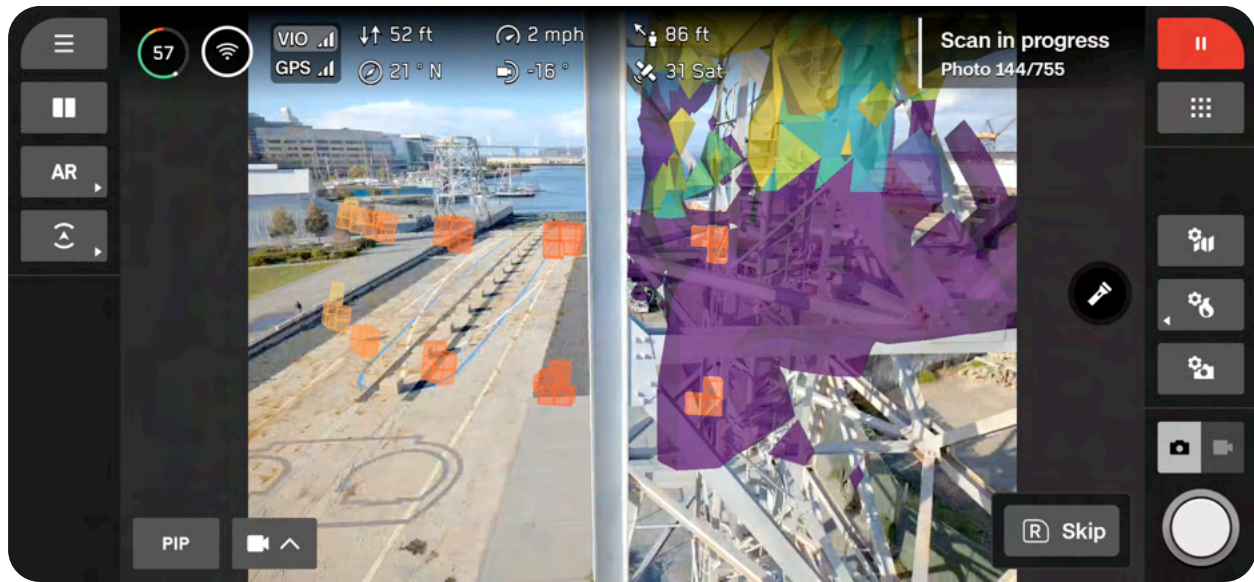

Ensure coverage of key areas and enabled the coverage mesh:

- During the Explore phase
- When reviewing scan settings
- Live while scanning
- When viewing the scan in the AR Observer
- During manual capture



NOTE: Images are not captured during the explore phase, but the coverage mesh will show the low-poly map building process.

Yellow indicates minimal coverage and purple indicates full coverage based on your chosen overlap settings.

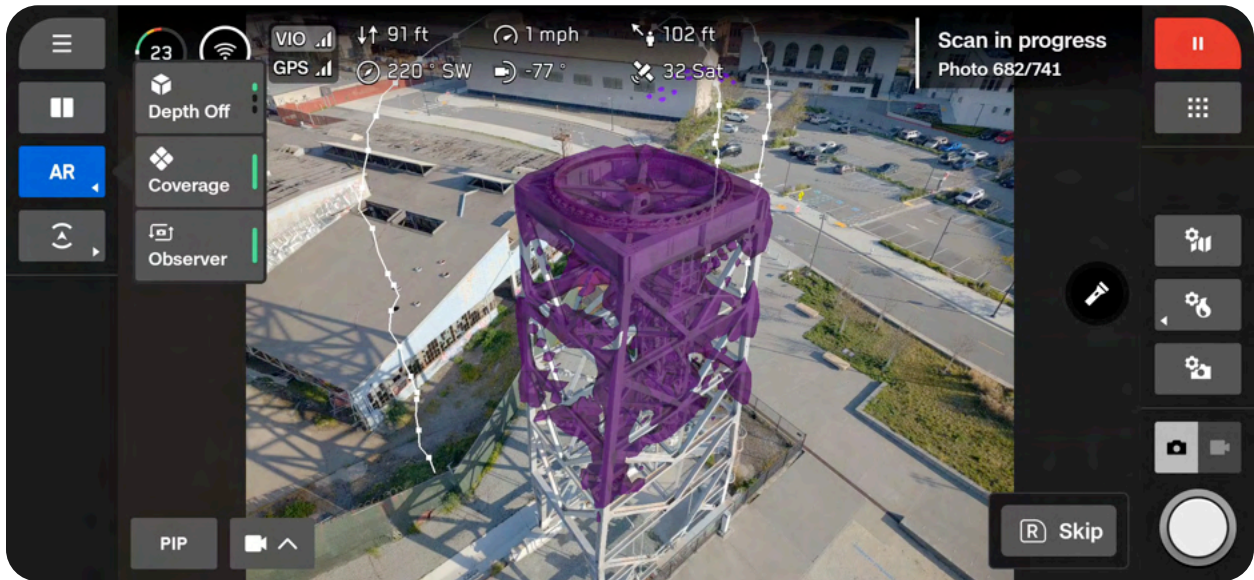

AR Coverage Mesh toggled ON

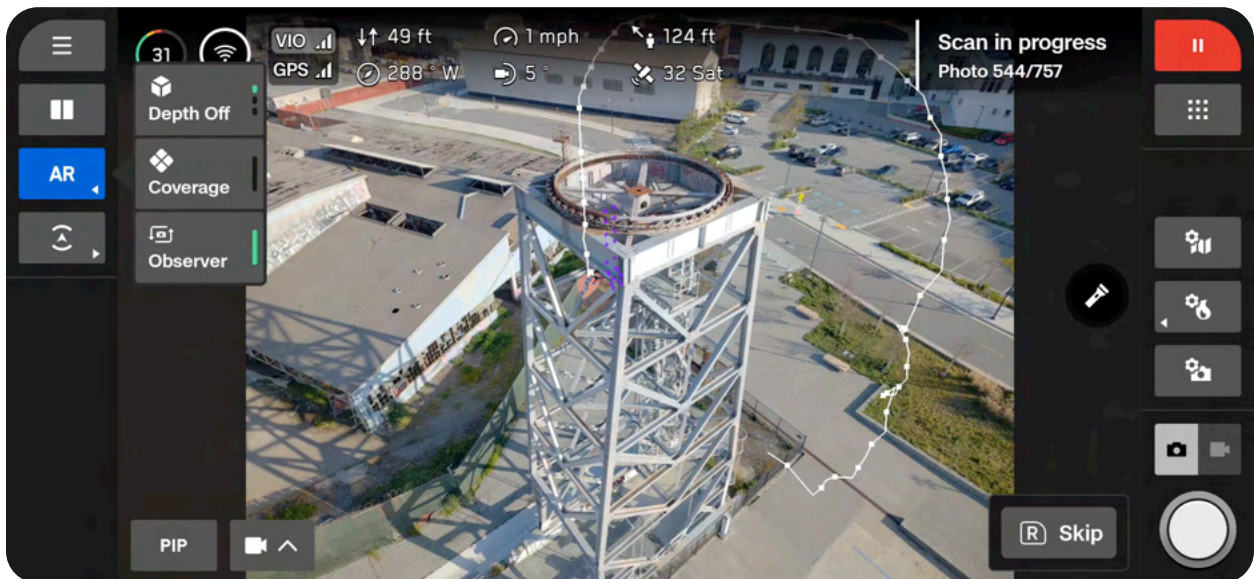

AR Coverage Mesh toggled OFF

Surface Capture Workflow

Overview

Before you fly:

- GPS will be required for scans higher than 65 ft (20 m).
- If needed, you can move backwards and re-do any steps in the workflow. Doing so will reset the steps you have already completed and discard any media that has been captured.
- If you are flying with a Skydio VT300-Z / VT300-L you have the ability to enable thermal image capture in the camera settings.

Refer to the table below for the default settings in this mode. For more detailed information about each setting, view the Surface Capture Settings section.

- Define the **Surface** and **Wall Boundaries** to create your **Area Boundary**

Setting	Default
Gimbal angle	0° Default Cross Hatch and/or Perimeter enabled: 60°
Overlap/Sidelap	70/70
Speed	5.6 mph (2.5 m/s)

Scan Setup

Step 1 - Scan Mode

Select **Surface Capture** as the Scan Mode. Tap **Select Scan Mode** on the screen or use the right shoulder button on the controller to confirm your selection.

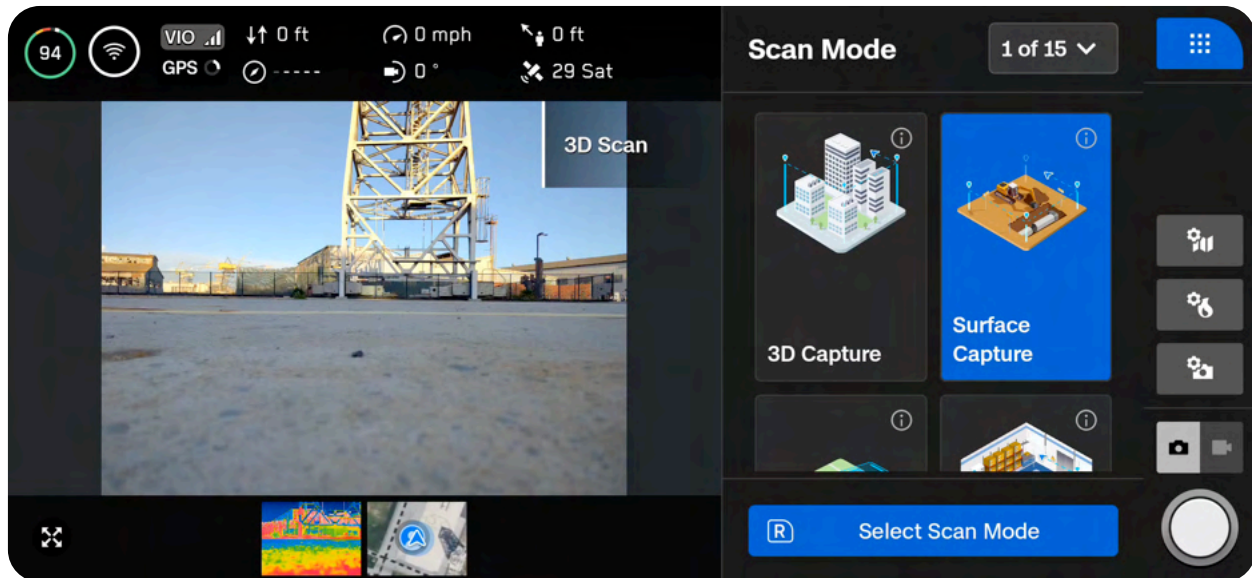

Step 2 - Scan Name (optional)

You may optionally rename your scan. The default scan name is composed of the scan mode you select followed by a UTC timestamp. Renaming the scan will replace the scan mode.

- Ex: Surface_Capture__2024-05-20T19-50-55.135854+00-00

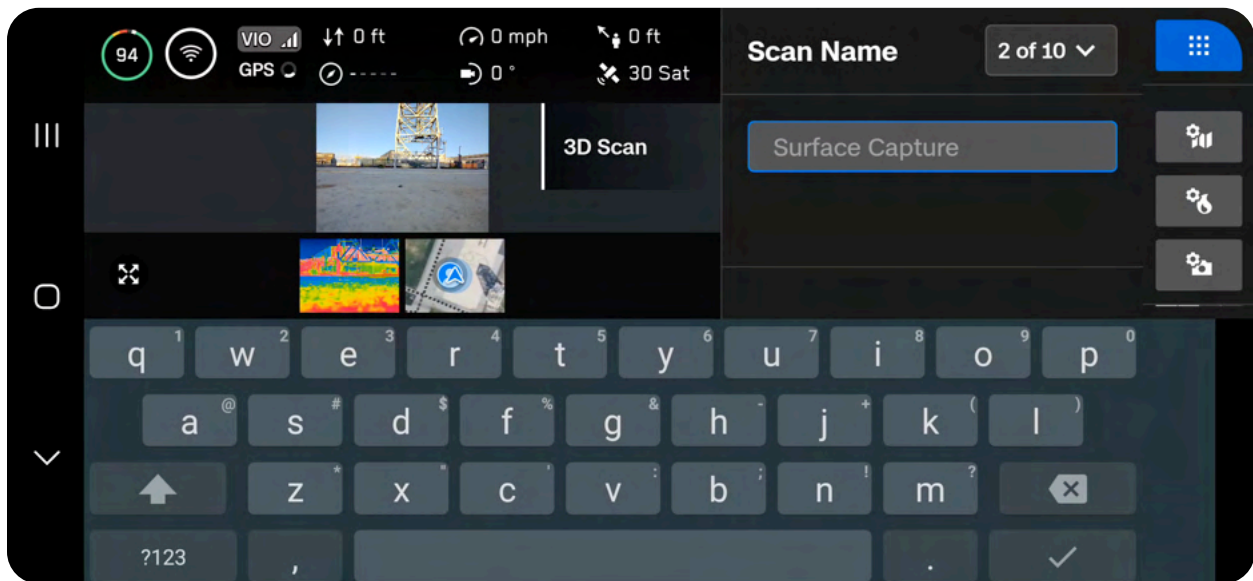

NOTE: Scan names must use American Standard Code for Information Interchange (ASCII) characters. You will be prevented from using unicode characters such as à, é, â, ü, ö, ä and the following symbols: < > : ; , \ | ? * & \$ { } ` “ Visit skydio.com/support for more information.

Step 3 - Launch

Drag the on-screen slider or press and hold the Launch/Land button on your controller to begin your flight. The drone will launch, automatically rotate 360 degrees, climb to 10 ft (3 m), and hover.

Take note of your launch orientation. If your scan requires multiple batteries, you will need to place the drone in the exact same location and orientation after replacing a battery.

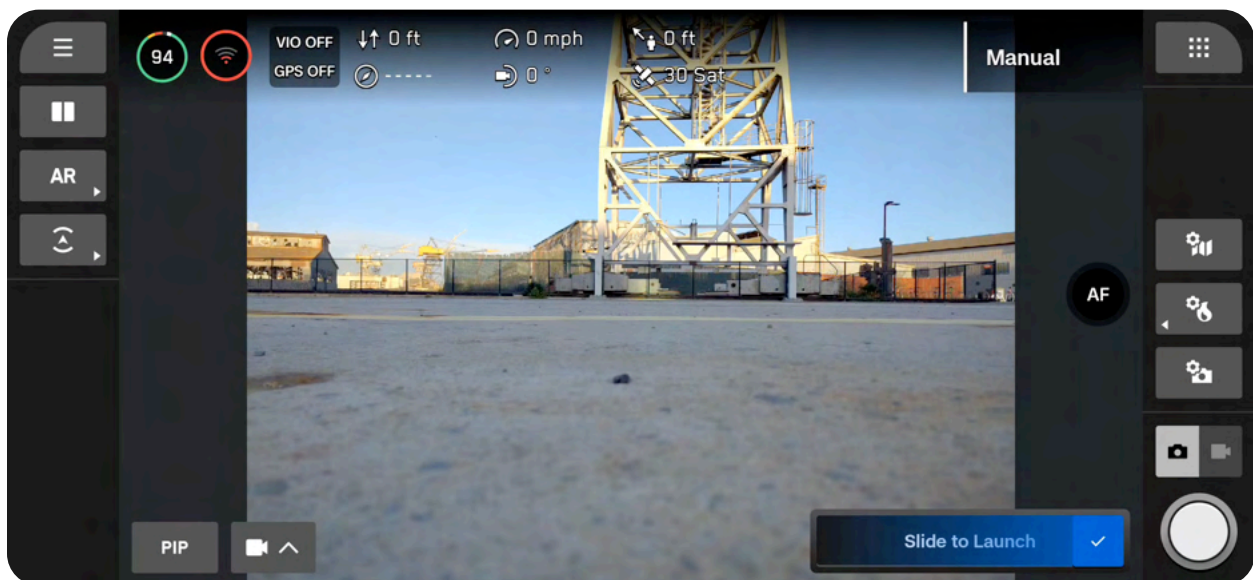
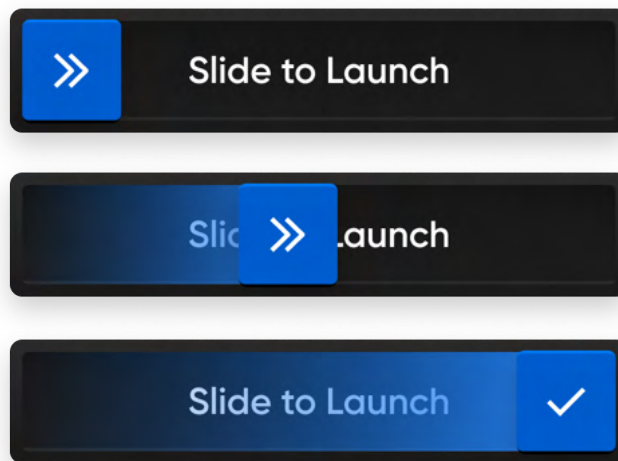

Step 4 - Return Behavior

Set your preferred return location. The drone will autonomously return to this location when the battery level is low or if the drone loses connection.

Use Launch Point - the drone will return to the launch location.

Set Custom Rally Point - manually pilot the drone to a new location and set this as your Rally Point. The drone will return to this location.

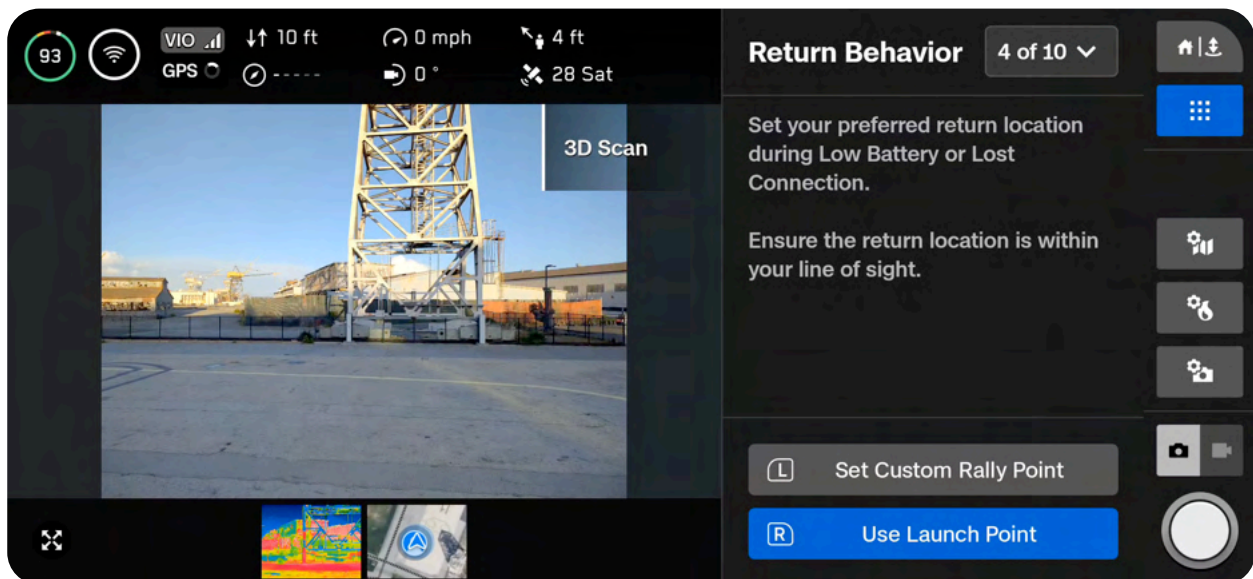

Tips for setting a Rally Point:

- *The Rally Point should be in your line of sight with a clear path to the Launch Point.*
- *Set your Rally Point close to the scan region so that the drone can safely and easily return to that point autonomously. Even if you change position during the scan, the drone will always have a point to return to safely without obstruction.*
- *Choose a location that is safe for landing.*

Step 5 - Set Surface

The Surface defines the area you wish to scan. It will also define the area of your reconstructed model in the **Model Viewer**.

There are two ways to begin setting the Surface:

Use Default Height starts the Surface at 0 ft (0 m) **below** the launch height.

Set Custom Floor Height starts the Surface at the current height of the drone.

When setting a custom Surface, the Launch Height is represented by a light gray AR plane. Adjust as desired:

- Pilot X10 and the Surface will automatically move with the drone as you fly
- Drag the orange Surface AR to the desired height
- **Done** – Sets the Surface in your desired location and proceeds to the next step
- **Center Surface** – Moves the location of the Surface to the current altitude of the drone
- **Level Gimbal** – Moves the camera gimbal pitch to 0°

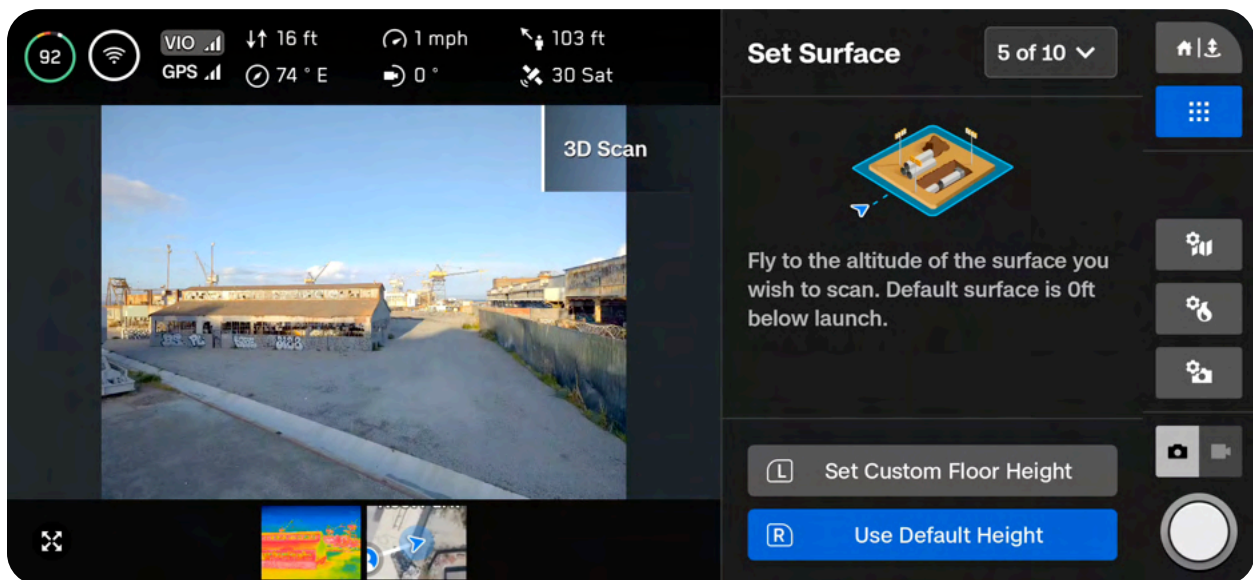

Step 6 - Boundaries

Set pillars to encompass the structure to be scanned. The pillars bound the area laterally. It will also define the lateral area of your reconstructed model in the **Model Viewer**.

A minimum of three pillars must be set to create an area boundary.

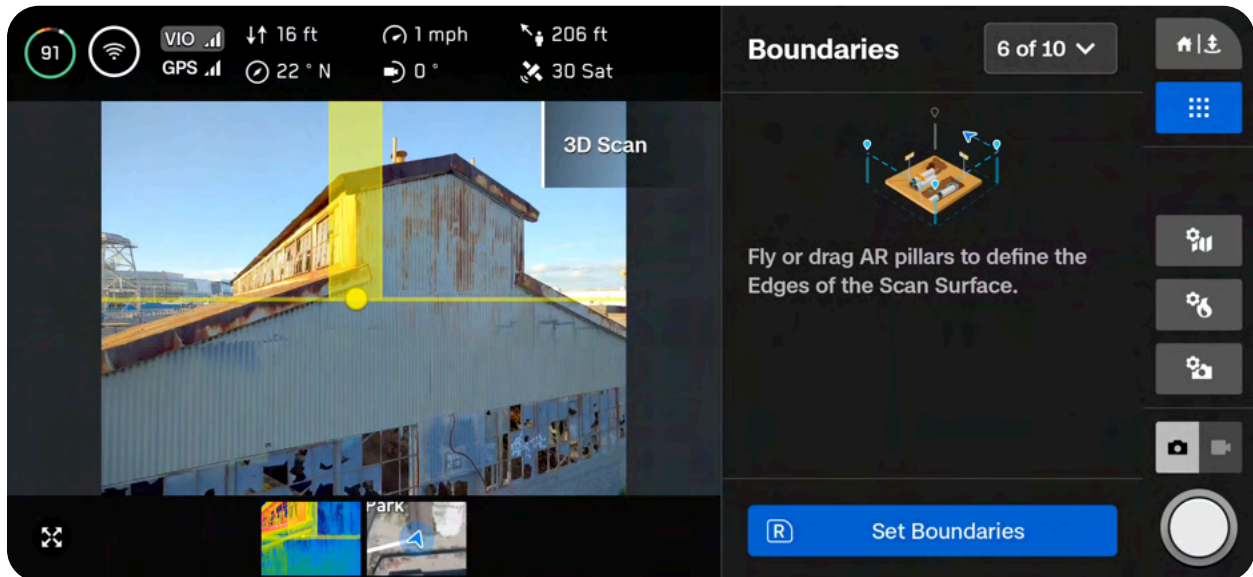

There are two options when setting pillars:

Fly to the desired location and use the right shoulder button to select **Set Pillar**. Continue placing pillars to encompass the entire structure. By default, pillars are attached to the drone. The edges of the polygon defined by the pillars must not cross each other.

- **Set pillar** – Adds a new bounding pillar
- **Remove** – Removes the previous bounding pillar
- **Done** – Completes this step and finalizes pillar placement



TIP: Try adjusting the angle of the gimbal for a better view of where you are placing pillars.

Drag pillars by holding the base of the yellow AR Pillar on-screen. This selects the active pillar and enables dragging. You may continue to set pillars by dragging or reconnecting the pillar to the drone by selecting “Attach.”

- **Set pillar** – Adds a new bounding pillar
- **Remove** – Removes the previous bounding pillar
- **Attach** – Reconnects the pillar to the drone
- **Done** – Completes this step and finalizes pillar placement



INFO: Only the current active pillar may be dragged.

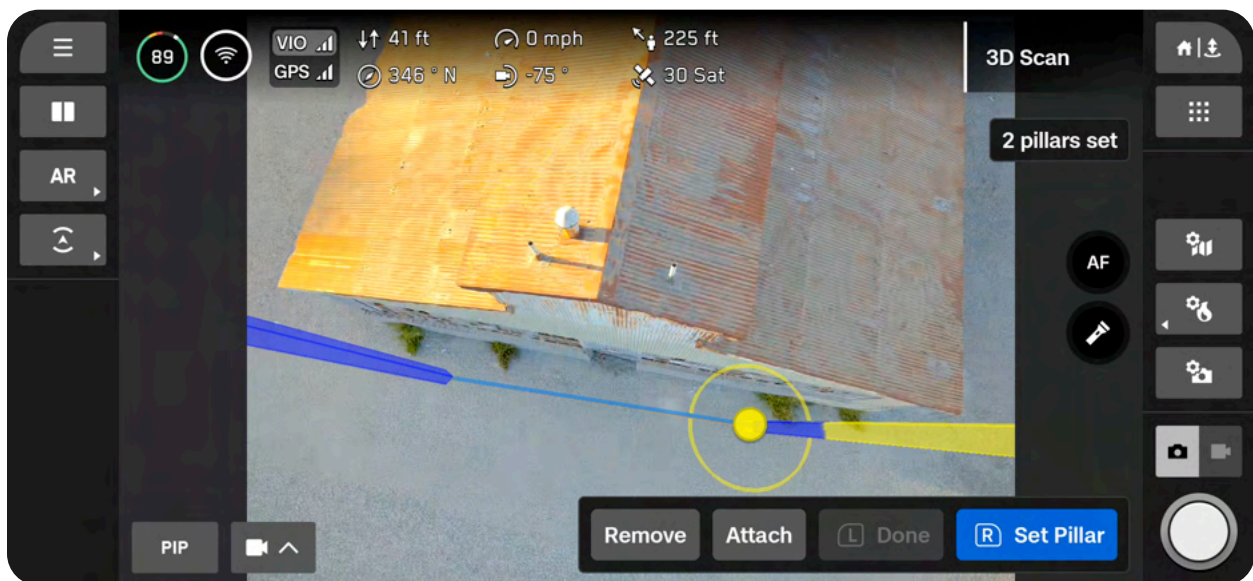

Step 7 - Set AR Observer

The Augmented Reality (AR) Observer allows you to set the point of view from which you can observe an augmented-reality view of the scan progress.

- When you set your AR Observer point, the drone will take a static image from that position
- The AR drone will follow the white lines, which denote the planned flight path and image capture locations
- The purple AR lines show the Wall boundaries (pillars)

There are two options when setting the AR Observer:

Review Suggestion means Skydio will fly to the ceiling of the pillar closest to the launch position. The drone will then face the structure (the centroid of the AR polygon-prism).

Set Custom AR Observer allows you to manually pilot the drone to your preferred vantage point. If you choose to manually set the location of the AR Observer, ensure you are choosing a spot that provides you with the best situational awareness for monitoring the scan's progress.

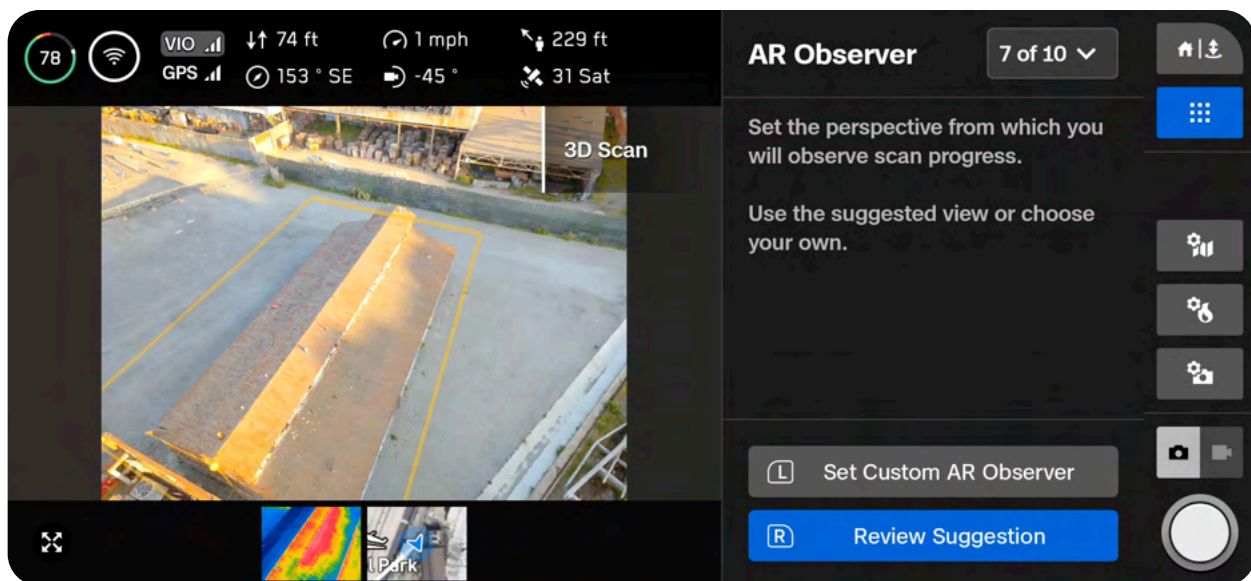

NOTE: The AR Observer is only available for the color camera.

**Tips for manually setting the AR Observer:**

- Tightly frame the structure and fill the frame vertically or horizontally
- Select this option if you are scanning around obstacles or in complex environments

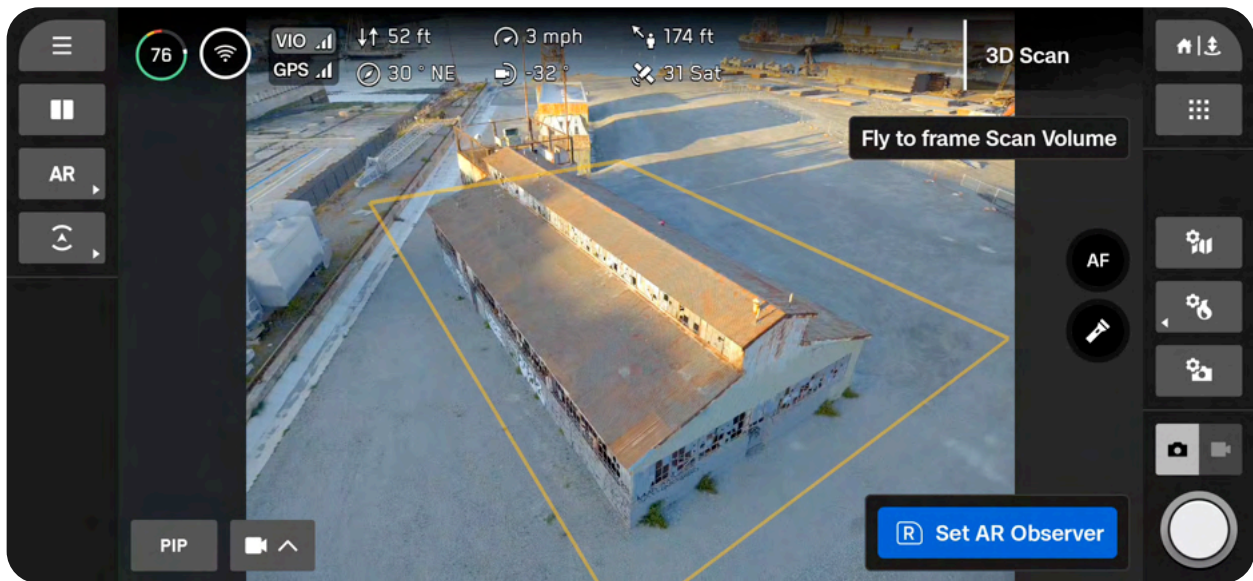

To view the AR Observer, select the **Picture-in-Picture (PIP)** button in the bottom left of the Flight Screen. You also have the option to set this as one of your views in the Single, Split, or Grid Display Layouts.

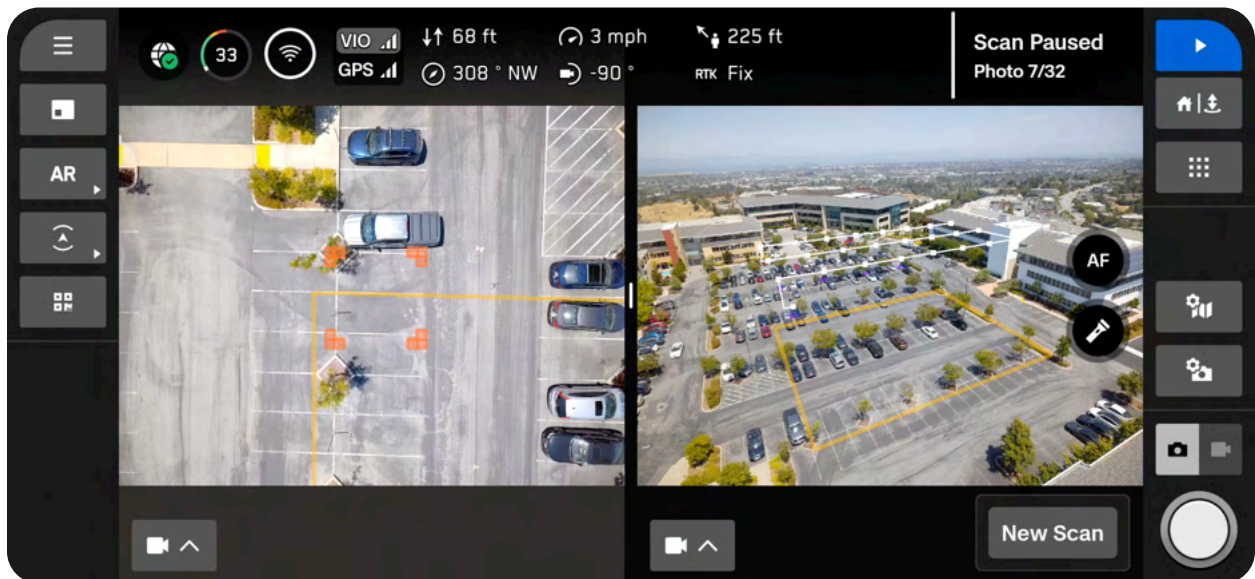
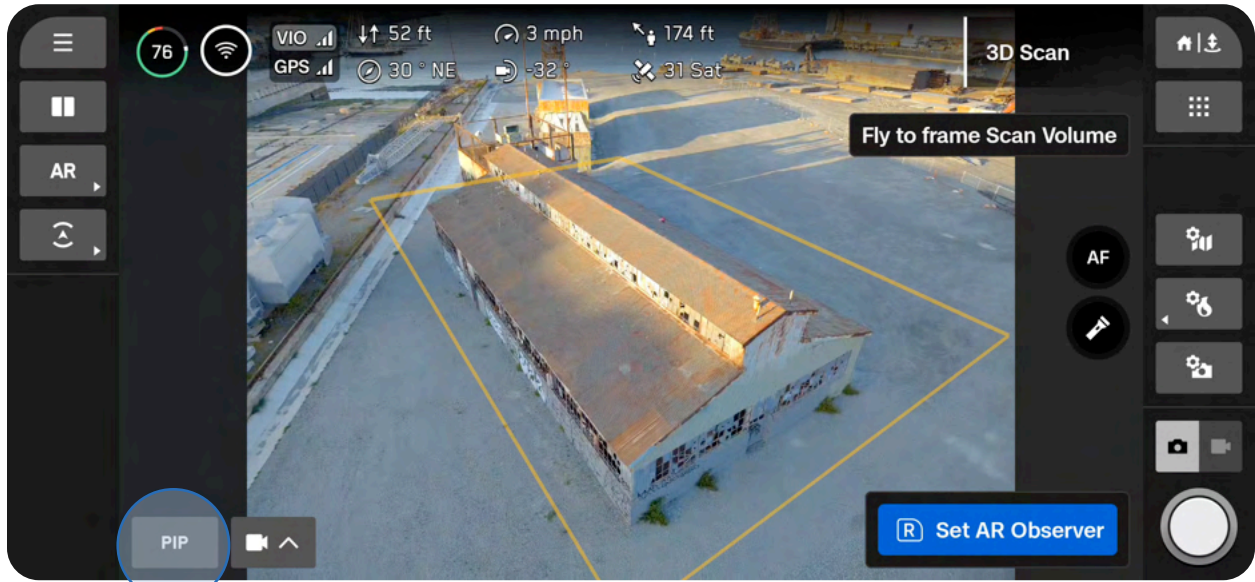

Step 8 - Scan Settings

View a summary of your scan settings, plus estimates for the total scan time, required number of batteries, and total number of photos. You must have at least five photos to begin a scan.

Editing scan settings will impact the total flight time, number of photos and the required number of batteries.

Scan settings include:

- Distance to Surface
- Upward Capture
- Overlap and Sidelap
- Cross Hatch
- Perimeter
- Maximum Speed
- Geofence
- Stop for Photo
- Photo Settings (located in a separate menu)
- Field of View (VT300-L only)

Settings persist across scans of the same scan mode. Select the Reset button at the bottom of the list to restore settings to defaults.



CAUTION: *With Geofence enabled, the drone will stay within the scan area during data capture, but not necessarily during transit to and from the Launch Point.*

The thermal camera has a different Field of View (FOV) compared to the color (RGB) camera. Due to this, the **Overlap, Sidelap, and GSD (Distance to Surface slider)** values for the thermal camera and the color camera are different within the same scan. The values in the workflow pane on the right represent the color camera settings.

- You will see a summary of the thermal (IR) setting values displayed on the bottom of the live camera feed

If you are conducting a thermal scan and want a higher Overlap/Sidelap or GSD, increase these settings in the workflow pane until you reach your desired values.

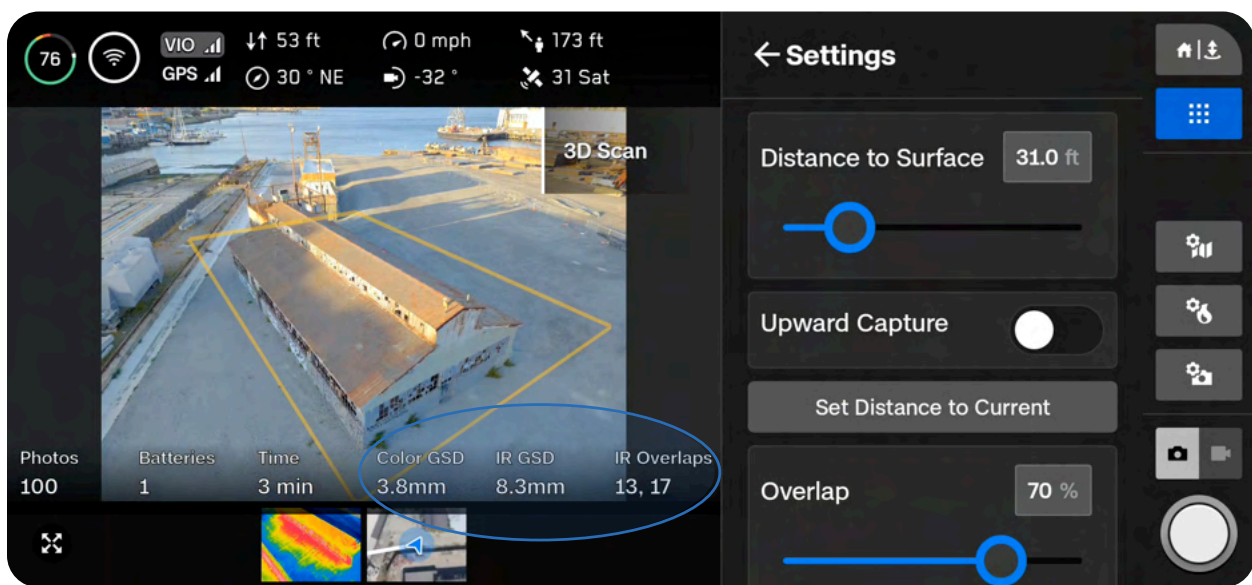

When reconstructing a thermal-only scan, we recommend at least 80/80 Overlap/Sidelap for the thermal sensor.

Intended thermal (IR) Overlap/Sidelap	Corresponding Color Overlap/Sidelap (Wide camera)	Corresponding Color Overlap/Sidelap (Narrow camera)
85/85	95/95	90/90
80/80	93/93	88/88
70/70	90/90	85/85

Photo Settings

You can also adjust your camera settings, including color and thermal camera settings, at this stage. Select the **Color or Thermal camera icons** on the right side of your screen to access your photo settings.

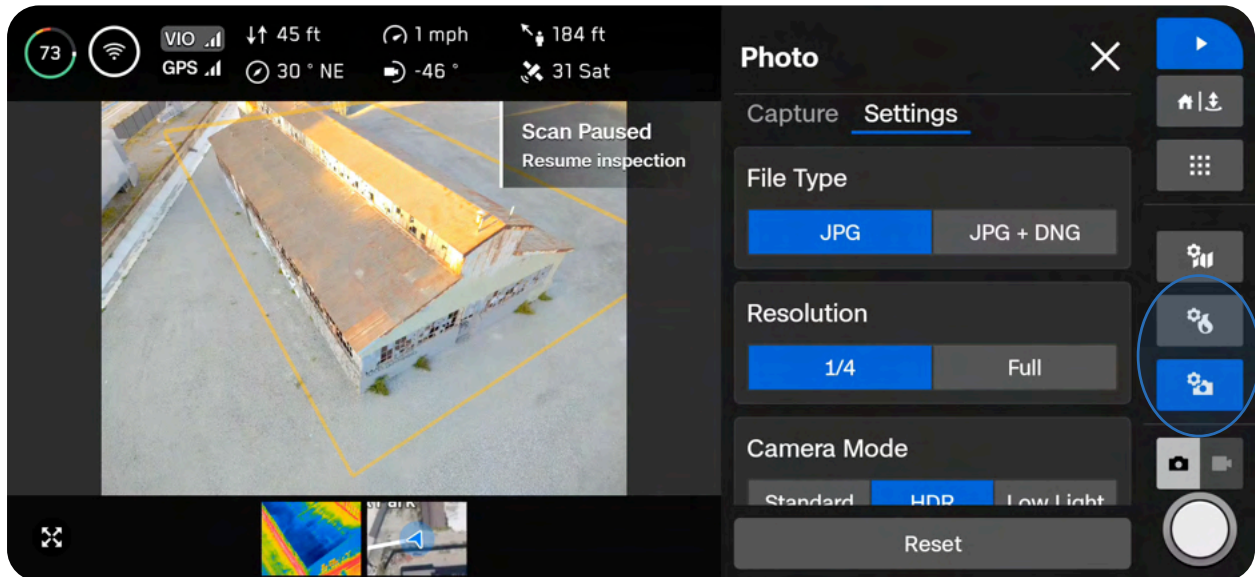

After this step, you will not be able to adjust the following camera settings while scanning:

- Resolution (Full or 1/4)
- Camera Mode (Standard, HDR, Low Light)
- Enabling or disabling thermal JPG or RJPG files
- Enabling or disabling DNG files
- Changing Field of View: Wide vs Narrow (VT300-L only)

If you plan to process your thermal images in an external tool, you must enable RJPG files. Navigate to Thermal Camera > Settings and toggle on RJPG. This will ensure your drone captures radiometric JPG files.

You cannot capture thermal images by themselves. The following two file combinations are available:

- RGB files and Thermal JPG files
- RGB files and Thermal JPG + RJPG files
- If RJPG is enabled, you will also capture thermal JPG

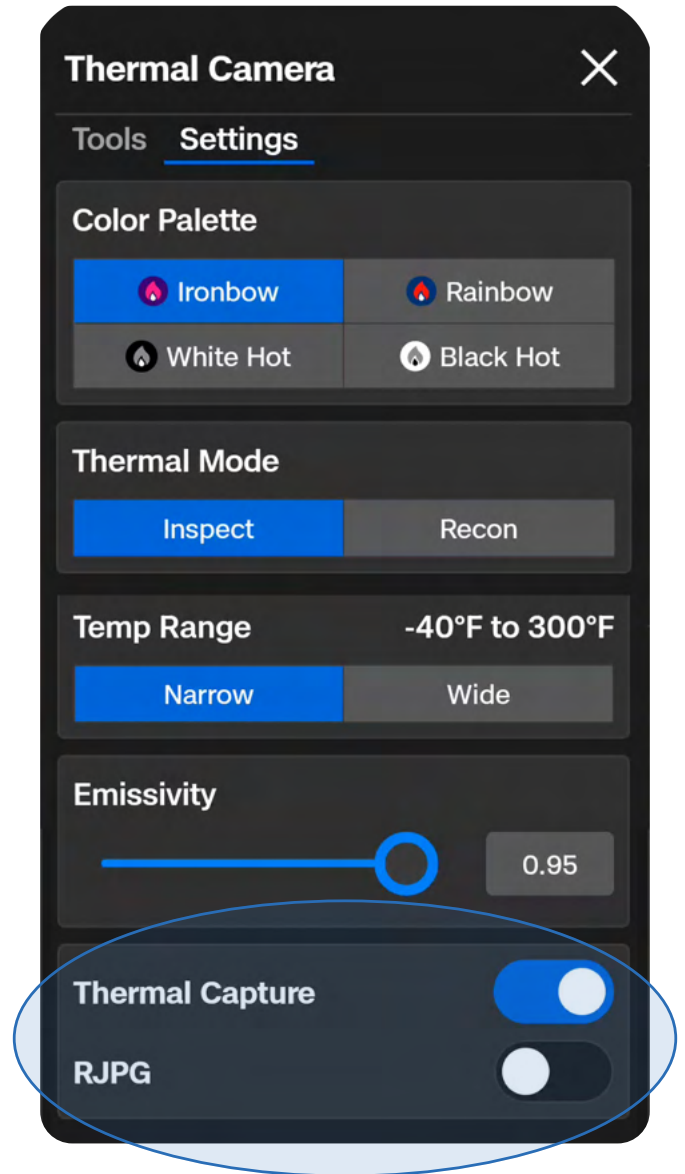

Once your settings are finalized, you may select **Begin Scan** and Skydio will begin autonomously scanning the structure.

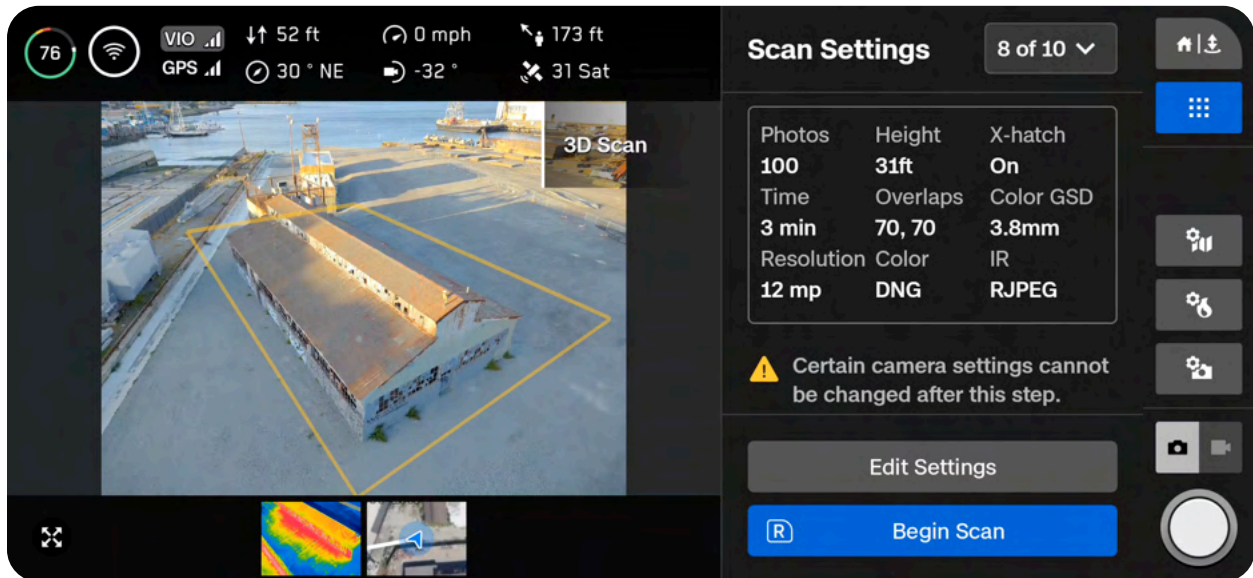

Tips:

- If you plan to fly higher than the Distance to Surface slider allows, simply fly to your desired altitude and select **Set Distance to Current**.
- To scan the underside of a structure, enable **Upward Capture** in the scan settings.
- The Geofence option allows you to enable **Strict Boundaries** that Skydio will not exit while scanning.



CAUTION: Do not set your Height Ceiling below your desired scan altitude as this will impact GSD.

Step 9 - Scan

You will see AR markers showing the scan capture points on the live camera feed.



Optionally toggle on the AR Coverage Mesh during your scan to monitor the photo coverage progress of the scan. *Learn more about this feature in the AR Coverage Mesh section.*



Pause at any point during your scan. Use the left shoulder button or tap this icon in the workflow pane to pause scanning. Skydio will display how many photos have been captured. While paused, you have the option to manually capture photos using the right shoulder button.



Press the play icon or use the left shoulder button to resume autonomous scanning. Use the right shoulder button during a scan to Skip to the next capture point.

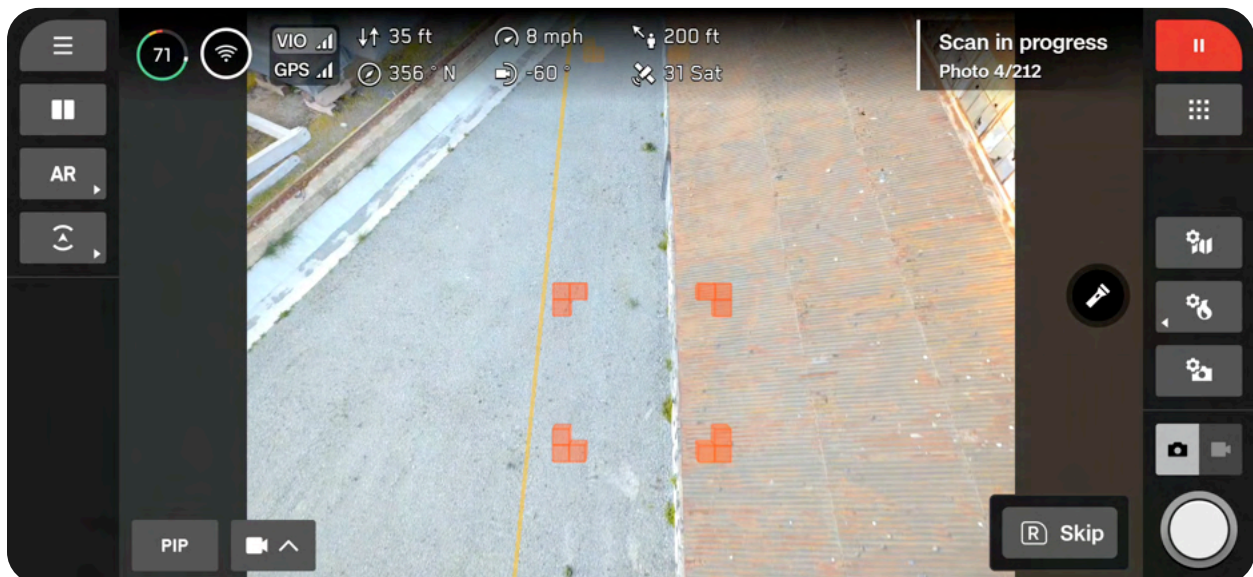

Your scan may require using several batteries to complete. *For information about how to scan with multiple batteries, read the [Scanning with Multiple Batteries](#) section.*



NOTE: *Even if Stop for Photo is disabled, you may see the drone pause, along with a “Saving Photos” notification. This is to ensure the SD card finishes writing the data. Autonomous scanning will resume automatically.*



CAUTION: *Ensure you have enough battery to complete the scan setup and begin scanning. You will only be able to save the progress of a scan once scanning begins. If your battery dies before scanning begins, you will need to restart the scan setup after replacing the battery.*

Step 10 - Scan Complete

Upon completing the scan, Skydio will automatically fly laterally to the Launch Point at the scan height (Distance to Surface).

- Skydio will first fly laterally until it is above or below the chosen point and then move vertically to reach it
- When it reaches the Launch Point, it will descend until it is 16 ft (5 m) above the Launch Point
- You will have the option to start a new scan, or you can initiate a landing

You will have the option to either start a **New Scan** or **Land**.

After landing, you will see a summary of the most recent scan and the option to **Save** or **Discard** the scan you completed.

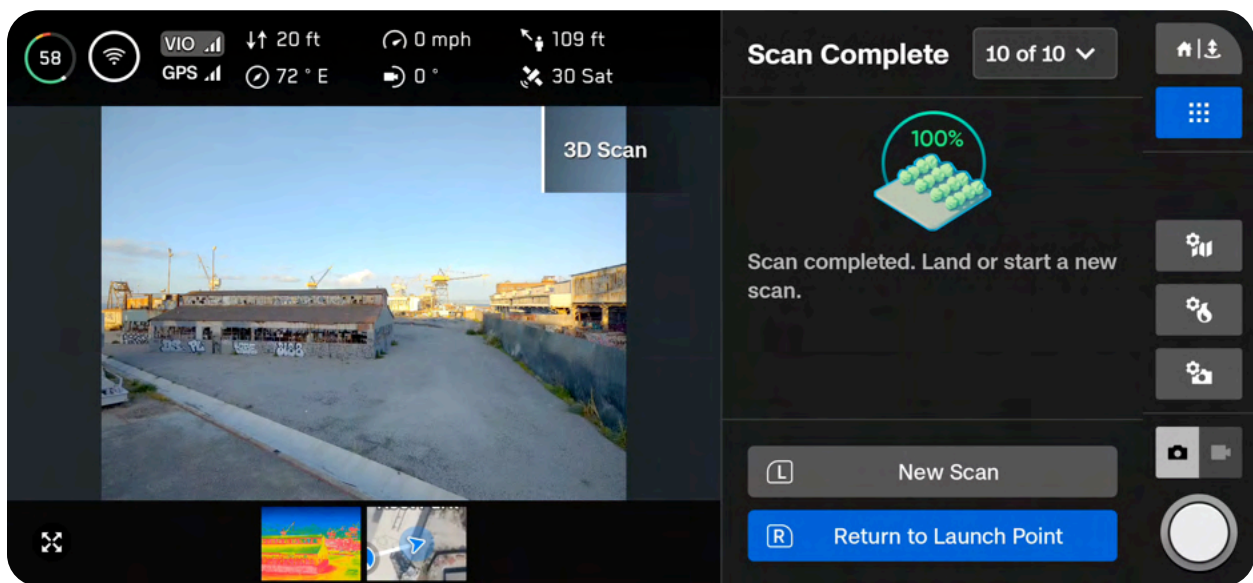

CAUTION: With Geofence enabled, the drone will stay within the scan area during data capture, but not necessarily during transit to and from the Launch Point.

Step 11 - Post-processing

After saving your scan, you will have the option to create a textured model. This model is created onboard the drone and takes several minutes to complete.

If you select **No**, you will still need to wait a few minutes for the drone to process your scan. This is an important step to ensure your media is grouped by scan and saved properly.

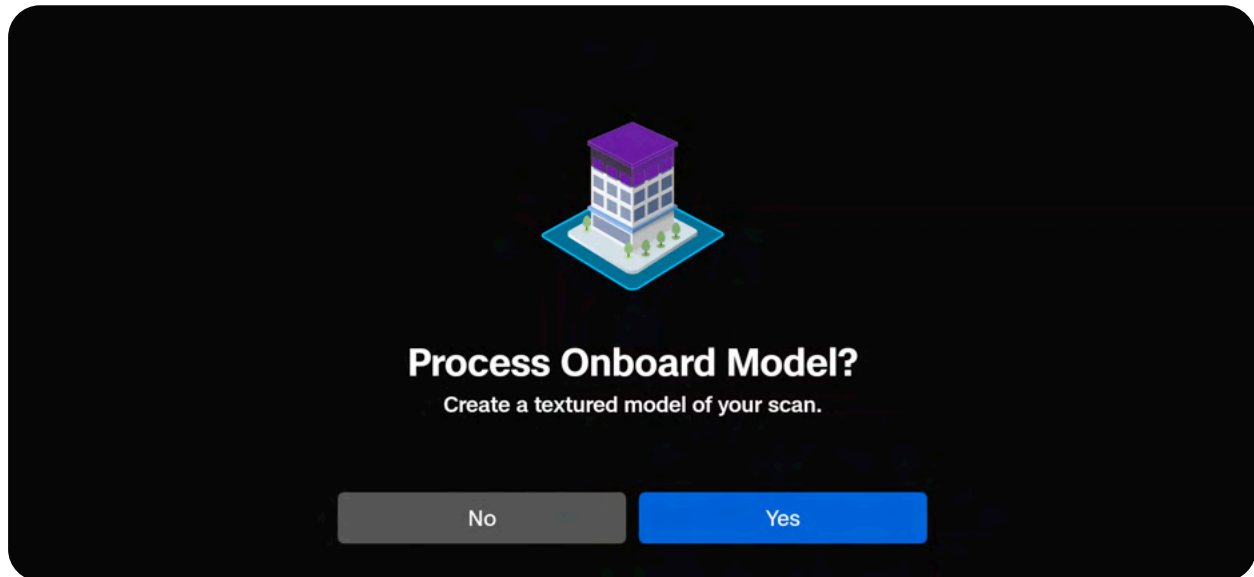

NOTE: If you do not generate an Onboard Model at this point, you will still have the option to generate one at a later time. For multi-battery scans, select **Yes** to generate an Onboard Model **after all flights are completed**.

If you select **Yes**, your drone will first process your scan and then the Onboard Model.

- Onboard Model creation uses HD thumbnails (1920x1440) and processes about 30 images per minute
- Model generation may take longer for larger scans (1000+ images)
- If the battery is low and you are processing a large model, ensure the drone is plugged into a power source

Once processing is complete select **Exit** to return to the Gate Screen or **Review Scan** to enter the Onboard Model Viewer.

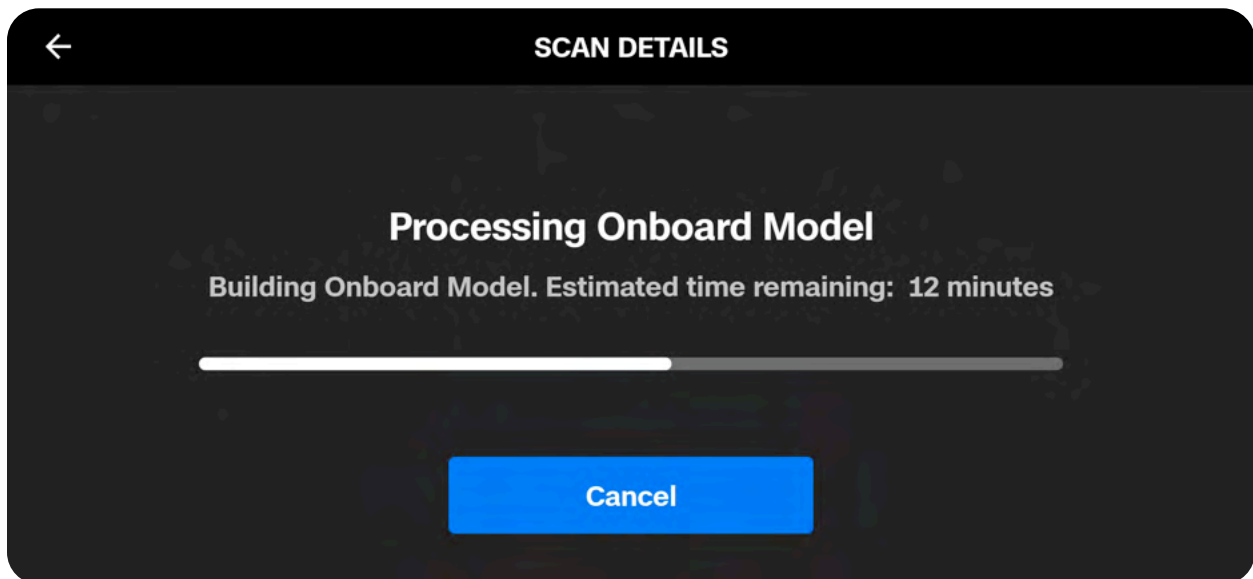

CAUTION: Do not remove the battery or power off during post-flight processing. Doing so will result in loss of data. Do not power off or disconnect from the drone until processing is complete.

Upward Capture

How to scan the underside of a structure: Bridge Use Case

In order for Skydio to capture the underside of a bridge, you must enable the toggle called **Upward Capture** located in the scan settings.

Skydio will **automatically move the camera gimbal pitch to look up** when it detects the height of the drone is below the specified scan Surface.

- You may notice that the sensor package rolls by 180 degrees to look up and reach a pitch above 80 degrees. This is expected behavior given the mechanical design of X10.

Best practices and recommendations

- Enable **Stop for Photo** or **1/4 Resolution** when scanning the underside of a structure in low-lit environments
- When scanning narrow bridges, set your pillars underneath or at the edge of the bridge to help the drone relocalize during multi-battery scans
- **Keep in mind** the height below the surface will be equal to the difference between the Surface height and scan height
- When scanning homogenous surfaces, such as solid steel or concrete structures, we recommend increasing your Distance to Surface
- Scanning too close to such structures may result in difficulties when creating a reconstruction
 - For **VT300-Z** users we highly recommend increasing one of the following:
 - Distance to Surface (about 32 ft/10 m)
 - Overlap/Sidelap (85% / 85%)



CAUTION: *If you are flying with a sensor package that has a thermal sensor, please note that pointing a thermal camera into direct sunlight may cause permanent damage to the sensor.*

The example image below shows a proper setup to capture the underside of the bridge.

- After setting the scan Surface in this scenario, enable Upward Capture in the scan settings
- The sensor package angle will automatically look up to capture the underside of the bridge

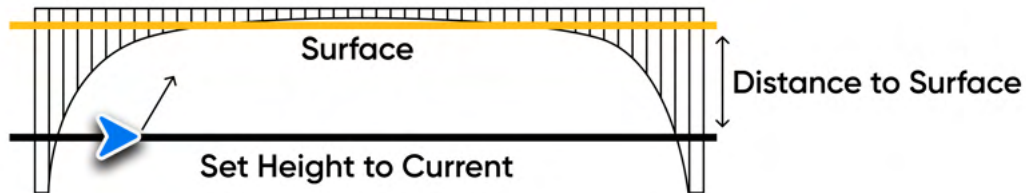

In the second example image below, the user has set the Surface to cover the bridge deck, and the altitude of the drone is above the scan Surface.

- In this scenario, the Distance to Surface can be set one of two ways: using the distance slider or by flying to the desired altitude and selecting **Set Distance to Current**
- The sensor package angle will automatically look down to capture the bridge deck
- Using the Set Distance to Current feature is not a requirement when capturing the top of a bridge

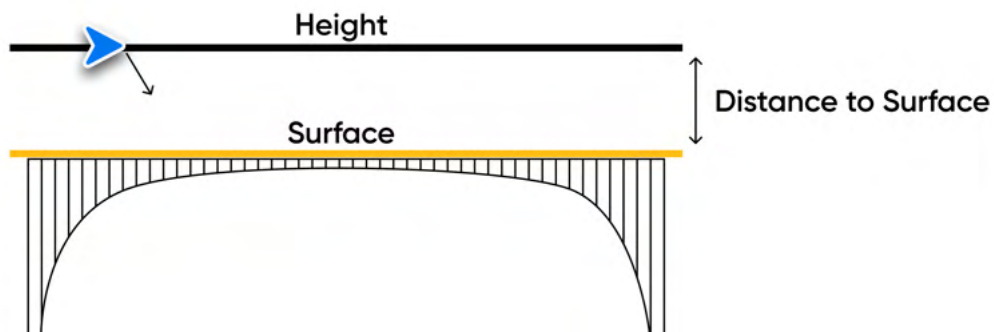

Recommendations for 3rd party photogrammetry engines

DroneDeploy

To process a successful 3D model of an Upward Capture, ensure you select Vertical Model

1. Create or open a project in DroneDeploy
2. Set the scan location on the map
3. Select the **Upload tab** located at the top of the screen
4. Select **New Upload**
5. Select Vertical Model
6. Upload your scan photos

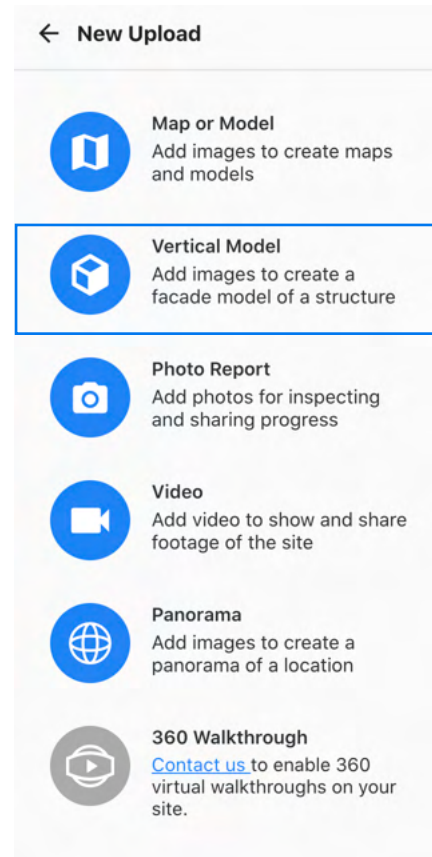

Indoor Capture Workflow

Overview

Before you fly:

- GPS is not required for Indoor Capture
- Be aware of thin obstacles such as wiring from ceiling lights
- Ensure the room is clear of small objects that could be affected by propeller downwash
- Do not scan in confined environments that are dimly lit
- Skydio does not avoid transparent or reflective surfaces, such as windows or mirrors greater than 60 in (152 cm)
- If needed, you can move backwards and re-do any steps in the workflow. Doing so will reset the steps you have already completed and discard any media that has been captured.
- **Indoor Capture is not recommended with Narrow camera.** If you plan to scan using this sensor package, we recommend setting a large Distance to Surface.



Indoor Capture scanning tips:

- *The placement of the drone determines the angles at which it will capture photos during the X and Y passes. Consider placing the drone **parallel** to a wall (45°) to introduce more parallax for reconstructions.*
- ***If your scan will require more than one battery, take note of the exact position and orientation of launch.***
- *Set the Floor as low as possible. Set the Ceiling as high as possible, keeping it below any obstructions such as wires or lighting.*
- *If you wish to scan the entire room, set the Wall AR pillars as close to the walls or edges of the room as possible.*
- *Enable **Scan Outside Pillars** if you wish to capture surfaces located outside of your scan volume.*
- *Use **1/4 Resolution** when scanning in low light indoor environments.*
- *Ensure **Stop for Photo** is **ON***
- *If you are creating a reconstruction with DroneDeploy, use the **Facade** upload type.*

Refer to the table below for the default settings in this mode. For more detailed information about each setting, view the 3D Capture Settings section.

- Define the **Floor, Ceiling** and **Wall Boundaries** to create your **Inside Scan Volume**.
- By default, Indoor Capture extends the Inside Scan Volume by 16 ft (5 m) to incorporate spaces where the drone cannot physically fly, which creates the **Outside Volume**.
- Choose if you want to scan the Inside Volume only, Outside Volume only, or both volumes.
- Skydio will face outward to capture features located outside of the scan volume.
- Use the map to set a custom scan location when flying in GPS-denied environments.
- All Strict Geofence boundaries are **ON** by default, meaning Skydio will not physically leave the Inside Volume.

Setting	Default
Strict Geofence	All bounds ON by default
Extend Volume	Floor, Ceiling, and Walls enabled by default Distance is set to 16 ft (5 m)
Gimbal angle	0°
Scan passes	Z, Y, X enabled
Overlap/Sidelap	70/70
Speed <i>(applies when exploring and scanning)</i>	8 mph (3.5 m/s)
Other settings ON by default	Take Best Photo Optimize X, Y



CAUTION: Follow the [Skydio Safety and Operating Guide](#), as well as all civil aviation authority regulations and applicable local and federal laws.

Understanding the Visual Geofence and Extend Volume in Indoor Capture

By default, all boundaries are set to a **Strict Geofence**. This means the drone will not fly outside of the Floor, Ceiling, or Wall boundaries.

By default, **Extend Volume** is enabled for all bounds. Indoor Capture extends the Inside Scan Volume by 16 ft (5 m) to incorporate spaces where the drone cannot physically fly, which is referred to as the Outside Volume.

There may be cases where you want to capture features that are outside of the initial scan volume, requiring an “outside in” view. In this case, select **Edit Volume** during the **Extend Volume** step and enable **Scan Outside Pillars**. From here, edit the state of any relevant Strict Geofences.

- When a Strict Geofence is **OFF**, this means Skydio will move freely inside and outside of the scan volume
- If you leave a Strict Geofence **ON**, Skydio will skip image capture points that are located outside that boundary, which may result in gaps in coverage



WARNING: Ensure your indoor environment is safe (i.e. spacious and brightly lit), before turning off any Strict Geofence.

EXAMPLE: You are trying to capture all interior contents of a room, as well as the surfaces of the walls.

The room you are scanning has thin wires on the ceiling for lighting. When scanning an environment like this, it's important to take extra care to ensure the drone can safely navigate the space.

Aside from the wires, the room is well lit and clear of other obstacles and safety concerns.

- Set the Ceiling as high as possible while still staying below the wires
- Leave the **Strict Ceiling ON** to ensure that the drone stays within the boundaries of the scan volume

In this scenario, it may be possible to **disable** the **Strict Geofence** for the Floor and Walls, allowing the drone to fly freely throughout the interior of the room and the scan volume.

- With a **Strict Ceiling ON** and all other **Strict Geofence** bounds **OFF**, this means that after the drone exits the scan volume, it will rotate to face the volume and in turn capture the “outside in” views

Scan Setup

Step 1 - Scan Mode

Select **Indoor Capture** as the Scan Mode. Tap **Select Scan Mode** on the screen or use the right shoulder button on the controller to confirm your selection.

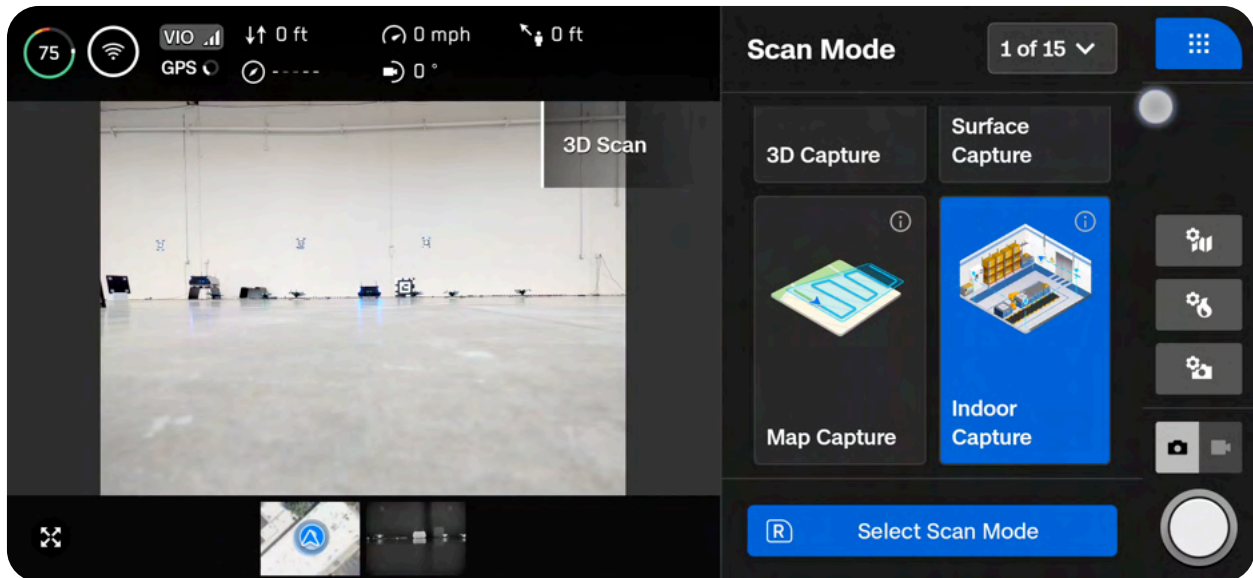

Step 2 - Scan Name (optional)

You may optionally rename your scan. The default scan name is composed of the scan mode you select followed by a UTC timestamp. Renaming the scan will replace the scan mode.

- Ex: Surface_Capture__2024-05-20T19-50-55.135854+00-00

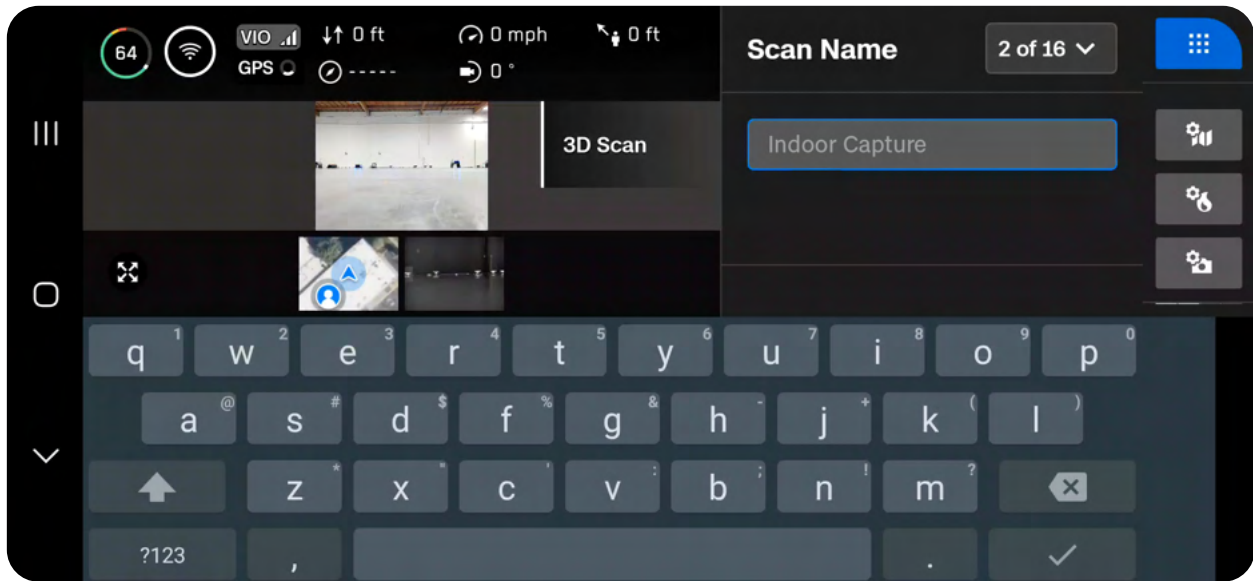

NOTE: Scan names must use American Standard Code for Information Interchange (ASCII) characters. You will be prevented from using unicode characters such as à, é, â, ü, ö, ä and the following symbols: < > : ; , \ | ? * & \$ { } ` “ Visit skydio.com/support for more information.

Step 3 - Set GPS Location

Using a satellite map, set the GPS location of your scan site and define the heading of the drone. The location and heading you set will be used in the GPS metadata of your scan photos.

There are two ways to set your GPS location:

Use Best Guess means Skydio will attempt to estimate your current location. Photo GPS locations will reflect the location of the drone at each capture point. If you are in a fully GPS-denied environment, all photos will have a 0,0 location.

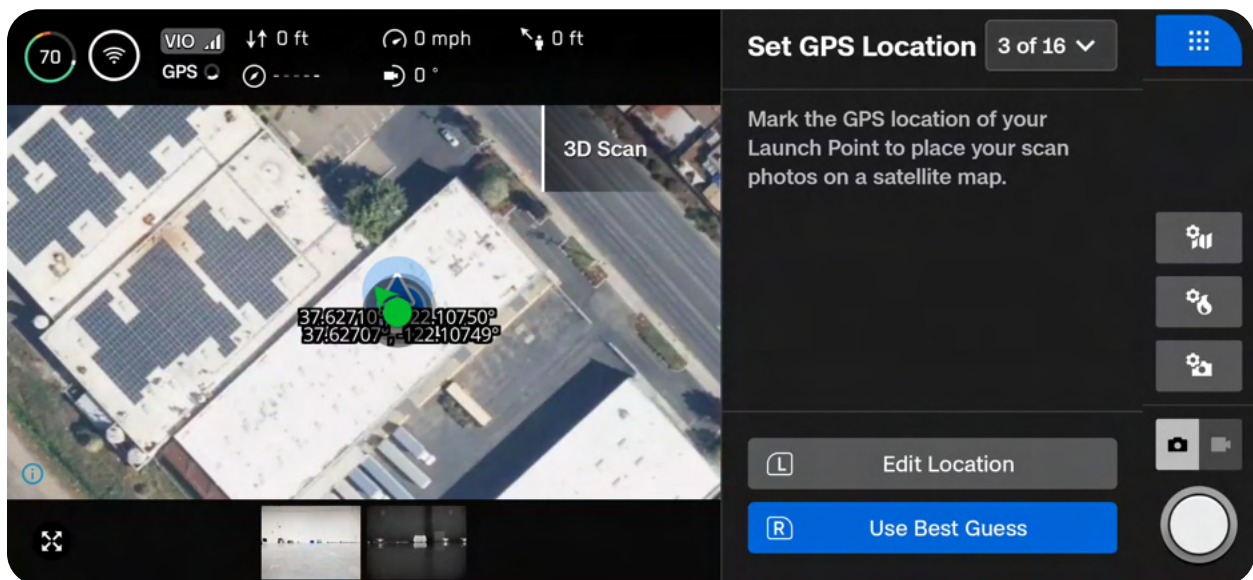

Edit location allows you to manually mark the location of your scan site and drone position. Touch and drag the blue arrow to set the position of your drone, and use the **Heading** slider to adjust its orientation.

- Optionally use the **search bar** on the right of your screen to enter a specific location or coordinates
- Pinch and drag your fingers away from each other to digitally zoom in
- Pinch and drag your fingers toward each other to zoom out

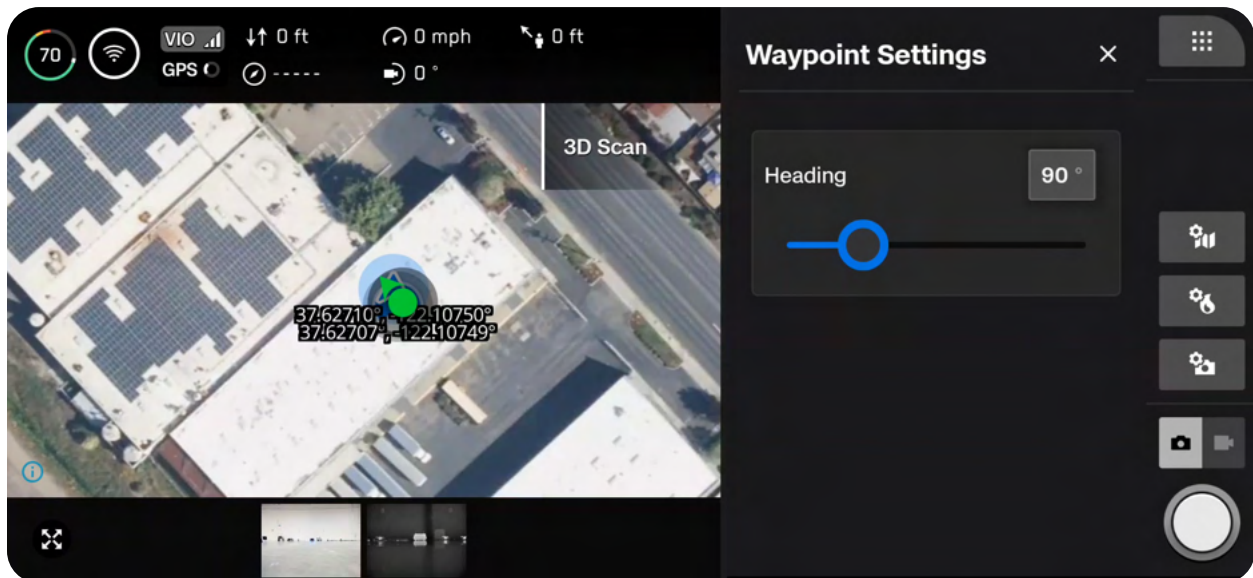

Step 4 - Launch

Drag the on-screen slider or press and hold the Launch/Land button on your controller to begin your flight. The drone will launch, automatically rotate 360 degrees, climb to 6.5 ft (2 m), and hover.

Take note of your launch orientation. If your scan requires multiple batteries, you will need to place the drone in the exact same location and orientation after replacing a battery.

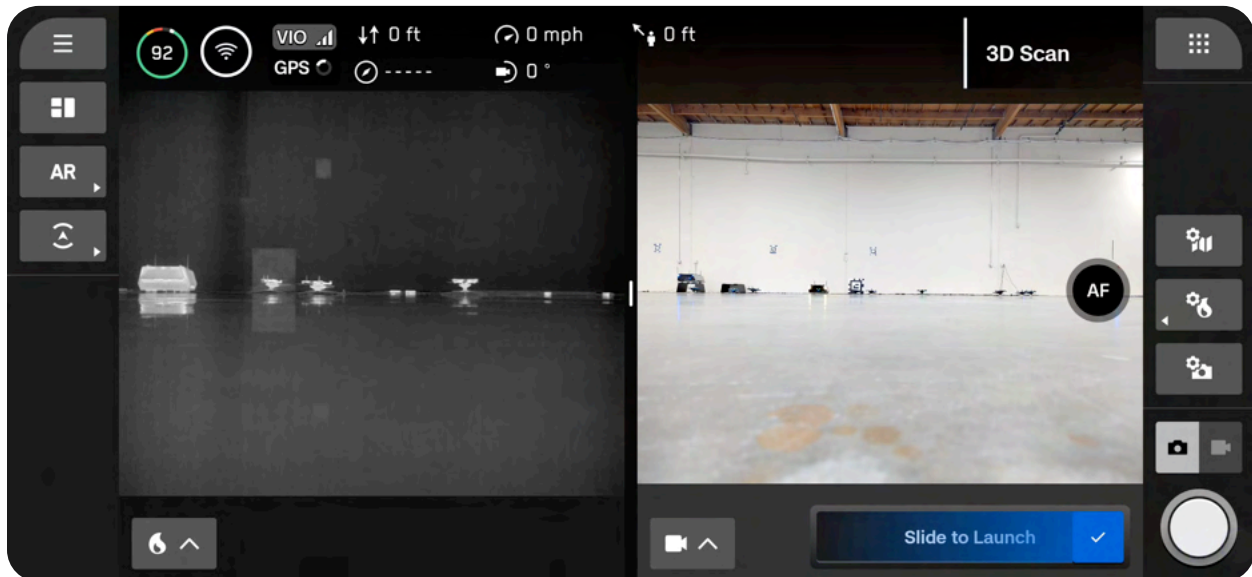
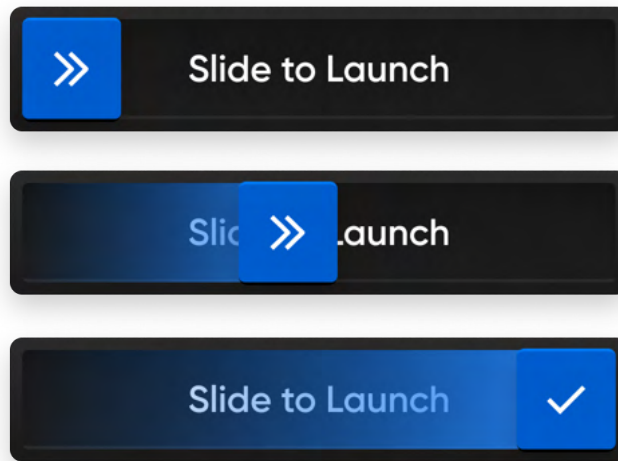

Step 5 - Return Behavior

Set your preferred return location. The drone will autonomously return to this location when the battery level is low or if the drone loses connection.

Use Launch Point - the drone will return to the launch location.

Set Custom Rally Point - manually pilot the drone to a new location and set this as your Rally Point. The drone will return to this location.

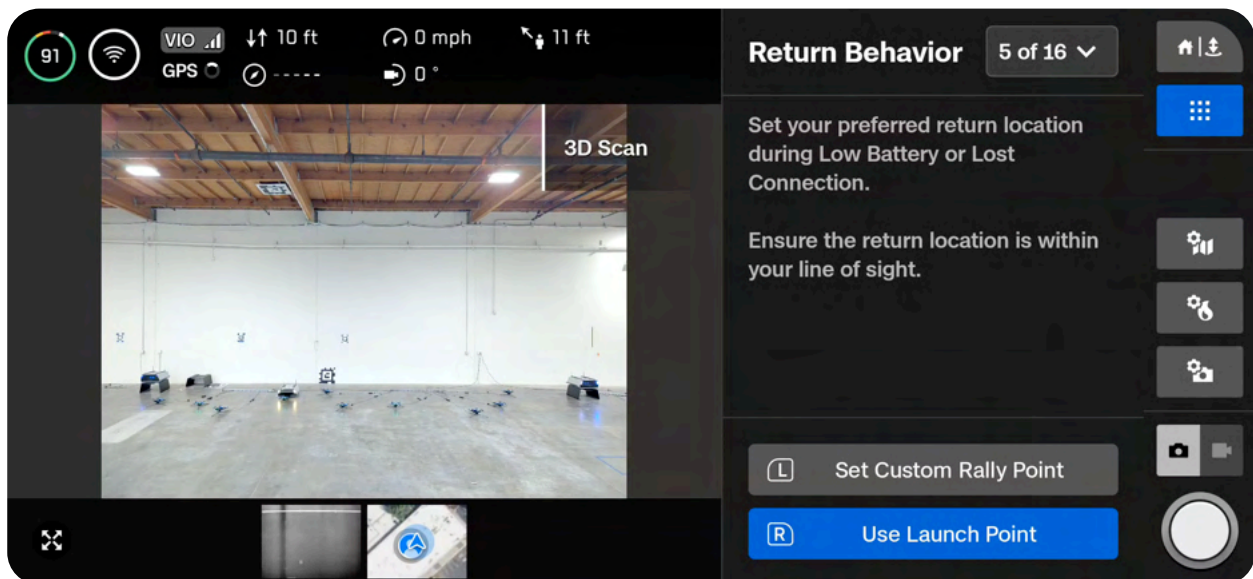

Tips for setting a Rally Point:

- *The Rally Point should be in your line of sight with a clear path to the Launch Point.*
- *Set your Rally Point close to the scan region so that the drone can safely and easily return to that point autonomously. Even if you change position during the scan, the drone will always have a point to return to safely without obstruction.*
- *Choose a location that is safe for landing.*

Step 6 - Floor

The Floor defines the bottom of the 3D volume you wish to scan. It will also define the bottom of your scan in the **Visual Geofence** and the **Model Viewer**.

There are two ways to begin setting the Floor:

Use Default Height starts the Floor at 1.6 ft (0.5 m) **above** the launch height. To ensure the ground is captured, Extend Volume > Below Floor is toggled on by default.

Set Custom Floor Height starts the Floor at the current height of the drone.

Once selected, adjust the Floor as desired:

- Pilot X10 and the Floor will automatically move with the drone as you fly
- Drag the orange Floor AR to the desired height

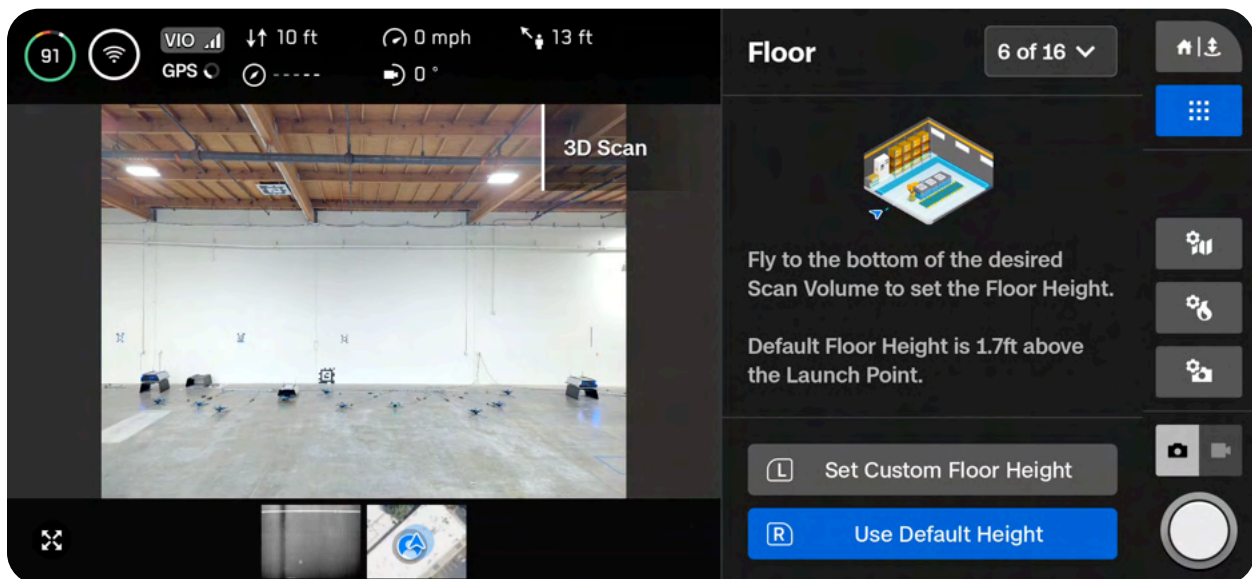

The Launch Height is represented by a light gray AR plane.

- **Done** – Sets the Floor in your desired location and proceeds to the next step
- **Center Floor** – Moves the location of the Floor to the current altitude of the drone
- **Level Gimbal** – Moves the camera gimbal pitch to 0°

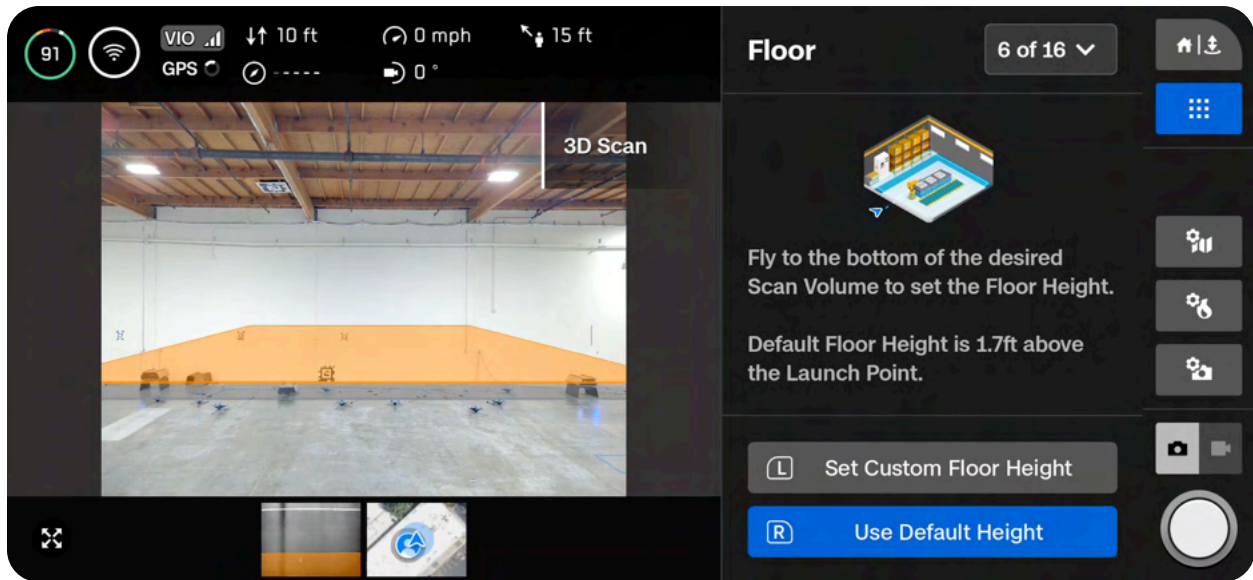

Step 7 - Ceiling

The Ceiling defines the top of the 3D volume you wish to scan. It will also define the top of your scan in the **Visual Geofence** and the **Model Viewer**.

Press R to begin. The workflow pane will collapse to show a full-screen view of the green Ceiling AR. The Ceiling needs to be set above both the Floor and the structure you are scanning.

Once selected, adjust the Ceiling as desired:

- Pilot X10 and the Floor will automatically move with the drone as you fly
- Drag the green Ceiling AR to the desired height

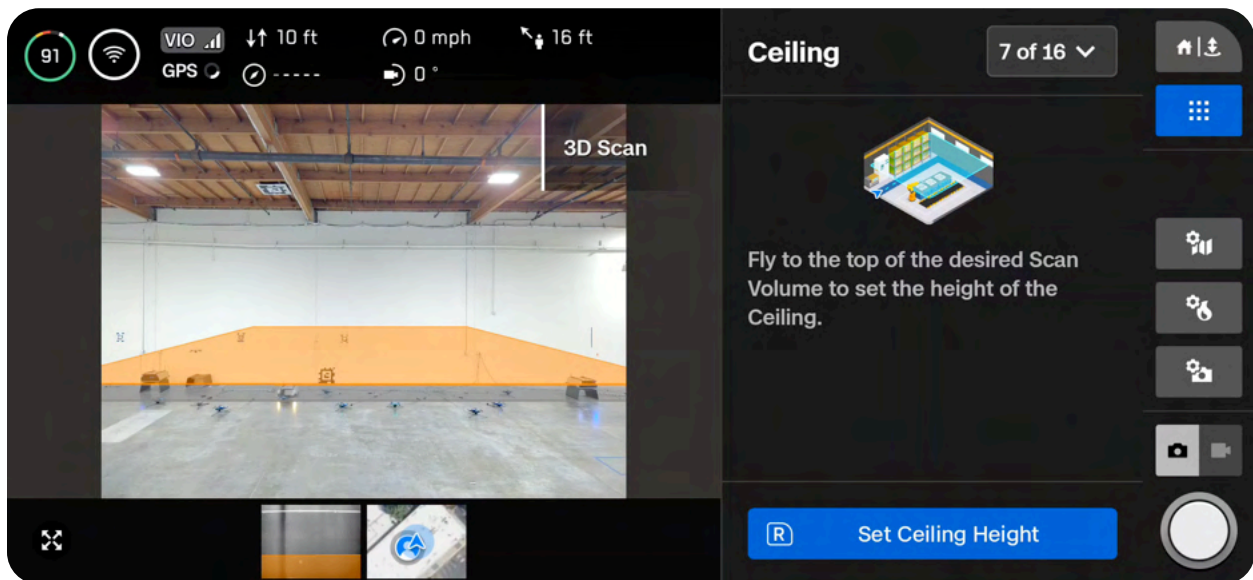

Use the controller shortcuts to navigate the setup process.

- **Done** – Sets the Floor in your desired location and proceeds to the next step
- **Center Floor** – Moves the location of the Floor to the current altitude of the drone
- **Level Gimbal** – Moves the camera gimbal pitch to 0°

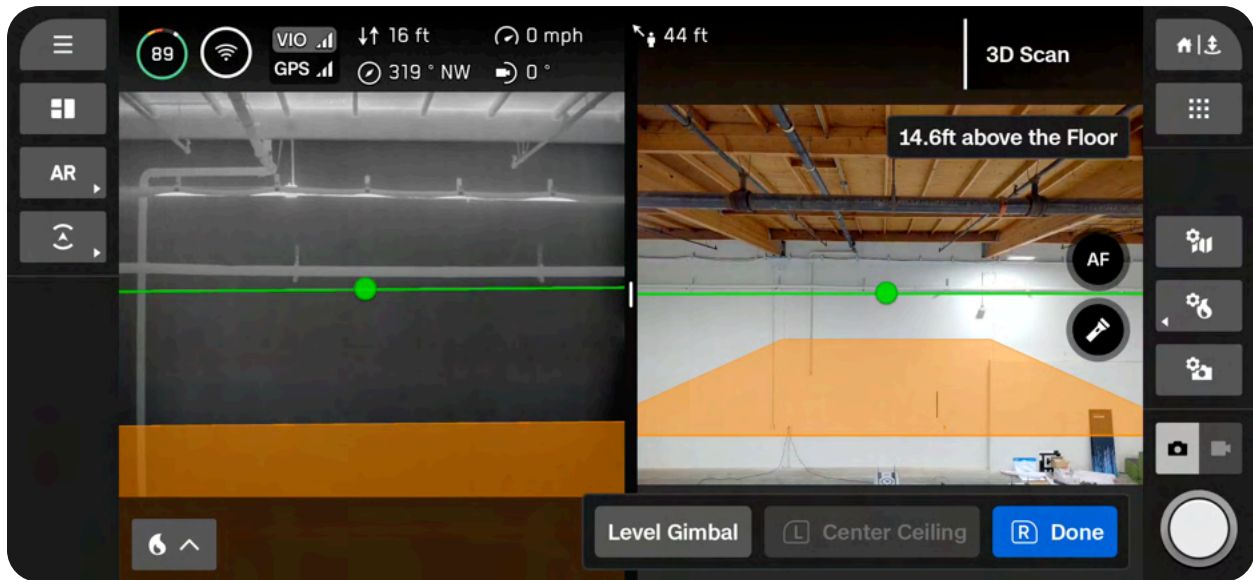

Step 8 - Boundaries

Set pillars to encompass the structure to be scanned. These pillars define the lateral bounds, or walls, of the **Visual Geofence**. It will also define the lateral area of your model in the **Model Viewer**.

A minimum of three pillars must be set to create a 3D volume.

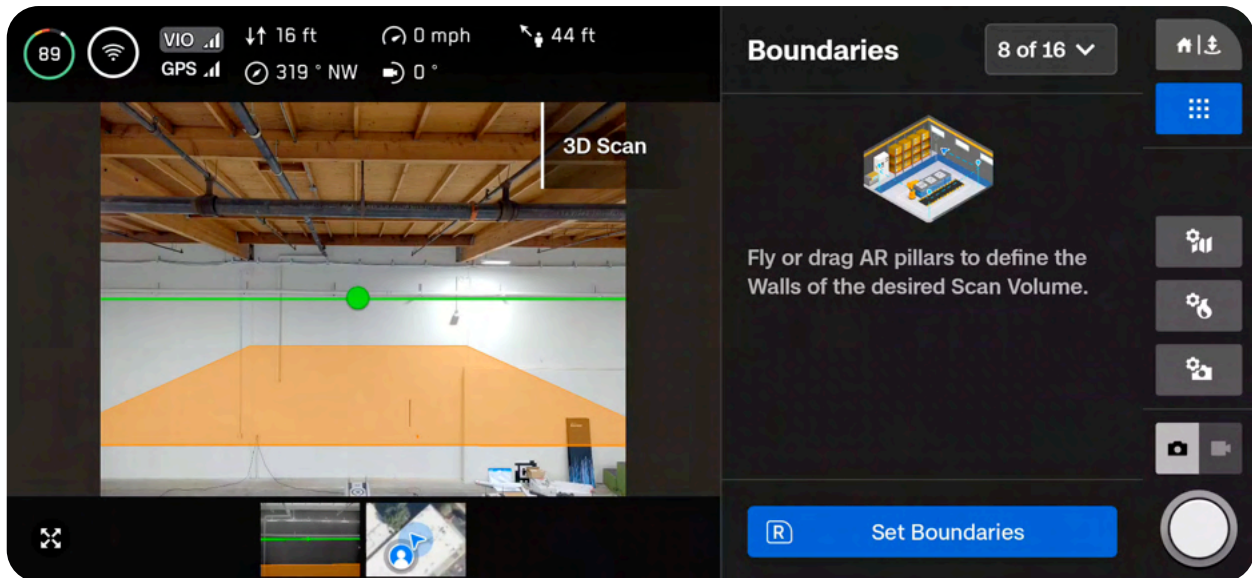

There are two options when setting pillars:

Fly to the desired location and use the right shoulder button to select **Set Pillar**. Continue placing pillars to encompass the entire structure. By default, pillars are attached to the drone. The edges of the polygon defined by the pillars must not cross each other.

- **Set pillar** – Adds a new bounding pillar
- **Remove** – Removes the previous bounding pillar
- **Done** – Completes this step and finalizes pillar placement



TIP: Try adjusting the angle of the gimbal for a better view of where you are placing pillars.

Drag pillars by holding the base of the yellow AR Pillar on-screen. This selects the active pillar and enables dragging. You may continue to set pillars by dragging or reconnecting the pillar to the drone by selecting “Attach.”

- **Set pillar** – Adds a new bounding pillar
- **Remove** – Removes the previous bounding pillar
- **Attach** – Reconnects the pillar to the drone
- **Done** – Completes this step and finalizes pillar placement



INFO: Only the current active pillar may be dragged.



NOTE: The scan volume is automatically extended by 16 ft (5 m), meaning there is no need to drag your pillars behind a wall.

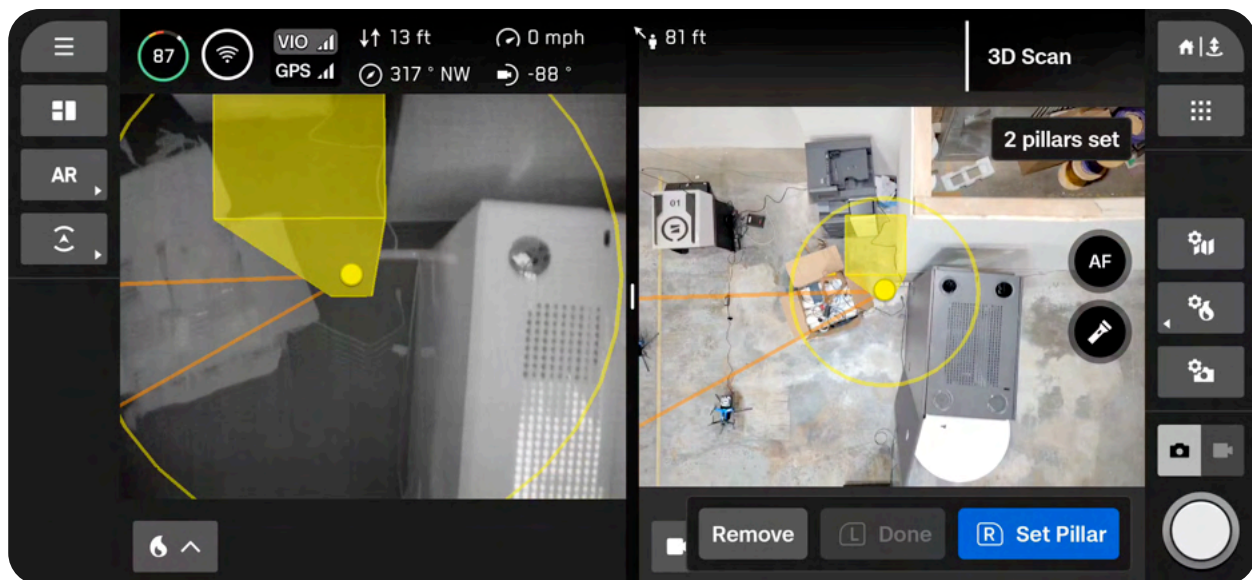

Step 9 - Extend Volume (optional)

This optional step allows you to extend the scan volume beyond the Floor, Ceiling or Walls to capture surfaces outside the boundaries.

By default, your scan area is extended by 16 ft (5 m) along all bounds.

Use the adjustable distance slider to set the distance at which Skydio will capture photos outside of the scan volume.

- Maximum distance: 26 ft (8 m)

If a **Strict Geofence is enabled**, the drone will capture photos of surfaces located outside of the scan boundaries without physically flying there.

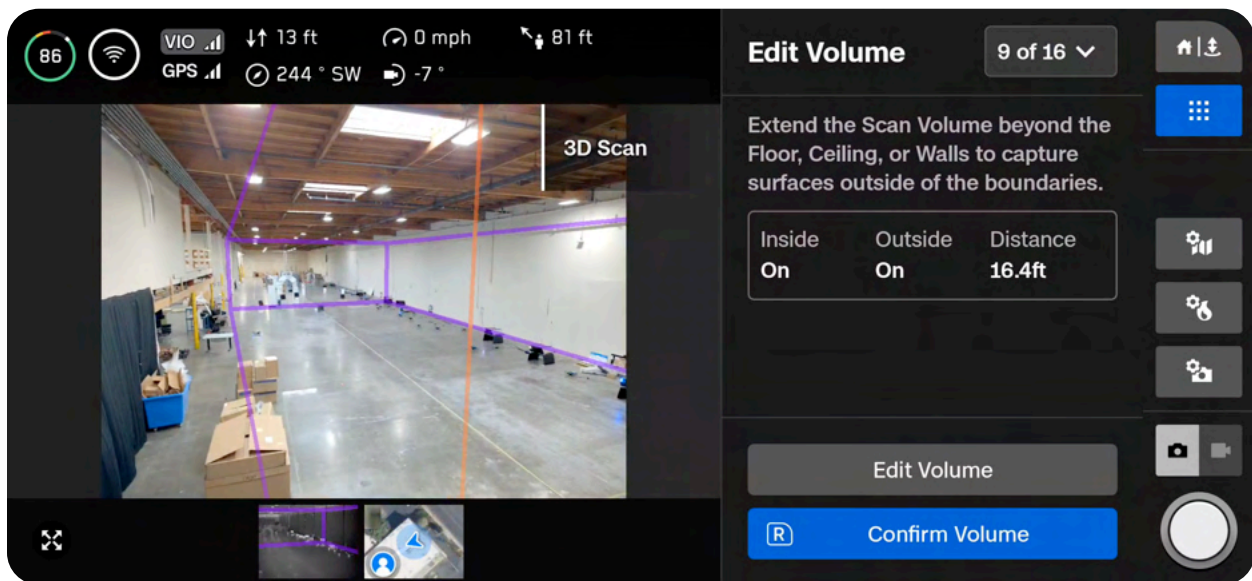

There are two options when extending the capture area:

Scan Inside Pillars captures everything that is located within the scan volume. Disabling this setting will exclude any structures within the scan volume.

Scan Outside Pillars enables the drone to scan the area surrounding the initial scan volume, effectively performing an “inside out” scan. You may choose to extend beyond any of the three boundaries: Ceiling, Floor or Walls.

By default, Skydio will scan both the **Inside Volume** and **Outside Volume**. All Strict Geofences are **ON** by default, meaning the drone will stay within the boundaries you set, but face outward to capture photos of the walls or ceiling.

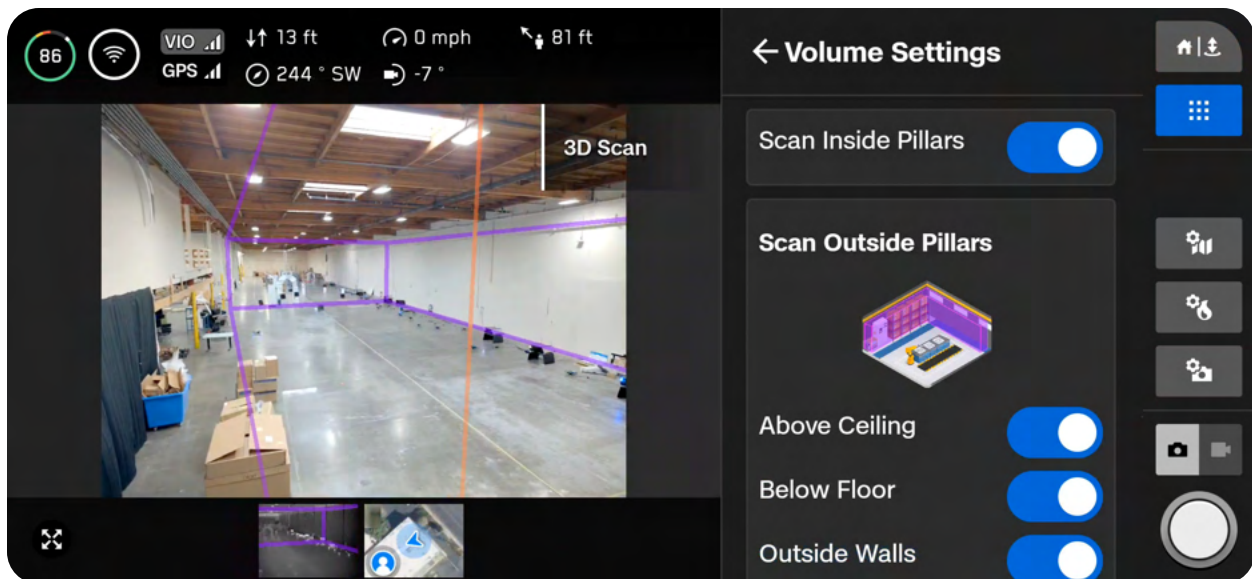

Step 10 - Strict Geofence

All three Strict Geofences are on by default in Indoor Capture.

Independently toggle the Ceiling, Floor, and Walls **ON** or **OFF** to set the geofence. By default, Skydio will remain within the scan distance of the boundaries.

Enabling a strict geofence (selecting **ON**) blocks flight outside of the scan volume along that bound. The drone will continue to enter and exit the scan volume through the same location.

- Skydio honors the Visual Geofence during the Explore phase and the scanning process, as well as when transitioning between the two. *Read more about the Visual Geofence in the 3D Capture Settings section.*
- You will also see a setting called **Safe Distance**, which allows you to set the distance from which Skydio will stay away from the structure while scanning. *Read more about this setting in the Visual Geofence or the 3D Capture Settings sections.*

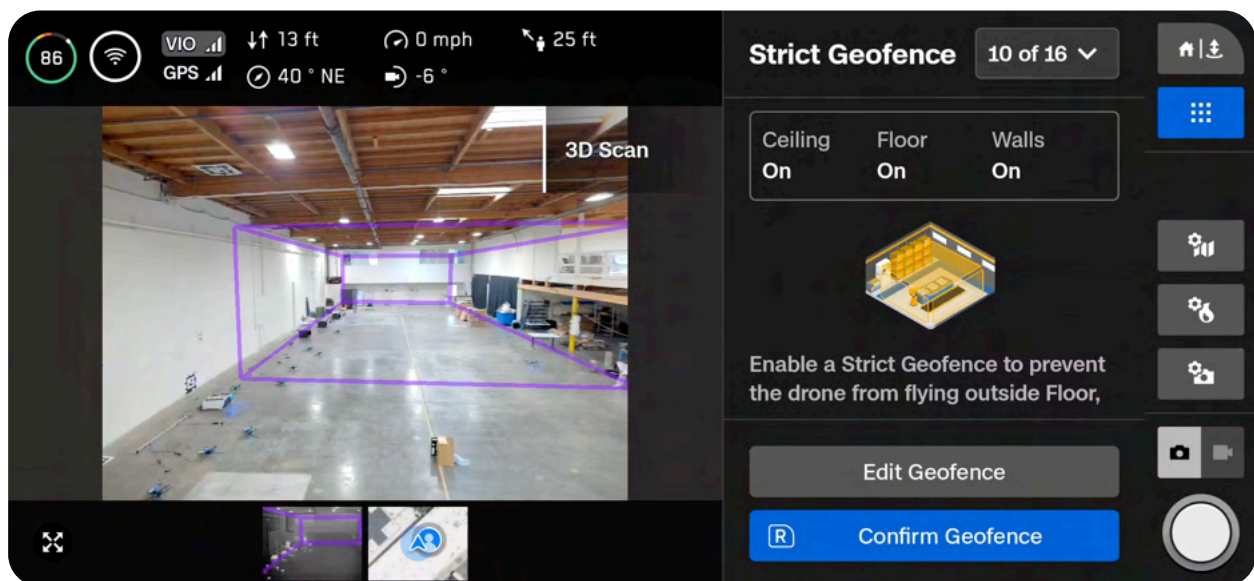

NOTE: Skydio will skip image capture locations that are located outside any of the toggled geofence boundaries. This may result in gaps in coverage.

Step 11 - Set AR Observer

The Augmented Reality (AR) Observer allows you to set the point of view from which you can observe an augmented-reality view of the scan progress.

- When you set your AR Observer point, the drone will take a static image from that position
- The AR drone will follow the white lines, which denote the planned flight path and image capture locations
- The purple AR lines show the Wall boundaries (pillars)

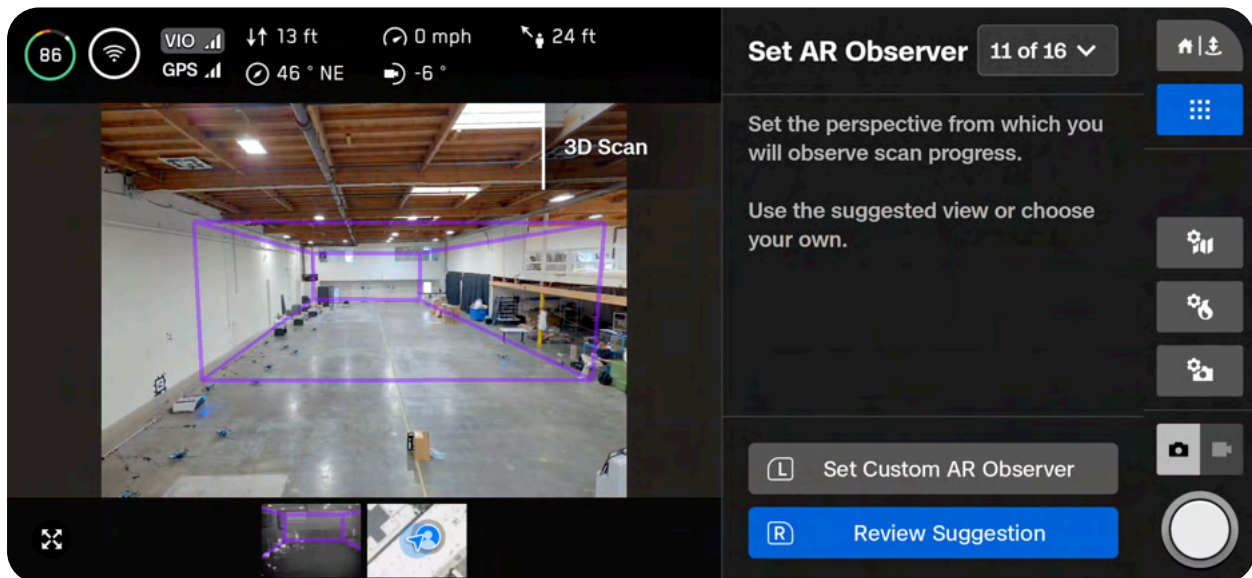

There are two options when setting the AR Observer:

Review Suggestion means Skydio will fly to the ceiling of the pillar closest to the launch position. The drone will then face the structure (the centroid of the AR polygon-prism).

Set Custom AR Observer allows you to manually pilot the drone to your preferred vantage point. If you choose to manually set the location of the AR Observer, ensure you are choosing a spot that provides you with the best situational awareness for monitoring the scan's progress.



NOTE: *The AR Observer is only available for the color camera.*

**Tips for manually setting the AR Observer:**

- Tightly frame the structure and fill the frame vertically or horizontally
- Select this option if you are scanning around obstacles or in complex environments

To view the AR Observer, select the **Picture-in-Picture (PIP)** button in the bottom left of the Flight Screen. You also have the option to set this as one of your views in the Single, Split, or Grid Display Layouts.

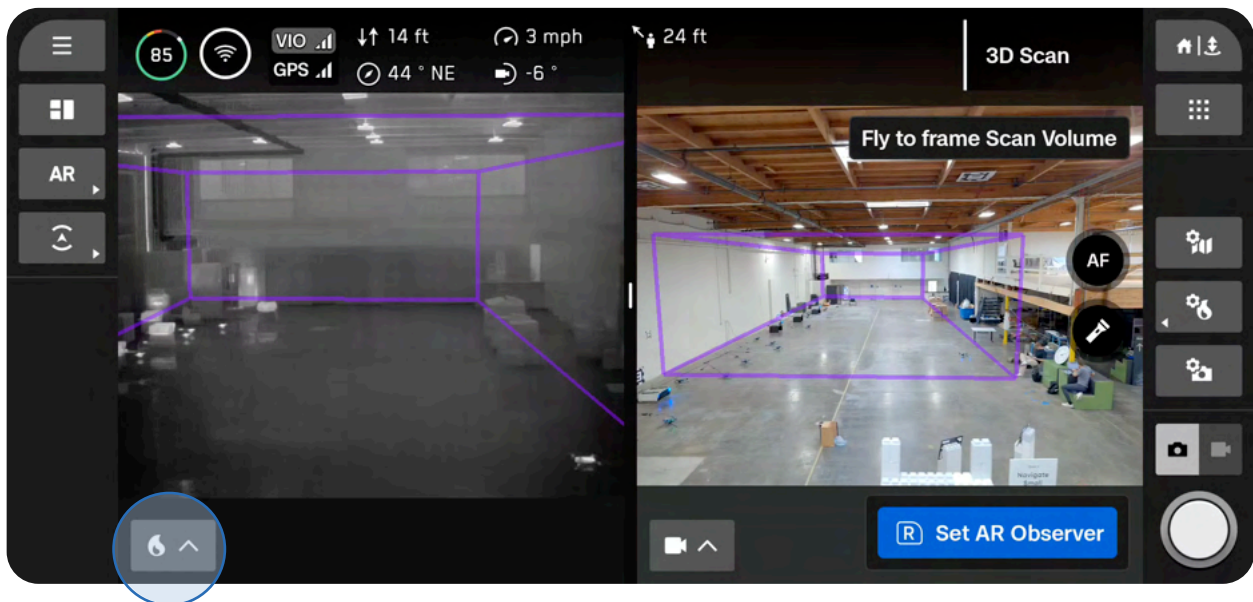

Step 12 - Exploration

The drone will briskly and autonomously fly around the scan volume to build an internal model of the structure being scanned.

Select **Edit Settings** to adjust the speed at which your drone completes the Explore Phase.

- Minimum speed: 1.1 mph (0.5 m/s)
- Maximum speed: 8 mph (3.5 m/s)
- Default speed: 8 mph (3.5 m/s)

You may also enable a **Strict Geofence** for this exploration phase.

Skydio uses this internal model to intelligently predict overall scan time and number of capture points needed to complete the scan. The explore phase should be a small fraction of the total scan time, and a rough time estimate is given.

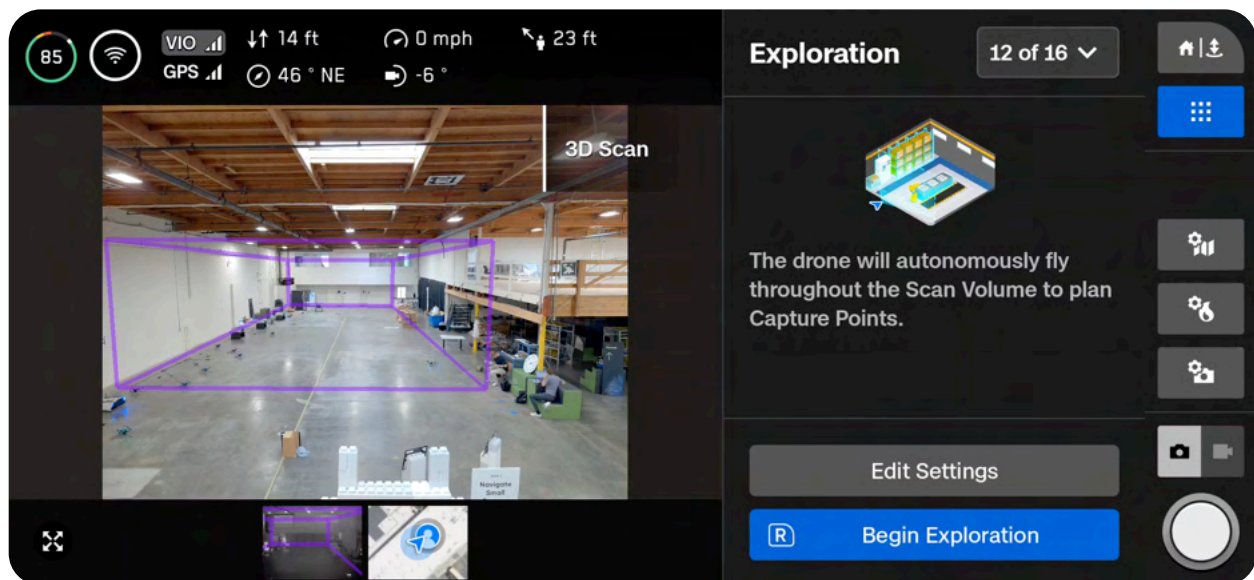

TIP: Use AR Quick Actions to toggle the AR Coverage Mesh. It may take a moment to load.

Step 13 - Scan Settings

View a summary of your scan settings, plus estimates for the total scan time, required number of batteries, and total number of photos. You must have at least five photos to begin a scan. Editing scan settings will impact the total flight time, number of photos and the required number of batteries.

Scan settings include:

- Distance to Surface
- Overlap and Sidelap
- Strict Geofence
- Maximum Speed
- Scan Passes (Z, Y, X)
- Maximum Speed
- Take Best Photo
- Stop for Photo
- Photo Settings (located in a separate menu)
- Field of View (VT300-L only)

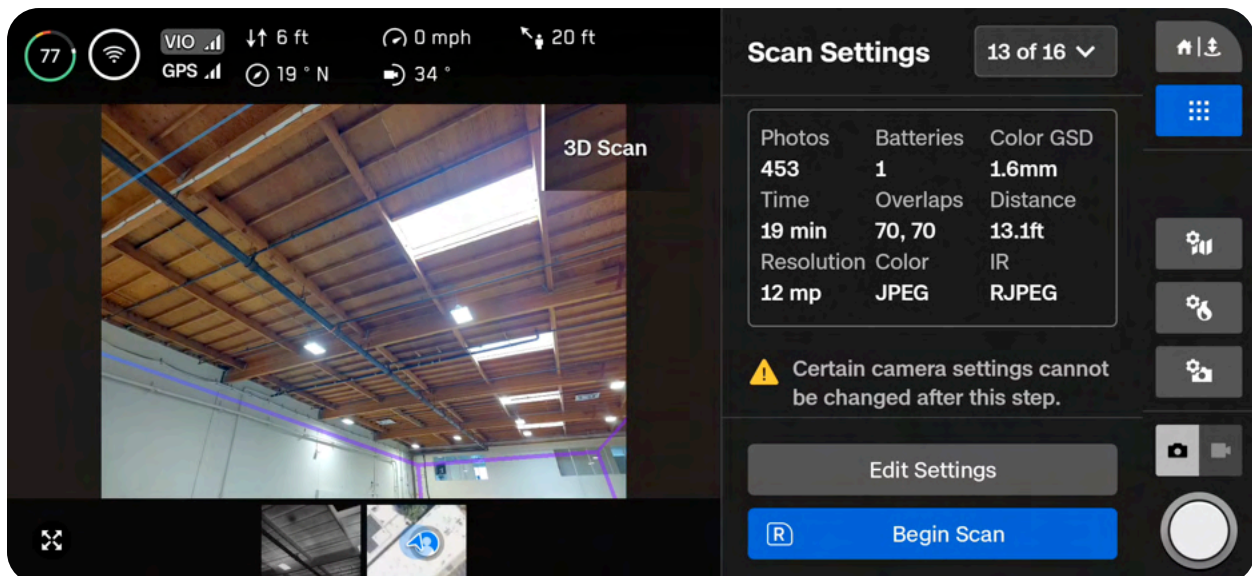
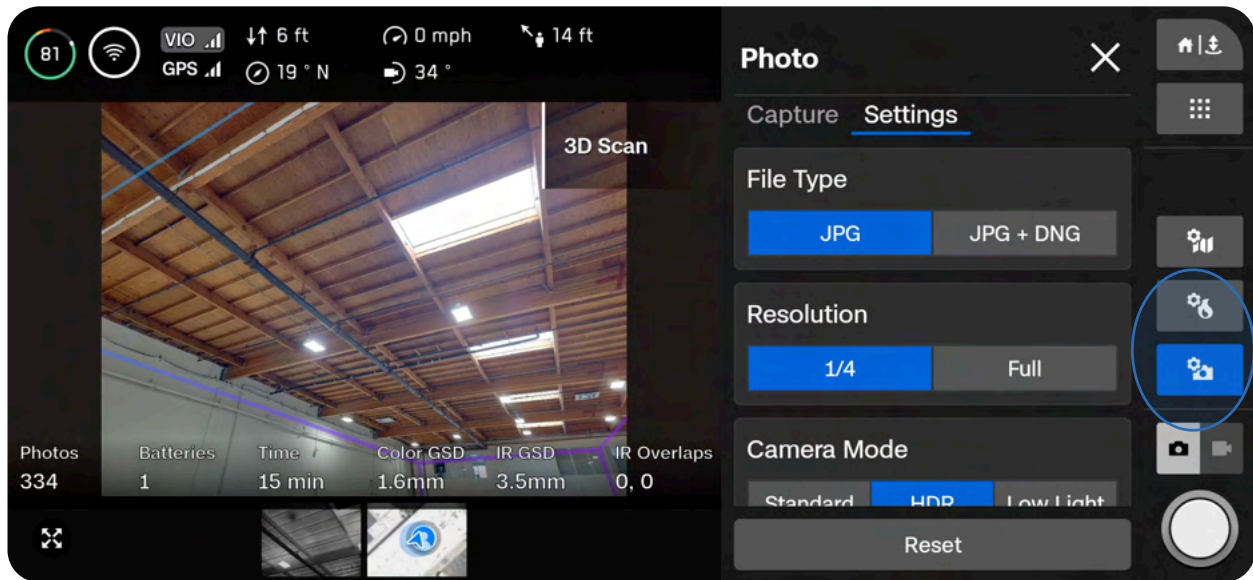

Photo Settings

You can also adjust your camera settings, including color and thermal camera settings, at this stage. Select the **Color or Thermal camera icons** on the right side of your screen to access your photo settings.

We recommend using **1/4 Resolution**, instead of Full, when scanning in dimly lit indoor environments.



After this step, you will not be able to adjust the following camera settings while scanning:

- Resolution (Full or 1/4)
- Camera Mode (Standard, HDR, Low Light)
- Enabling or disabling thermal JPG or RJPG files
- Enabling or disabling DNG files
- Changing Field of View: Wide vs Narrow (VT300-L only)

The thermal camera has a different Field of View (FOV) compared to the color (RGB) camera. Due to this, the **Overlap, Sidelap, and GSD (Distance to Surface slider)** values for the thermal camera and the color camera are different within the same scan. The values in the workflow pane on the right represent the color camera settings.

- You will see a summary of the thermal (IR) setting values displayed on the bottom of the live camera feed

If you are conducting a thermal scan and want a higher Overlap/Sidelap or GSD, increase these settings in the workflow pane until you reach your desired values.

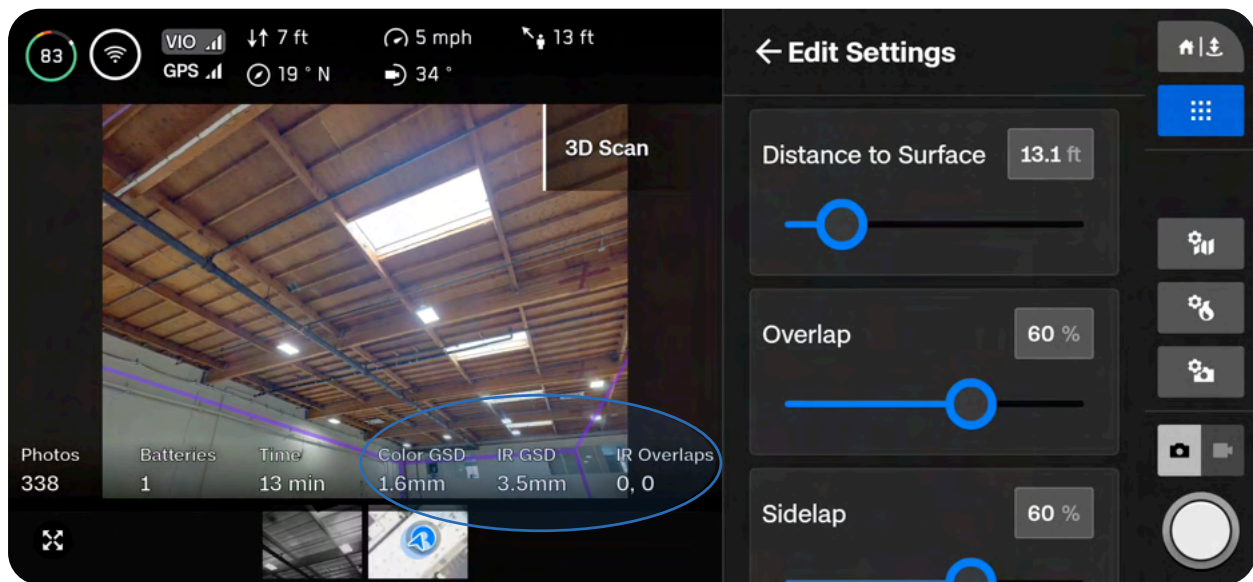

When reconstructing a thermal-only scan, we recommend at least 80/80 Overlap/Sidelap for the thermal sensor.

Intended thermal (IR) Overlap/Sidelap	Corresponding Color Overlap/Sidelap (Wide camera)	Corresponding Color Overlap/Sidelap (Narrow camera)
85/85	95/95	90/90
80/80	93/93	88/88
70/70	90/90	85/85

Use the **Maximum Speed** slider to set the maximum speed at which Skydio will travel while exploring, scanning and when returning to the Launch Point or Rally Point.

- Minimum speed: 1.1 mph (0.5 m/s)
- Maximum speed: 8 mph (3.5 m/s)
- Default speed: 8 mph (3.5 m/s)

Settings persist across scans of the same scan mode. Select the Reset button at the bottom of the list to restore settings to defaults.

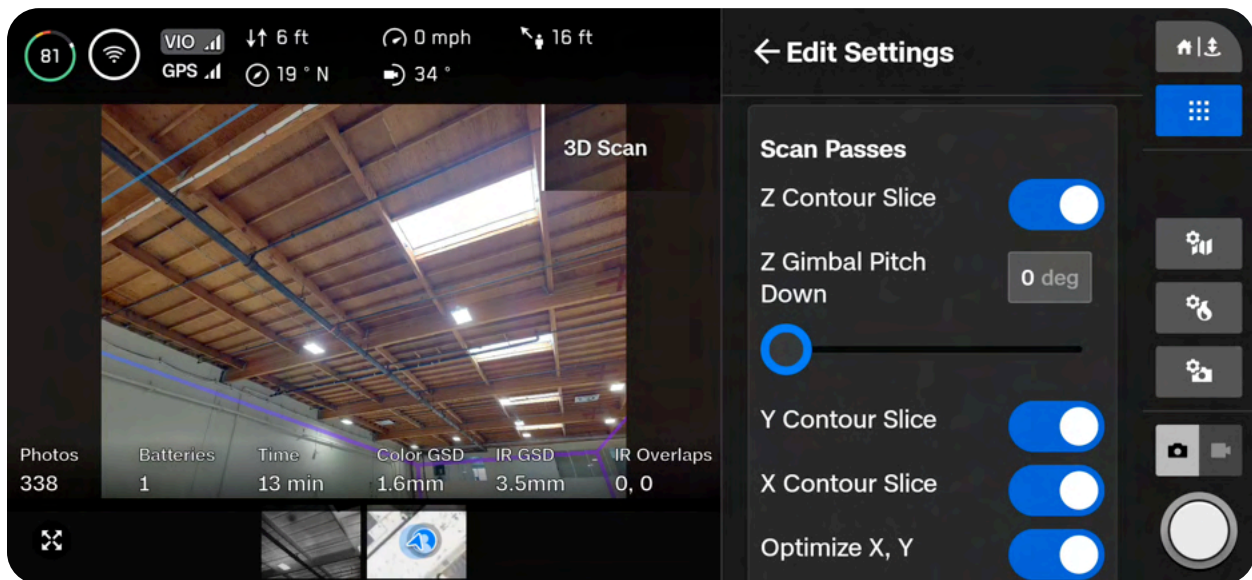

If you plan to process your thermal images in an external tool, you must enable RJPG files. Navigate to Thermal Camera > Settings and toggle on RJPG. This will ensure your drone captures radiometric JPG files.

You cannot capture thermal images by themselves. The following two file combinations are available:

- RGB files and Thermal JPG files
- RGB files and Thermal JPG + RJPG files
- If RJPG is enabled, you will also capture thermal JPG

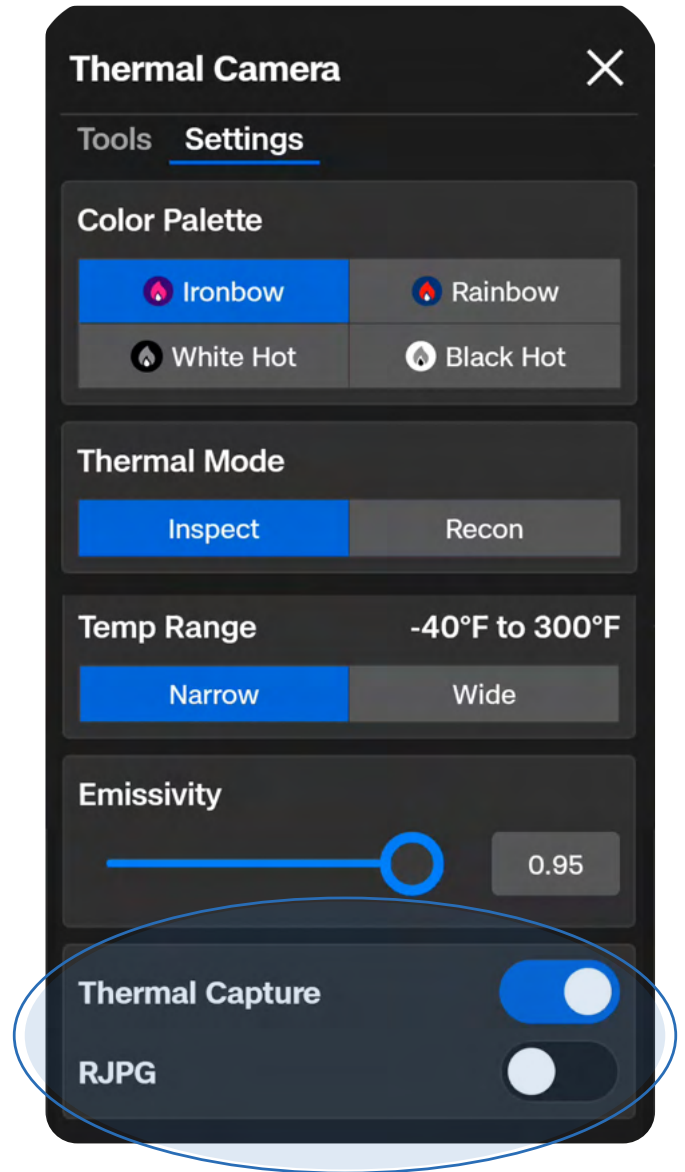

Once your settings are finalized, select **Begin Scan** and Skydio will begin autonomously scanning the structure.

Step 14 - Scan

You will see AR markers showing the scan capture points on the live camera feed.



Optionally toggle on the AR Coverage Mesh during your scan to monitor the photo coverage progress of the scan. *Learn more about this feature in the AR Coverage Mesh section.*



Pause at any point during your scan. Use the left shoulder button or tap this icon in the workflow pane to pause scanning. Skydio will display how many photos have been captured. While paused, you have the option to manually capture photos using the right shoulder button.



Press the play icon or use the left shoulder button to resume autonomous scanning. Use the right shoulder button during a scan to Skip to the next capture point.

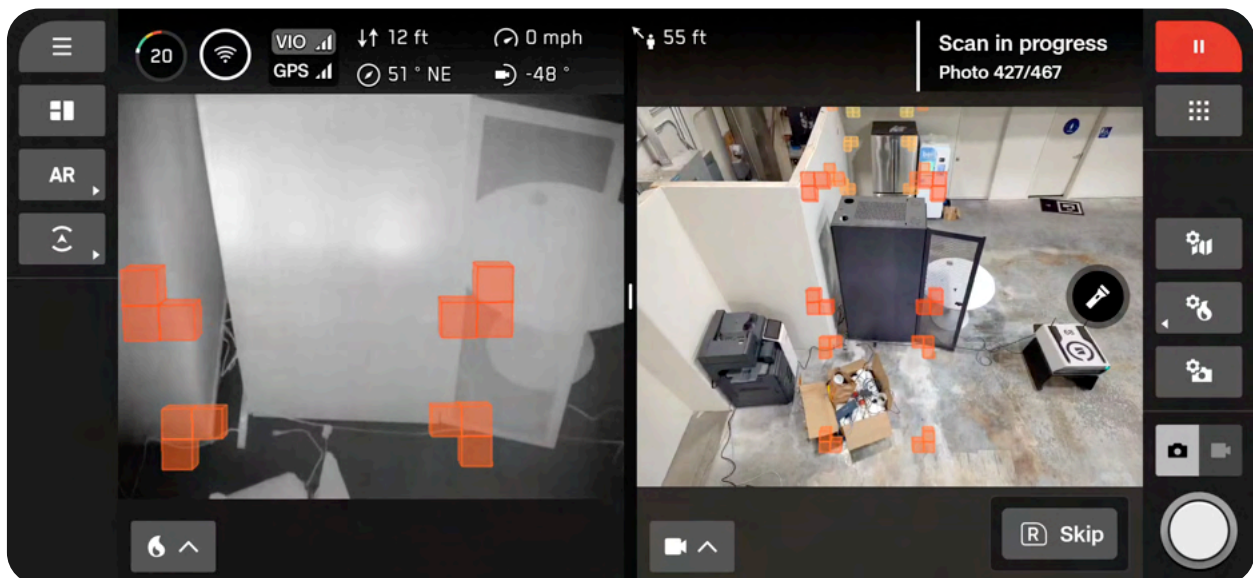

Your scan may require using several batteries to complete. *For information about how to scan with multiple batteries, read the [Scanning with Multiple Batteries](#) section.*



NOTE: *Even if Stop for Photo is disabled, you may see the drone pause, along with a “Saving Photos” notification. This is to ensure the SD card finishes writing the data. Autonomous scanning will resume automatically.*

Step 15 - Manual Photos (optional)

Once your scan completes, you have the option to manually capture additional photos of the scene or specific areas of interest.

The purple AR outline on-screen shows the Wall Bounds. Use the right shoulder button to take a photo.

- Manual photos appear in the scan folder and in the Model Viewer alongside photos captured autonomously

Obstacle Avoidance is set to Standard—and cannot be changed—when Skydio flies autonomously.

- If you are manually piloting the drone, you have the option to adjust your obstacle avoidance setting in the Quick Actions menu

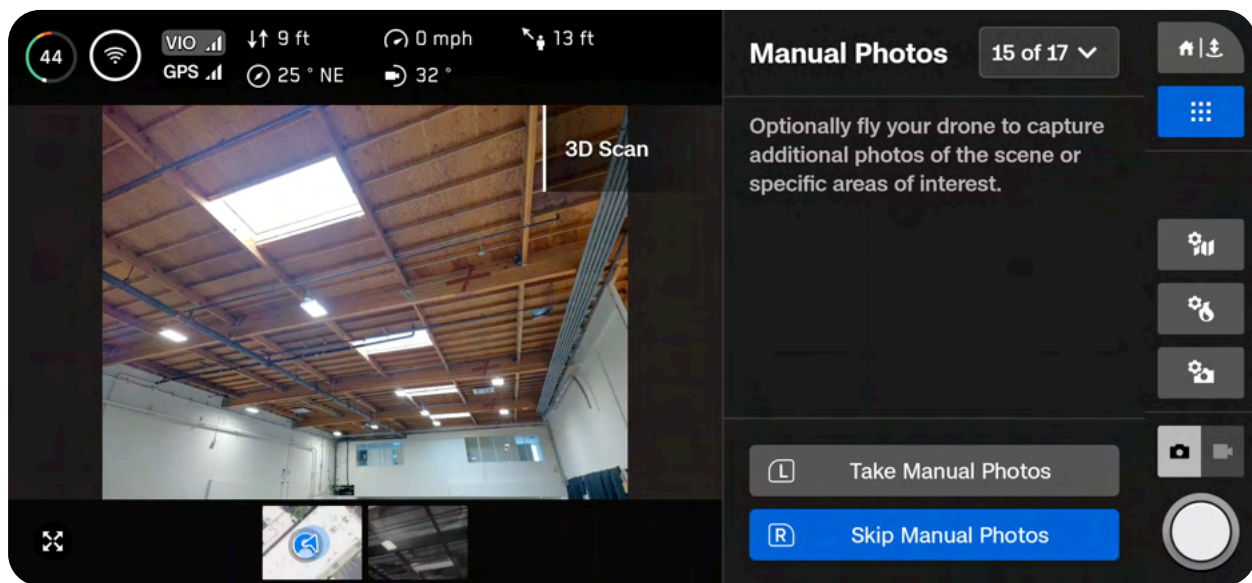

NOTE: Manual photos may be captured at any time by pressing pause. You may also optionally enable interval mode to have the drone take photos at different time intervals (ex: capture a photo every 5 seconds).



CAUTION: Skydio obstacle avoidance does not detect moving objects and is disabled during landing. Review the [Skydio Safety and Operating Guide](#) for more information.

Step 16 - Scan Complete

Once your scan completes, you have the option to either start a **New Scan** or **Return to Launch/Rally Point**.

Starting a new scan will prompt you with an option to save or discard the scan you just completed.

- If you Return to Launch and the path is clear, X10 will obey the geofence and fly in a straight path
- If X10 cannot find that path due to obstacles, you will be able to take control and manually pilot your drone

After landing, you will see a summary of the most recent scan and the option to **Save** or **Discard** the scan you completed.

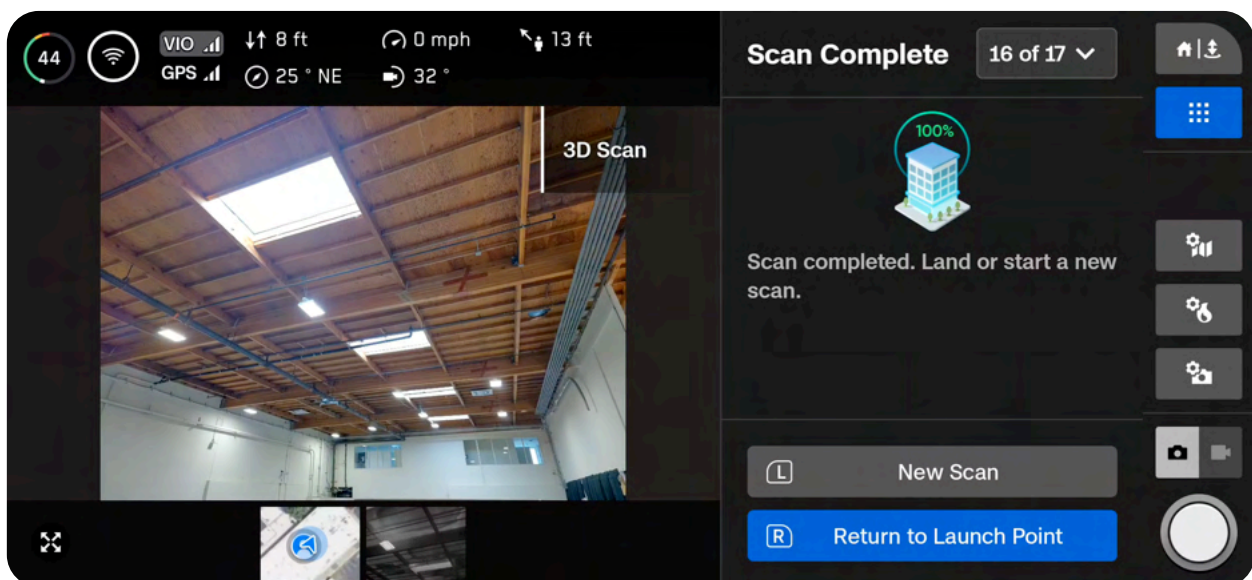

Step 17 - Post-processing

After saving your scan, you will have the option to create a textured model. This model is created onboard the drone and takes several minutes to complete.

If you select **No**, you will still need to wait a few minutes for the drone to process your scan. This is an important step to ensure your media is grouped by scan and saved properly.

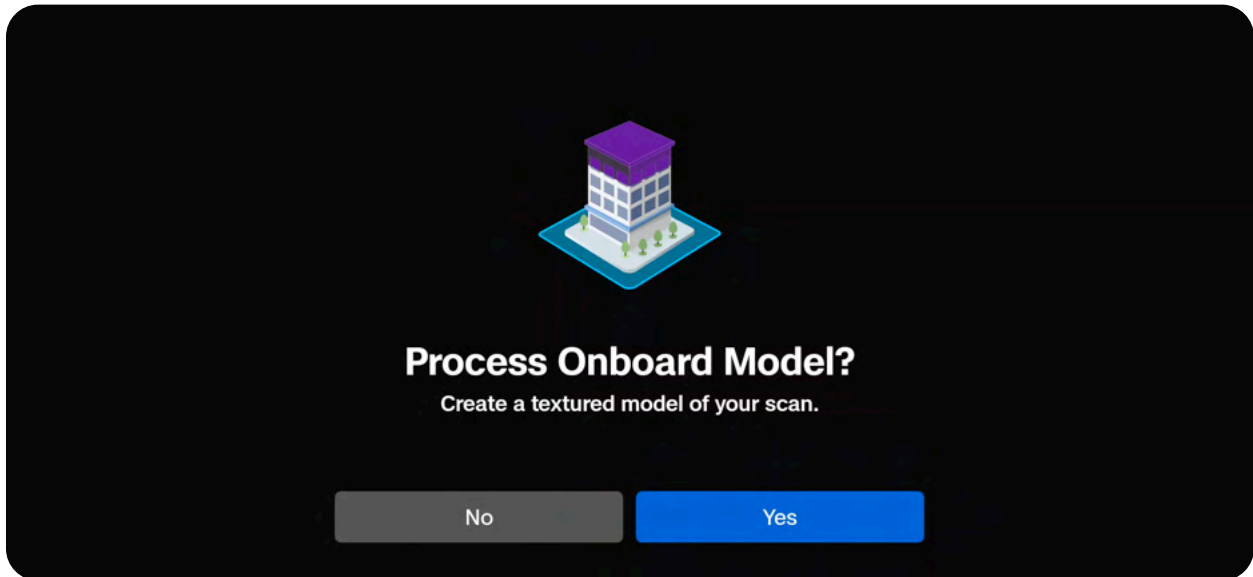

NOTE: If you do not generate an Onboard Model at this point, you will still have the option to generate one at a later time. For multi-battery scans, select **Yes** to generate an Onboard Model **after all flights are completed**.

If you select **Yes**, your drone will first process your scan and then the Onboard Model.

- Onboard Model creation uses HD thumbnails (1920x1440) and processes about 30 images per minute
- Model generation may take longer for larger scans (1000+ images)
- If the battery is low and you are processing a large model, ensure the drone is plugged into a power source

Once processing is complete select **Exit** to return to the Gate Screen or **Review Scan** to enter the Onboard Model Viewer.

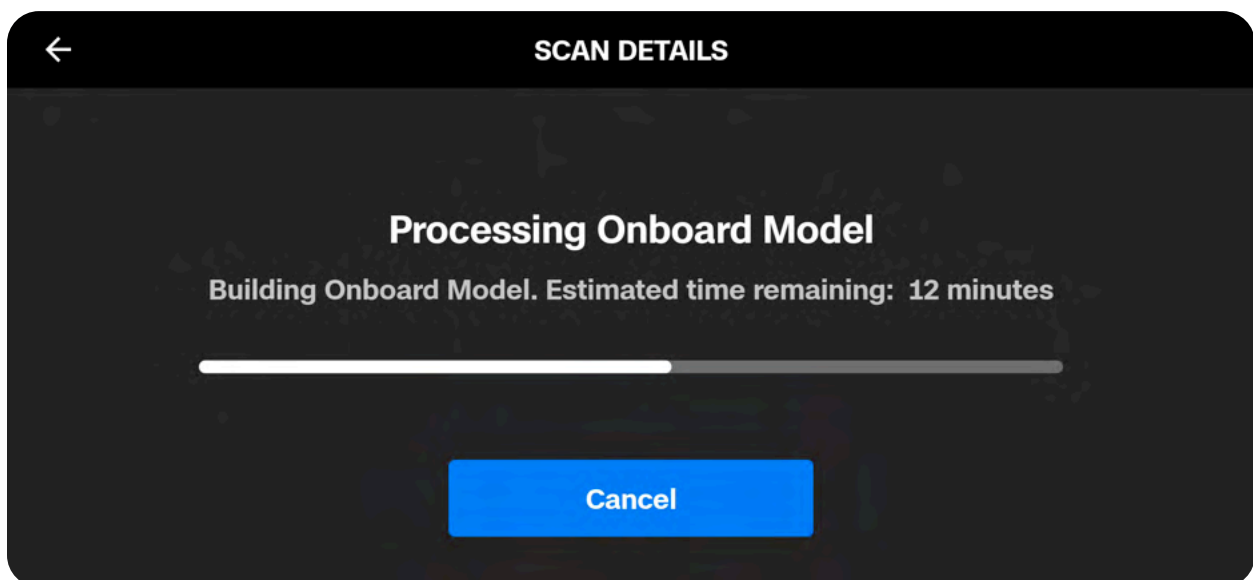

CAUTION: Do not remove the battery or power off during postflight processing. Doing so will result in loss of data. Do not power off or disconnect from the drone until processing is complete.



Multi-Battery Scans

Skydio X10 can resume scans across multiple battery changes without reliance on GPS. Review this section for steps on how to properly switch batteries.

This section covers

How to Change Batteries Mid-Scan

Overview

Using computer vision, Skydio can resume scans across multiple battery changes without reliance on GPS.

We recommend flying scans that require **no more than 4 batteries**. During the Review Scan Settings step, you will see a scan summary which includes the total scan time and estimated number of batteries. If your total number of batteries is greater than four, consider adjusting your settings or split the volume into separate scans.



CAUTION: Ensure you have enough battery to complete the Exploration step and begin scanning. You will only be able to save the progress of a scan once scanning begins. If your battery dies before scanning begins, you will need to restart the scan setup after replacing the battery.

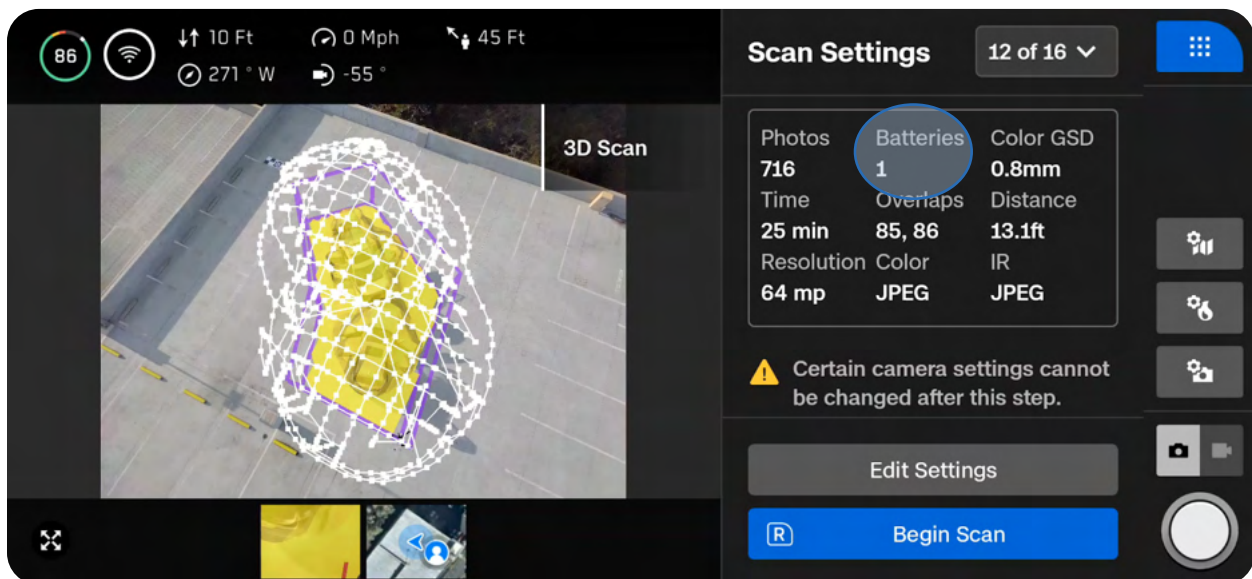

CAUTION: Wait to remove the depleted battery until all post-flight tasks are complete. Do not remove or swap out the Logs Card or Media Card between flights of the same scan. Removing either card when replacing a depleted battery will result in your drone being unable to resume the scan.

How to Change Batteries Mid-Scan

To successfully resume a scan after replacing the battery, **the drone must launch from the exact same position and orientation between each flight.** Taking off in a different location or orientation will result in errors when attempting to resume your scan. **We strongly recommend using a landing pad or marking your launch location and orientation.**

When the battery has about 10-15% charge (or 3 minutes of flight time) remaining, your drone will follow **Low Battery procedures.** You will have the option to Take Control to reposition your drone for landing.

Launch Position

Placed on a stable surface, straight, facing forward



After Battery Replacement

Do not place the drone askew or in a different location from where you launched in the previous flight



When the battery has about 10-15% charge (or 3 minutes of flight time) remaining, your drone will follow **Low Battery procedures**. You will have the option to Take Control to reposition your drone for landing.

To change batteries mid-scan:

Step 1 - Land and save your current scan

After saving your scan, you will see a screen asking if you would like to process an onboard model. If you intend to create an onboard model, you only have to select **Yes** once the final flight has completed.

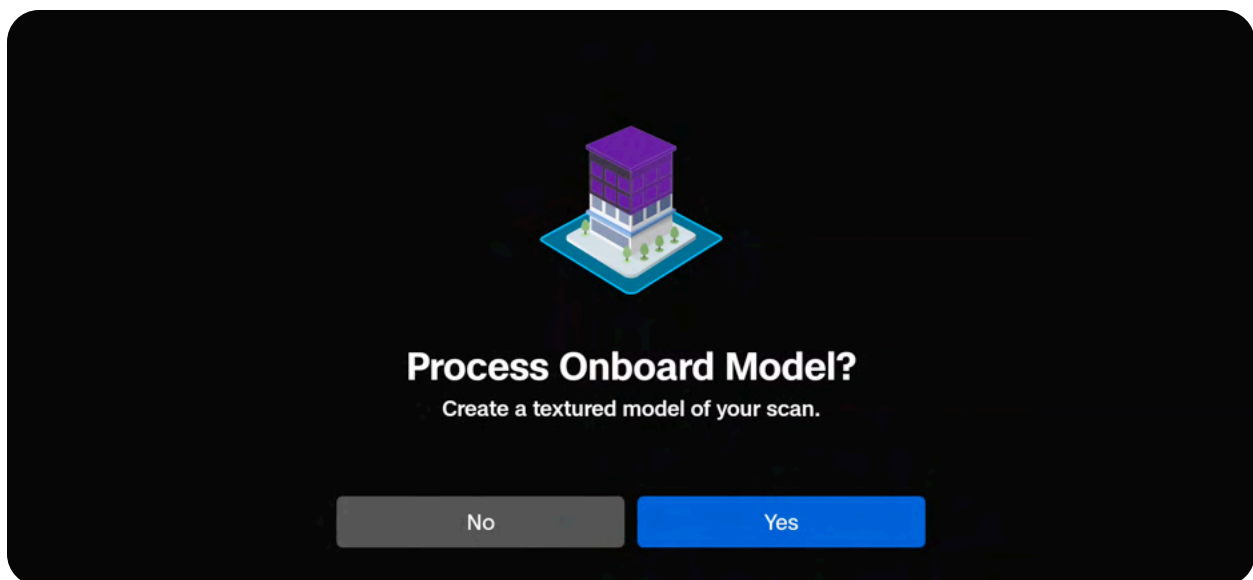
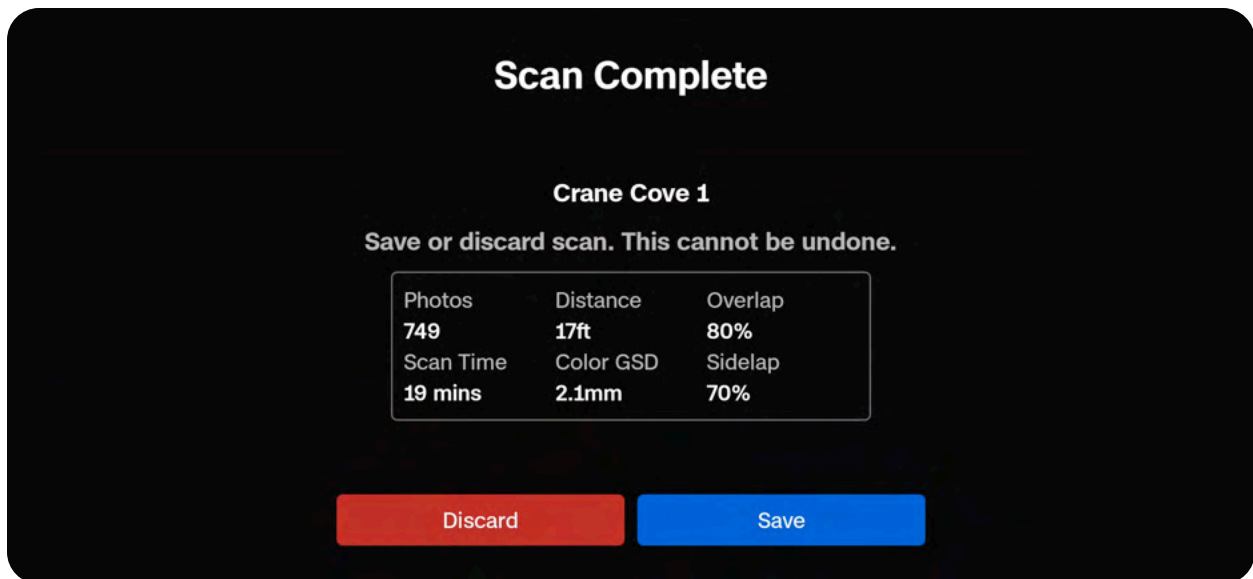

Step 2 - Wait as post-flight processing completes



CAUTION: Do not remove the Media Card or the Logs Card between flights of the same scan. Removing either card when replacing a depleted battery will result in your drone being unable to resume the scan. Do not power off until all post-flight processing is complete.

Step 3 - Power off your drone, remove the depleted battery and replace

Step 4 - Once the fully charged battery is inserted, power on your drone

Step 5 - Launch from the exact same position and orientation

After replacing the battery, launch to begin your flight. You should see an option to either continue the scan or begin a new one. Select **Continue** when prompted to resume.

The drone must launch from the exact same position and orientation between each flight. Taking off in a different location or orientation will result in errors when attempting to resume your scan.



NOTE: *The landing position and orientation does not matter.*

Return Behaviors with Geofences Enabled

3D Capture or Indoor Capture

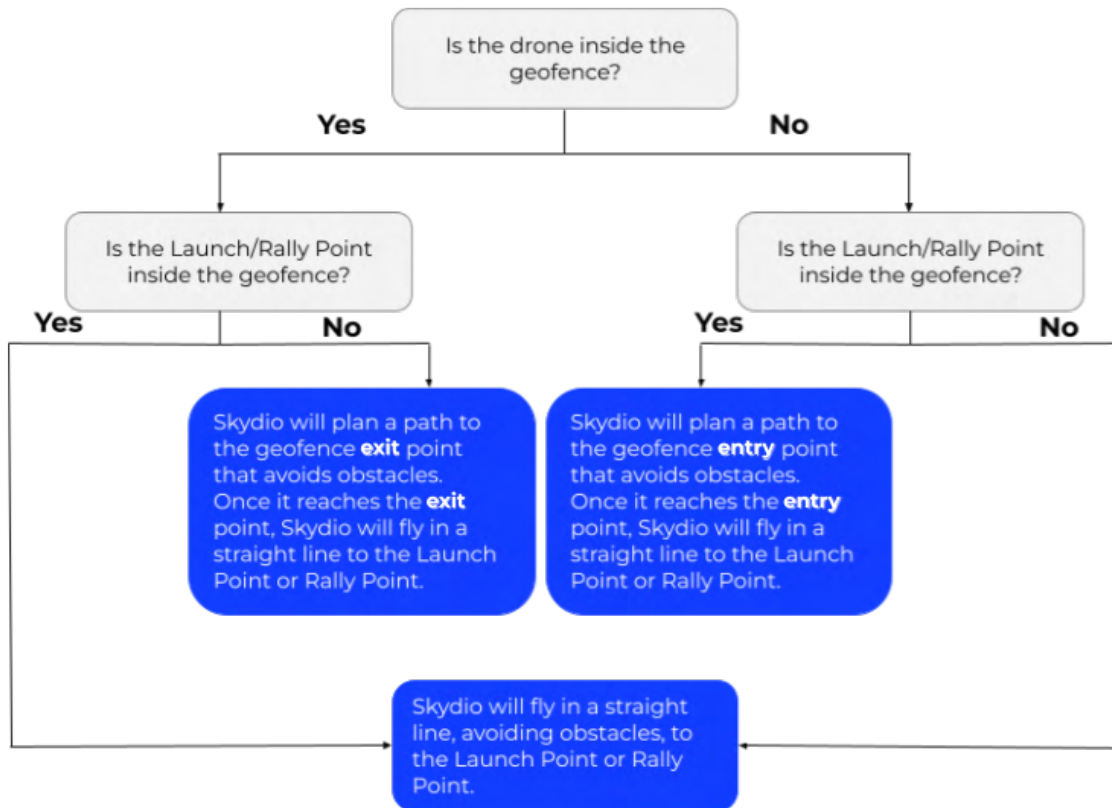

When completing a Surface Capture with geofences enabled:

If both your drone and the Launch/Rally Point are inside the geofence, Skydio X10 will maintain the same altitude as the scan Height and fly in a straight line to the Launch/Rally Point. Once it reaches either location, it will descend and hover above the point.

If either the drone or the Launch/Rally Point is located outside the geofence, X10 will plan a path to the geofence entry or exit point then fly at the same altitude as the scan Height to the Launch/Rally Point. Once it reaches either location, it will descend and hover above the point.



NOTE: The geofence entry or exit path is defined as the location on the geofence that is closest to the Launch Point or Rally Point location.



Onboard Modeling

Onboard Modeling with Skydio X10 features a fully end-to-end workflow that enables you to build a 3D model (Onboard Model) or 2D map (Onboard Map) immediately after your scan.

This section covers

Using the Model Viewer

Creating Onboard Models

Model Viewer Tools

Exporting Onboard Maps or Models

Using the Model Viewer

Use the Model Viewer to browse through scan photos, review a coverage mesh of your scan, and preview Onboard Maps or Models of your scan to validate data before leaving the scan site. Access this using Skydio Flight Deck.

- All scan modes include the option to generate a Textured 3D Model, or **Onboard Model** (.gLTF file)
- For Surface Capture, an additional Orthorectified 2D Map, or **Onboard Map**, is automatically generated (.tiff file)

Accessing and Navigating the Model Viewer

To open the Model Viewer within Skydio Flight Deck, simply select **Review Scan** after completing a scan.

You can also open the **Media** menu, select the thumbnail of a scan you'd like to view, and the Model Viewer will automatically open with the scan loaded.

Once the scan loads, you will see three separate tabs at the bottom of your screen.

- **Model (default)** - previews a 3D reconstruction of your structure or area. Use this option to view generated Onboard Maps/Models.
- **Image** - displays the individual images associated with a selected capture point.
- **Gallery** - displays the collection of images taken during the scan.

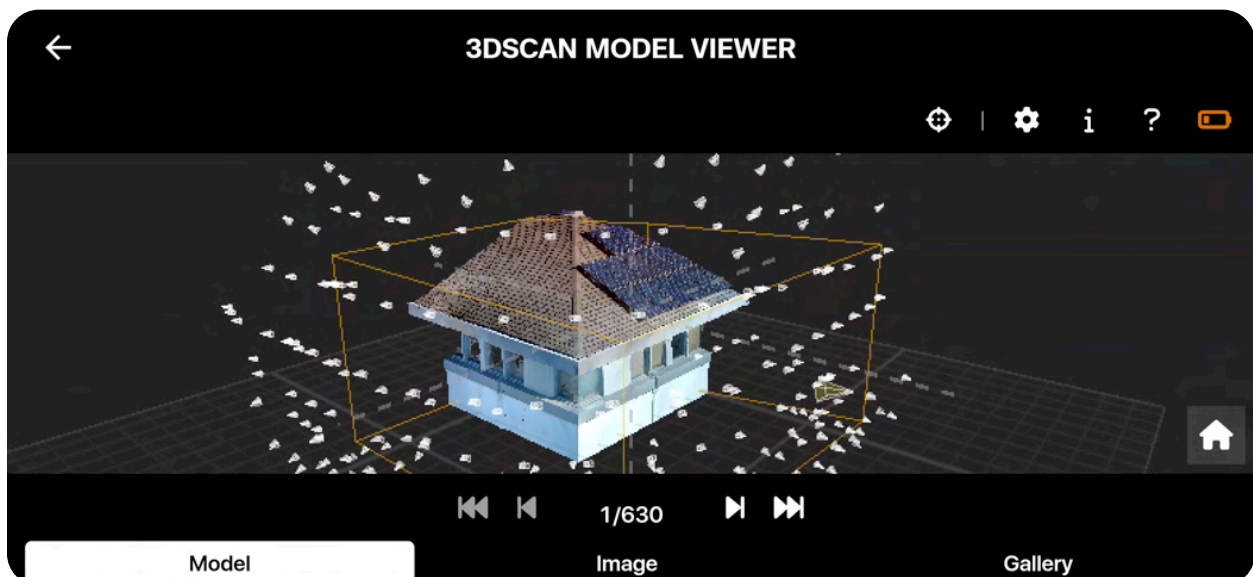

Creating Onboard Models

There are two ways to create onboard maps/models after a scan:

- Immediately after a scan using Flight Deck
- Using the Media menu



CAUTION: Do not power off or remove the battery while processing. Doing so will result in the loss of data.



NOTE: Onboard Modeling is not available with thermal images.

Using Flight Deck

Step 1 - Perform a scan

Select **Save** after the scan completes.

Scan Complete

3D Capture

Save or discard scan. This cannot be undone.

Photos	Distance	Overlap
320	24.8ft	80%
Scan Time	Color GSD	Sidelap
22 mins	0.6mm	70%

Discard **Save**

Step 2 - Select Yes

When asked if you would like to process an onboard model, select **Yes** to begin generating.

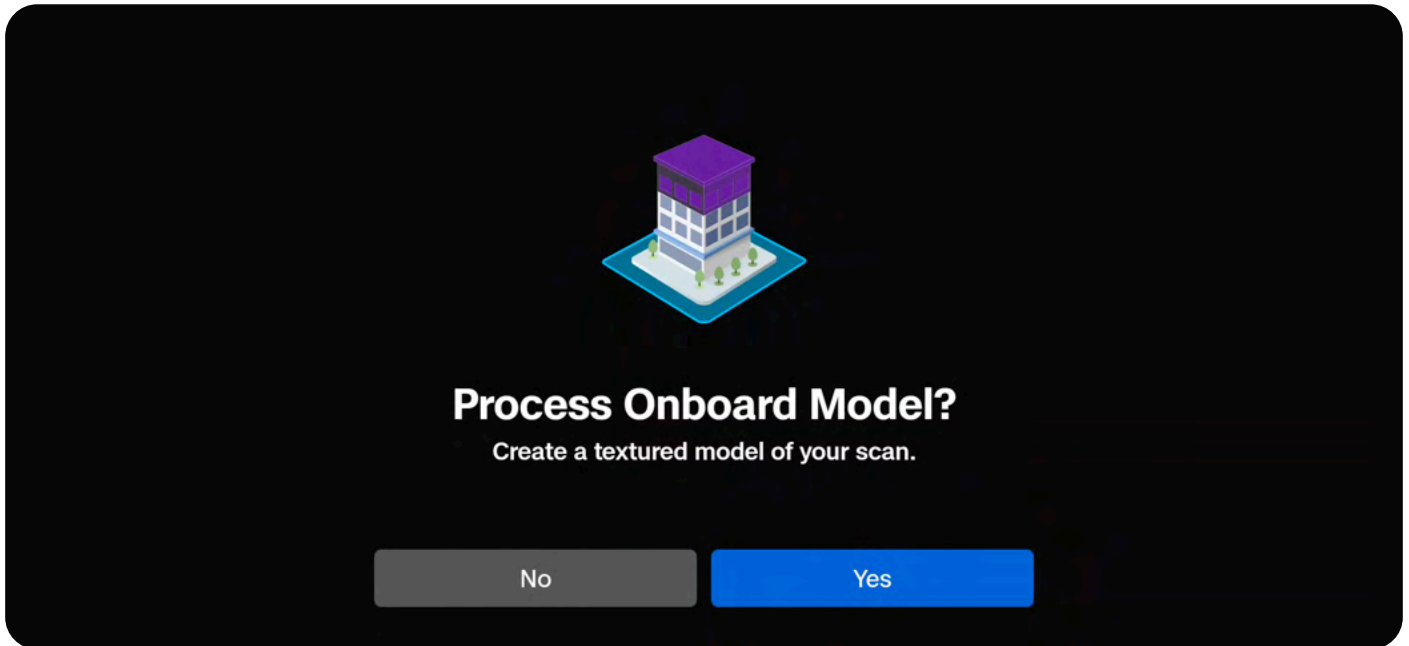

Step 3 - Wait for your model to generate

Your scan will process first, followed by the Onboard Model. Onboard Map/Model creation uses HD thumbnails (1920x1440) and processes about 30 images per minute.

- Model generation may take longer for larger scans (1000+ images)



If the battery is low and you are processing a large model, ensure the drone is plugged into a power source.

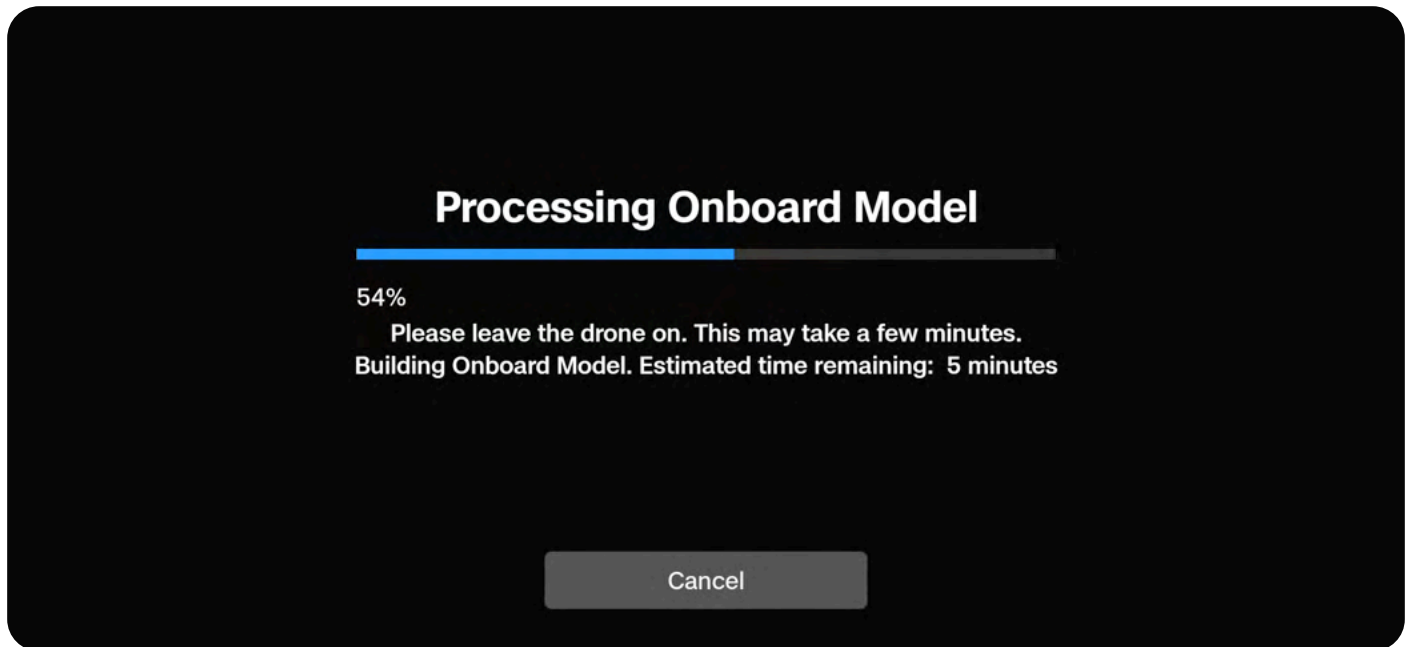

Step 4 - View your model

Select **Review Scan** to enter the Model Viewer. You can also view your scan at any point using the **Media** menu.

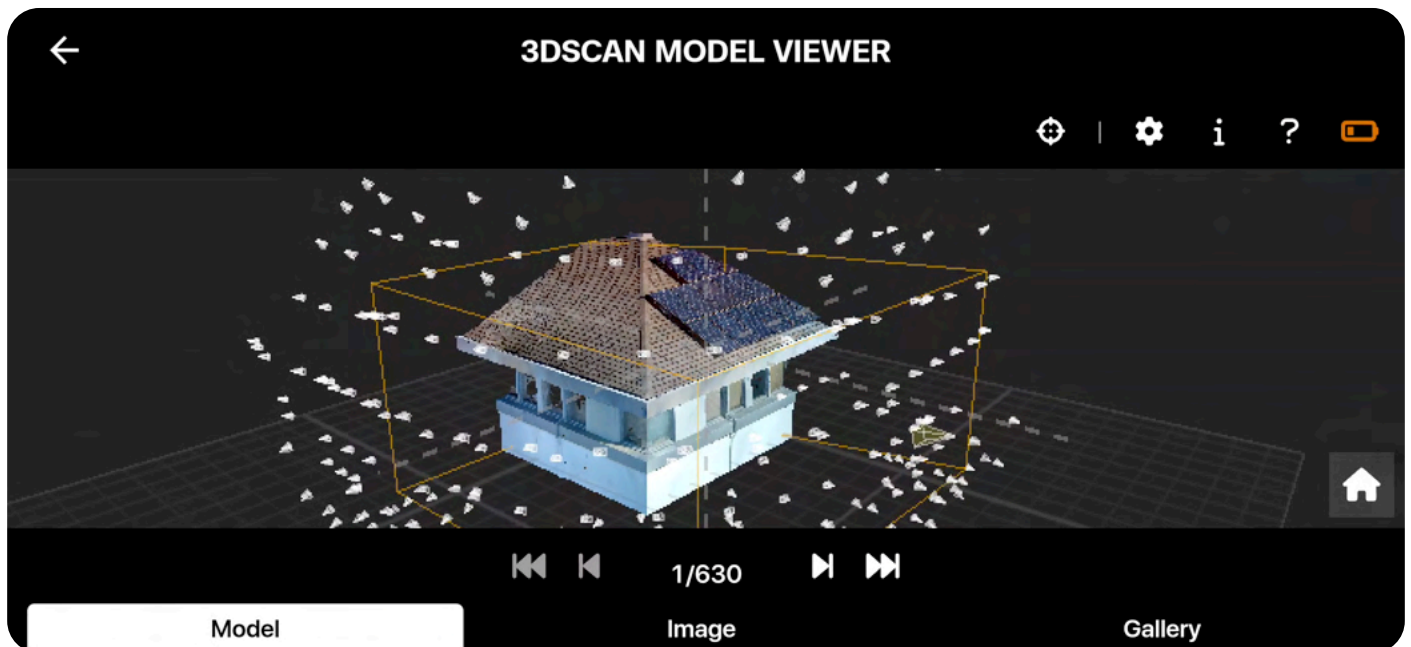
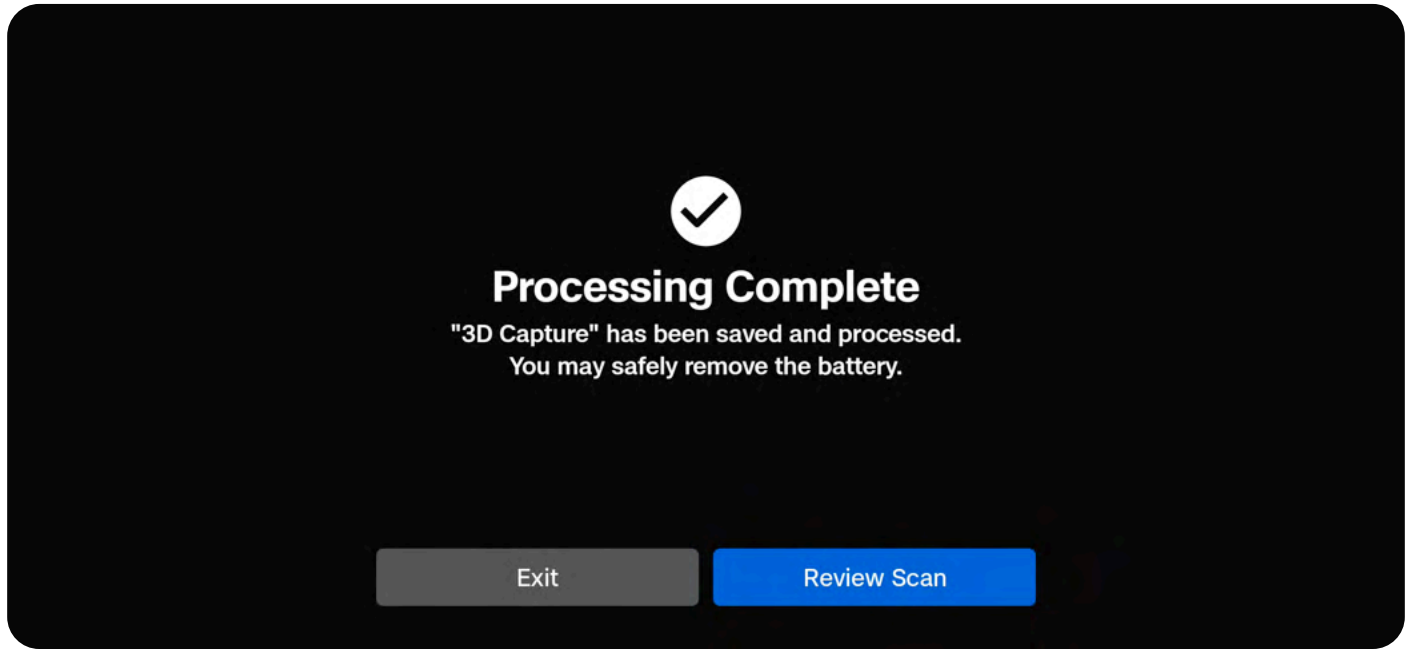

Using the Media Menu

Step 1 - Navigate to the Media menu

Open Global Settings and select Media.

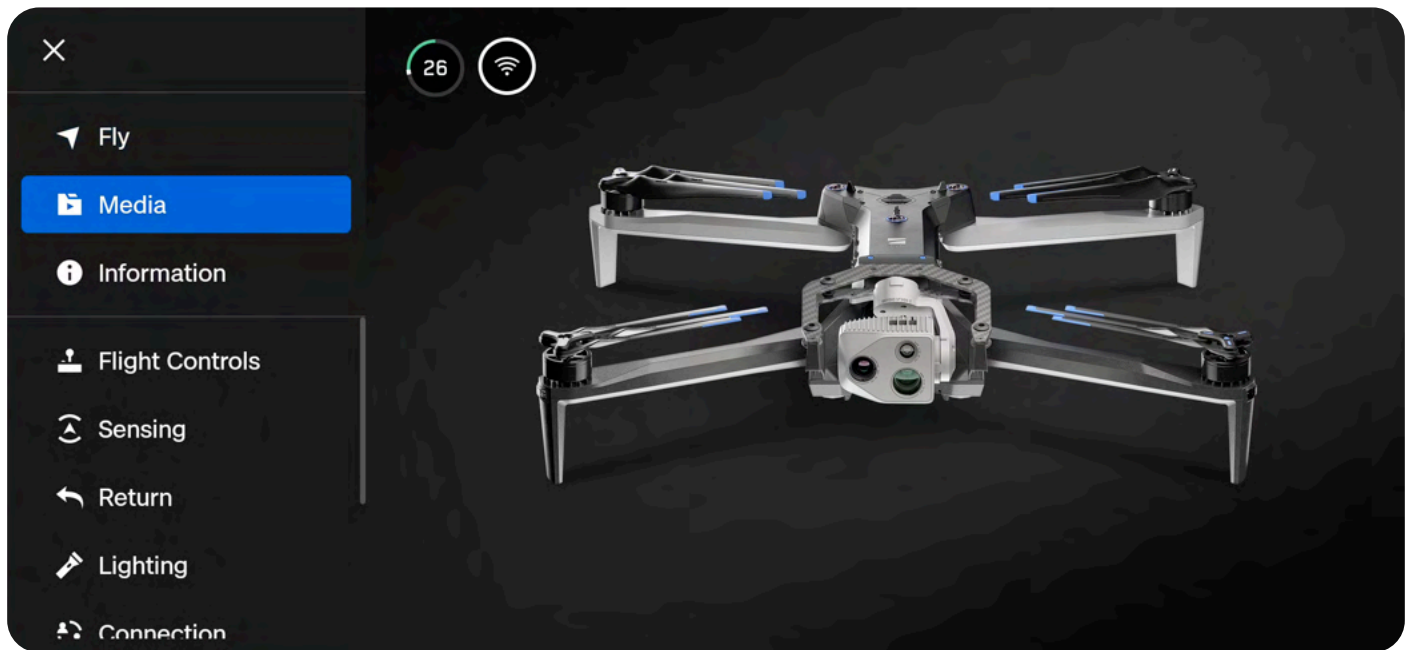

Step 2 - Select a scan

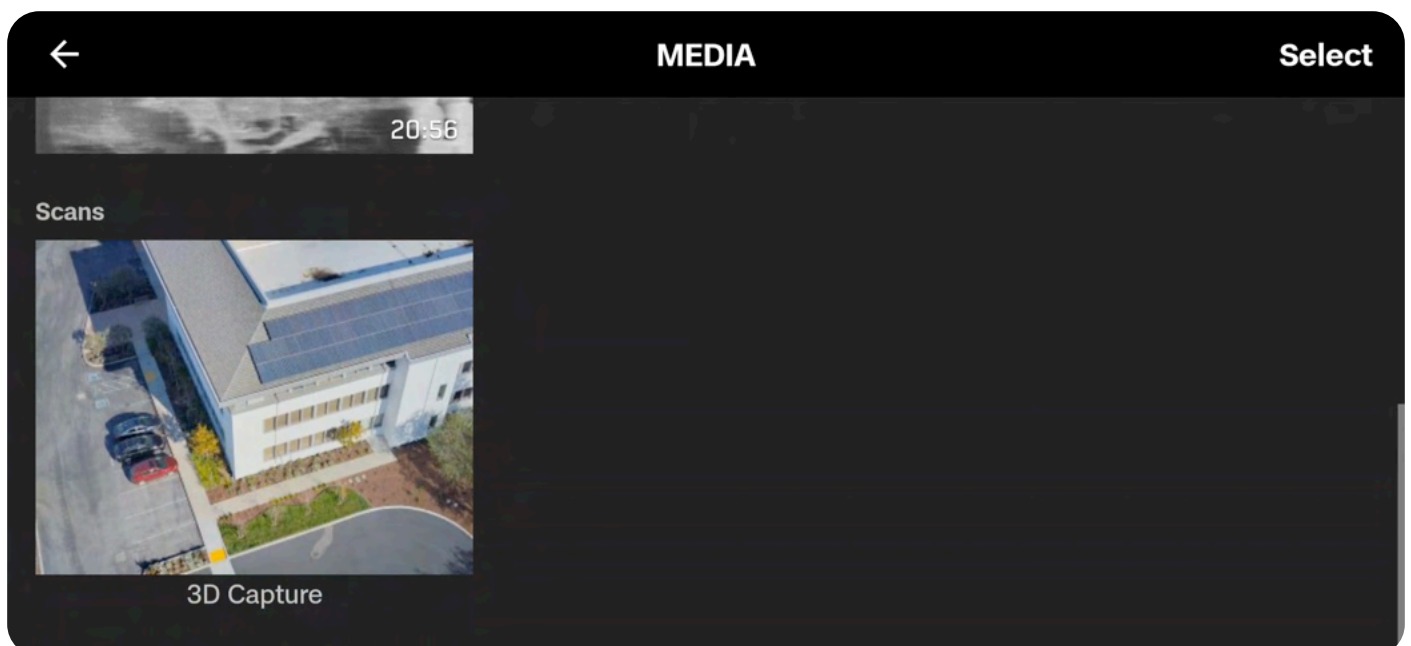

Step 3 - Select Create Model

← **SCAN DETAILS**



PHOTOS	DISTANCE	OVERLAP
320	24.8 ft	80%
SCAN TIME	GSD	SIDELAP
20 mins	0.024 in	70%

3D Capture
3D Capture
Dec 4, 2023 1:32:34 PM

Create Model

Review Scan

Step 4 - Wait for your model to generate

Your scan will process first, followed by the Onboard Model. Onboard Map/Model creation uses HD thumbnails (1920x1440) and processes about 30 images per minute.

- Model generation may take longer for larger scans (1000+ images)

If the battery is low and you are processing a large model, ensure the drone is plugged into a power source.

Processing Onboard Model

54%

Please leave the drone on. This may take a few minutes.
Building Onboard Model. Estimated time remaining: 5 minutes

Cancel

Model Viewer Tools

Zoom in and out by pinching with two fingers. Drag to navigate around the model. Use the arrows at the bottom of the screen to navigate through individual images and capture points on the model.

- Any time the active thumbnail changes, the image gallery will update to that view
- Select the Help menu for a breakdown of navigation controls

Coverage Heatmap

Indicates the number of images taken at each location

- The photo count in the bottom left defines the coverage mesh colors in relation to the number of photos taken
- Yellow indicates minimal coverage
- Purple indicates full coverage

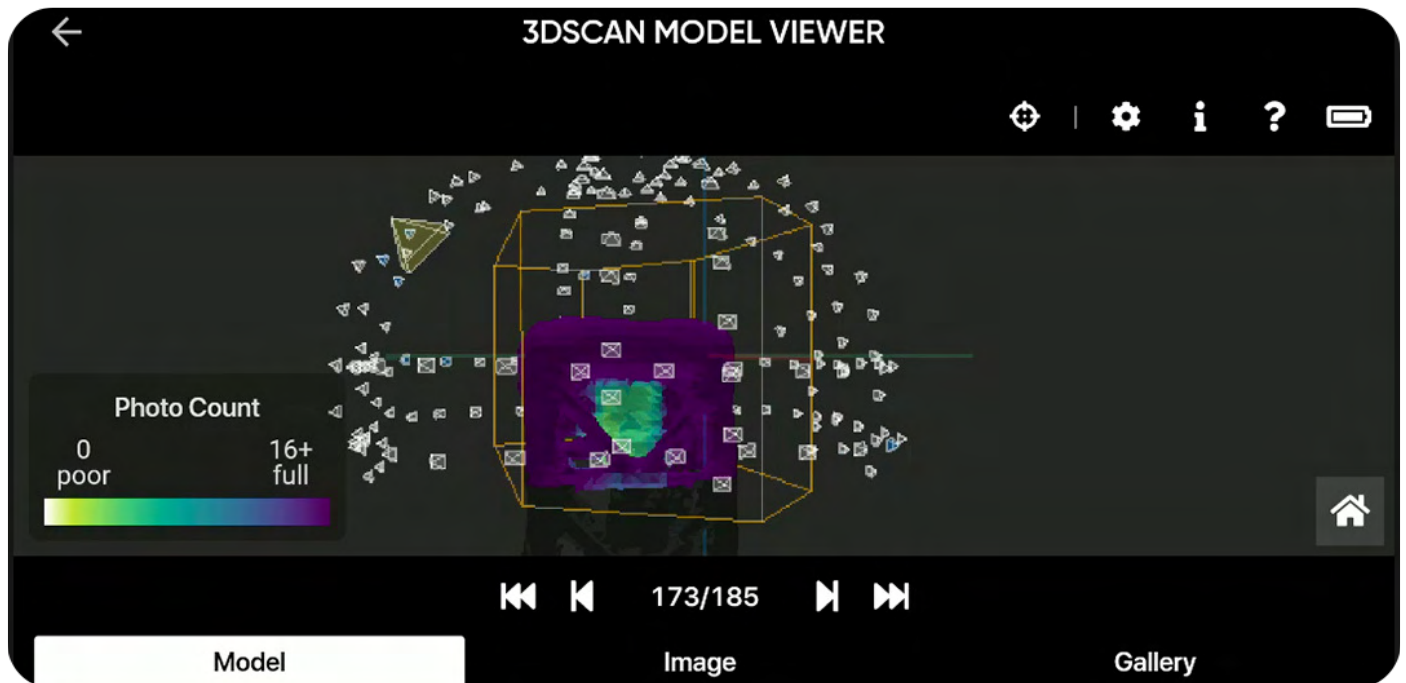

Capture Points

The frustum shapes surrounding the scan

- Select individual capture points to view photos
- The frustum will turn blue to denote you have already viewed that point

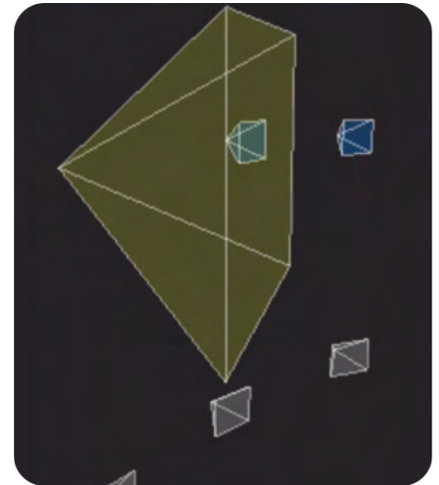
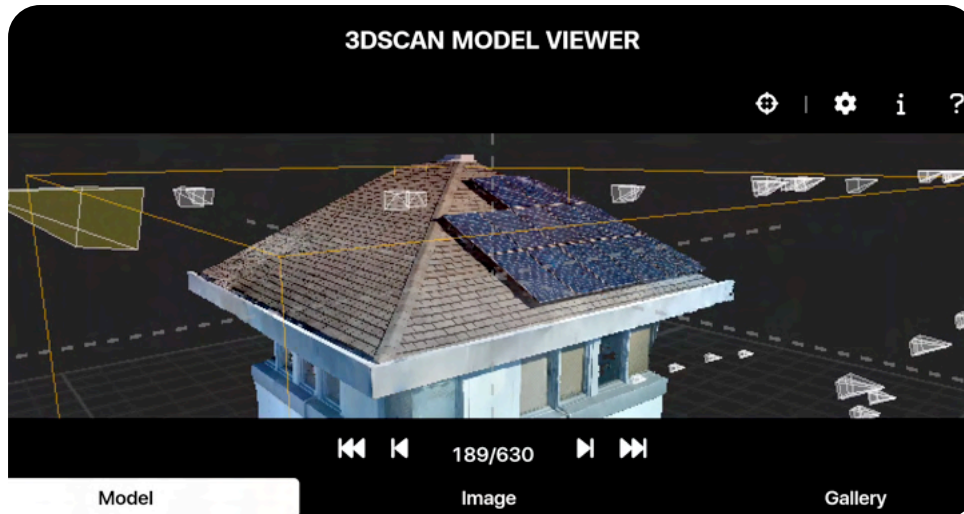

Home

Resets to the default view

Battery

Indicates the battery level of your drone

Inspect Tool 

Allows you to pick any point on the model and filter for all images containing that specific point

- A red circle will appear on both the model and photo to show your current placement
- Use this tool in the field to review the settings and angles you chose and see where images are spatially located in relation to the model

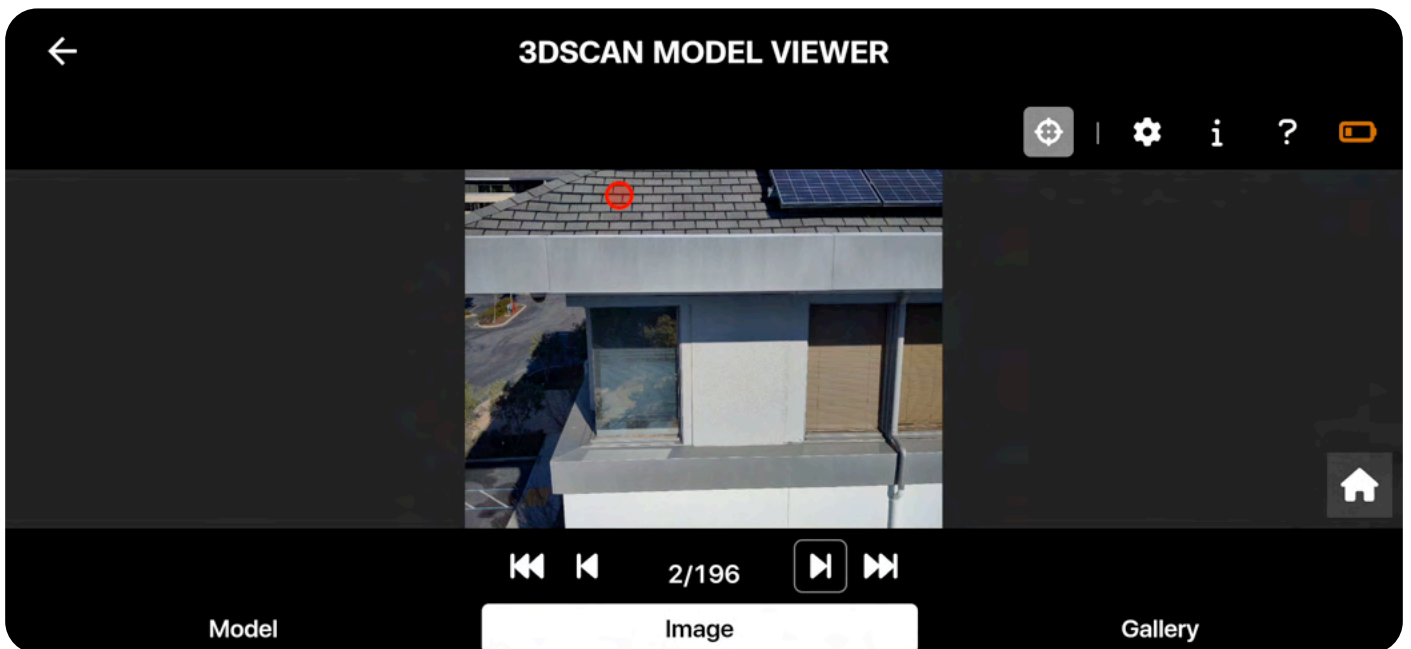
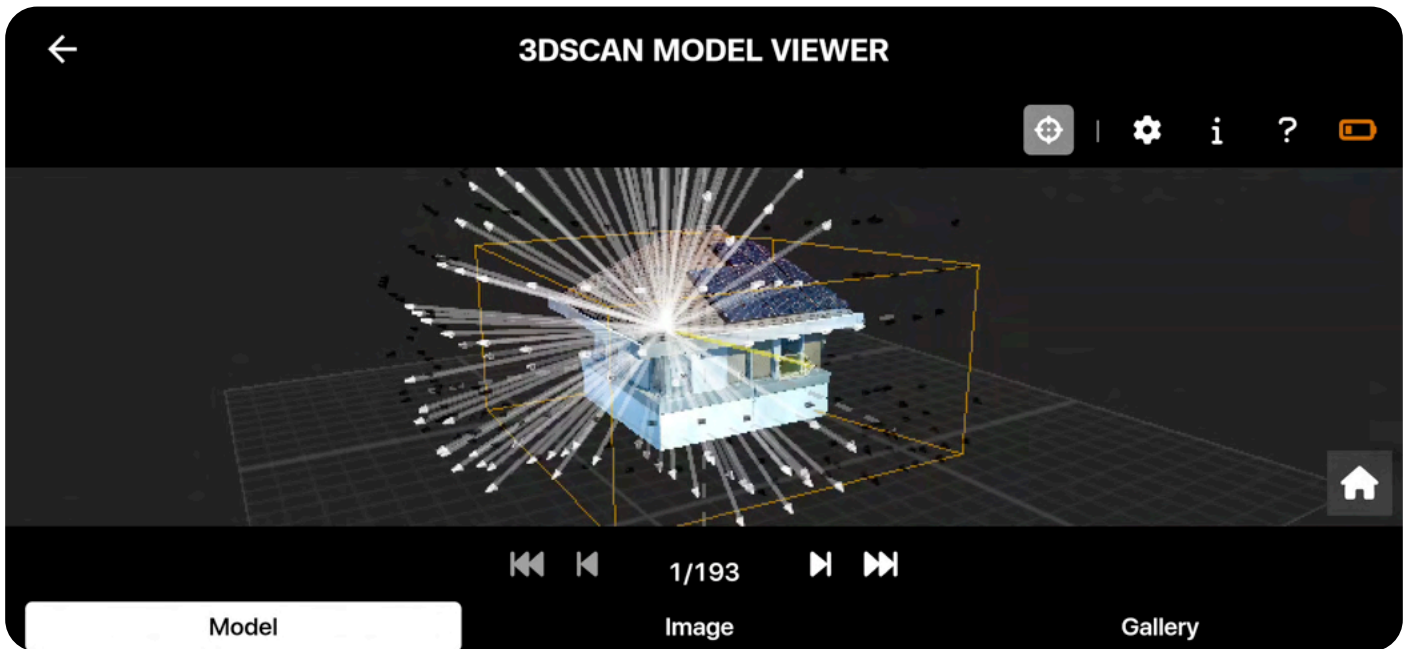

Settings ⚙️

Opens the Settings menu which allows you to adjust how your scan is displayed

Select Model Type*3D Coverage*

Displays an image coverage map that matches the in-flight AR Coverage Mesh

2D Coverage

Highlights the idealized plane at the bottom of the scan volume

*Onboard Model**

Displays textured 3D Models processed on-drone

*Onboard Map**

Displays Orthorectified 2D Maps processed on-drone

**Only available if you chose to generate a model*

Zoom to Selected Capture Point

Automatically aligns the 3D view with the active capture point

Show All Capture Points

Displays all capture points. When toggled off, this hides other points and displays only the active camera selected.

Show Volume

Displays a yellow prism around the structure to denote the user-defined scan volume

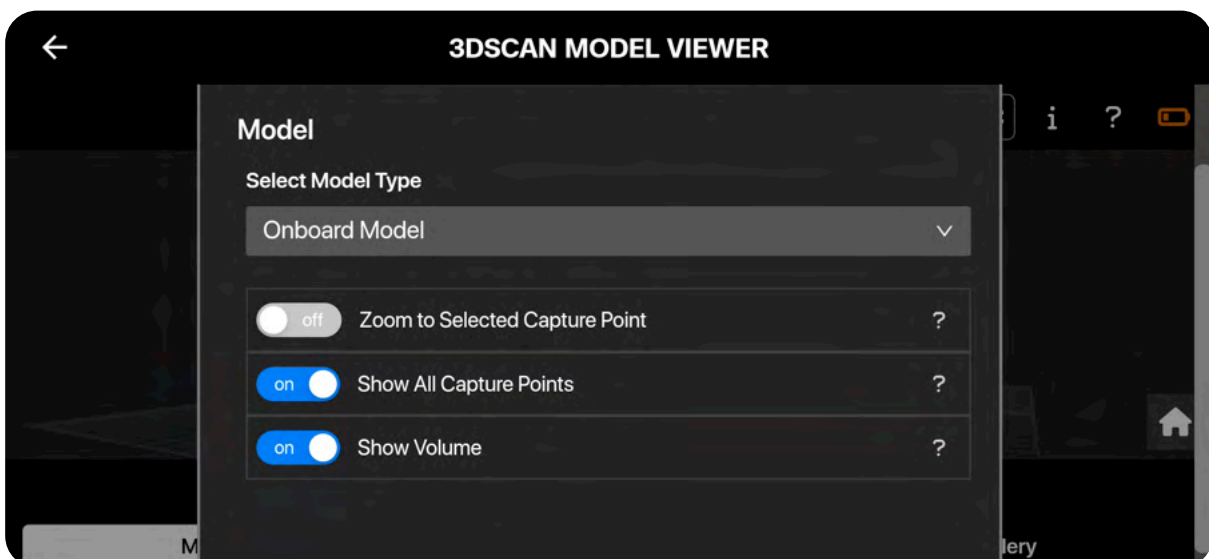

Info *i*

Summarizes information about the scan, the model, and the selected image including:

- Data
- Time of the scan
- Image size
- Scan name

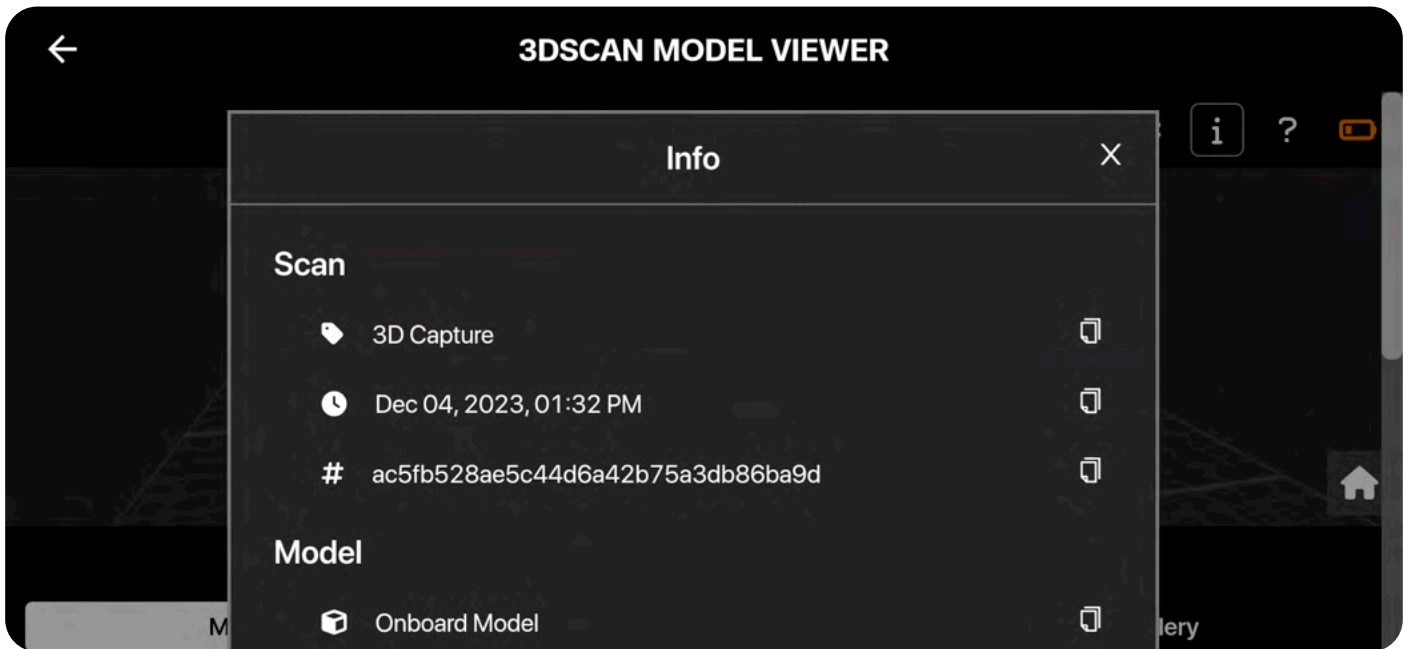

Help *?*

Provides information about how to navigate the Model Viewer

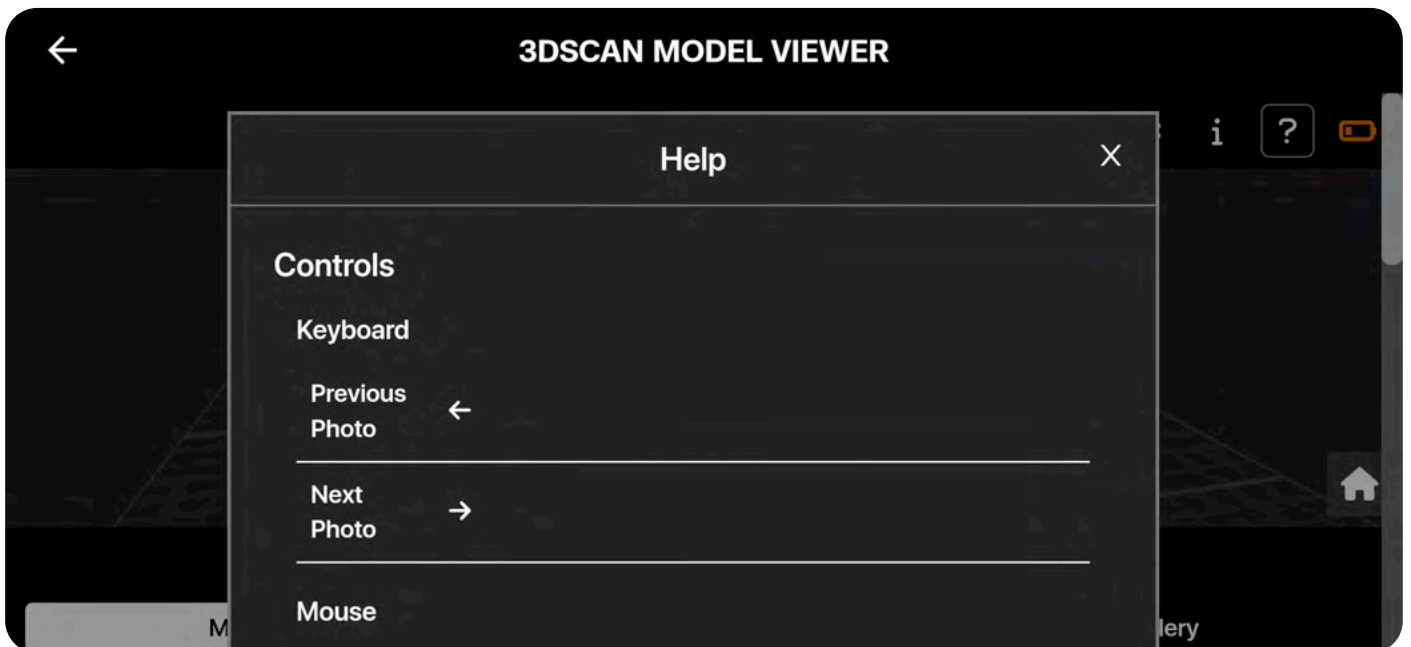

Exporting Onboard Maps or Models

Both **Onboard Models** and **Onboard Maps** are saved on the **Media card**. To access them, you will first need to [transfer your data](#) from Skydio X10.

You can offload your media two ways:

- Manually (either export using the Media microSD card or connect the drone to a laptop/computer via USB-C cable)
- Using Skydio Media Sync (not included with Skydio 3D Scan)

If you have already purchased Media Sync, Onboard Models and Onboard Maps are uploaded to Skydio Cloud along with other media files.

Files for onboard models can be found in the corresponding scan folders:

- 3D Capture
 - onboard_model.gltf
- Surface Capture
 - onboard_model.gltf
 - orthophoto.tiff
 - orthophoto_cloud_optimized.tiff (optimized for viewing on a laptop or in Skydio Cloud)

To view your modeling files on a laptop or computer, we recommend the following tools:

Windows

- Microsoft 3D Viewer and MeshLab for .gltf files
- Windows Photo Viewer for orthophoto.tiff files

Mac

- MeshLab for .gltf files
- MacOS Preview for .tiff files



Scan Settings

Review explanations of the settings available to you during your scan setup.

This section covers

Camera Settings

All Scan Mode Settings

3D Capture Settings

Visual Geofence

Take Best Photo

Extend Volume

Surface Capture Settings

Use Case Settings Overview

Ground Sample Distance

Camera Settings

Based on the available lighting conditions, your drone will automatically adjust photo settings to ensure it captures the best quality images. **Always monitor Flight Deck for in-app alerts** notifying you if there are problems with the lighting conditions.

Sensor Packages

There are two different sensor packages available with Skydio X10: the **VT300-Z** and the **VT300-L**.

- **VT300-Z** is tuned for long stand-off use cases in which increased zoom capabilities are preferred, and features a Narrow, Thermal, and Telephoto camera
- **VT300-L** is designed for optimal performance in lowlight environments, at short stand-off distances, and capturing wider shots. Features a Narrow, Wide, and Thermal camera, plus a flashlight

If you only have access to the Narrow camera via the VT300-Z, this sensor package can still be used for 3D modeling and photogrammetry, but **please note a few key trade-offs**:

- The Narrow camera is not as successful when capturing structures with complex geometry
- If you are scanning a structure with limited access or in a congested environment, you will see gaps in coverage for concave structures and incomplete reconstructions
- This is because the Narrow FOV requires a larger Distance to Surface (DtS), which may prevent the drone from reaching certain waypoints that are only attainable when scanning at closer distances

To effectively use the Narrow camera to create a reconstructed model, experiment with different DtS values to find one that ensures complete coverage and efficient time on-site.

For more information, read [Comparing Skydio X10 sensor packages for 3D Scan](#).



NOTE: We recommend setting your own White Balance value when scanning, as the default Auto White Balance could lead to color tint variations between images, resulting in poor reconstructions.

Zoom

Zooming is not available while actively scanning.

- VT300-Z sensor package defaults to the Narrow camera
- VT300-L sensor package defaults to the Wide camera

Focus

- 3D Scan defaults to **AutoFocus (AF)** when capturing images while scanning
- Manual Focus (MF) and Tap to Focus are only available during scan setup and manual capture



NOTE: You are able to utilize the flashlight on VT300-L while scanning. However, doing so may impact photogrammetry reconstruction results.

Photo Settings

Ensure you have configured the following photo settings, including thermal options, **before starting your scan**. Once scanning begins, cannot edit certain photo settings.

- When reviewing your scan images in the Media menu, only JPG images are shown. Transfer your media to access DNG or RJPEG files.
- DNG must be enabled for each independent scan, as settings do not persist.

File Type

Choose whether you want Skydio to capture JPG images only, or both JPG and DNG files.

JPG - Digital image format containing compressed image data.

DNG - RAW image format file, meaning it is not compressed and retains all original photo data. A DNG file is larger than a JPG file since it stores image data.

Resolution

Refers to the amount of detail in your video. Measured in megapixels.

Full - Images are captured at the highest quality, providing more detail and clarity.

1/4 - Images are captured at one-fourth of the full resolution, resulting in smaller file sizes. Best for scanning in lowlight conditions

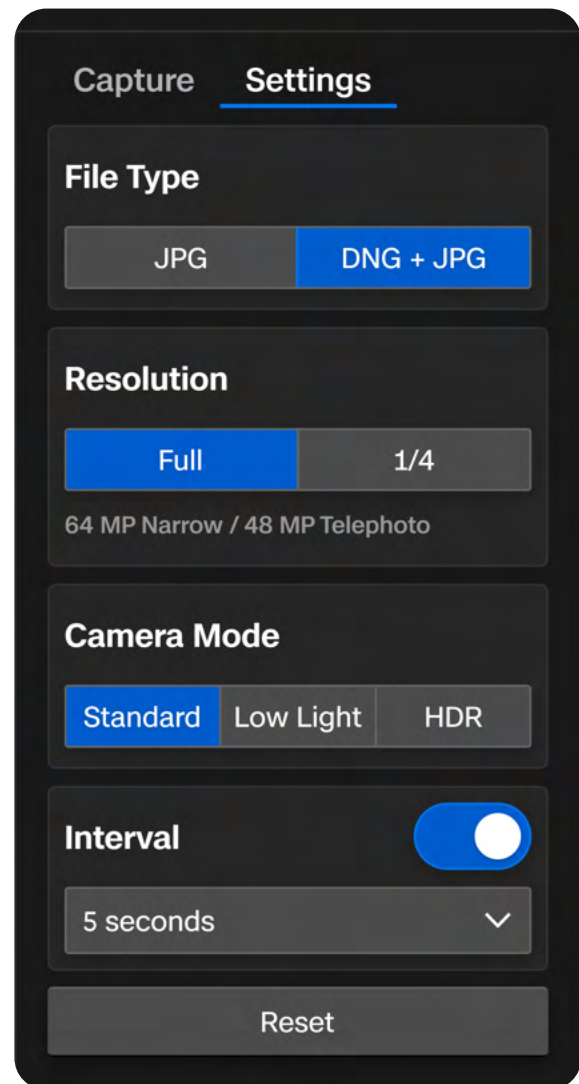

NOTE: Full Resolution DNG photos (64 MP with the Narrow lens, 50MP with the Wide lens) can only be captured when Stop for Photo is enabled. If you enable Full Resolution DNG capture, this will automatically toggle on Stop for Photo. This is to ensure the completion of writing files to the microSD card.

Camera Mode

Standard - Designed for typical, everyday lighting conditions. Provides a balanced, standard level of exposure, image processing, and contrast.

Low Light - Designed for environments with dim lighting, such as dusk or evening. Settings are adjusted to capture more light, reduce noise, and improve visibility. Only available with 1/4 Resolution,

HDR - Designed to capture environments with a wide range of brightness levels. Not recommended for use in brightly lit environments. Only available with 1/4 Resolution.



NOTE: When Interval is enabled, your drone will continuously capture photos at the specified time until the setting is disabled or the flight ends. Interval is only available when the scan is paused or when capturing photos manually. The fastest interval photo setting is five seconds.

Camera FOV

- When scanning with the VT300-L sensor package, you have the ability to select between the **Wide** and **Narrow** lenses in the **Scan Settings** step under **Camera FOV**
- The Wide lens is best for closeup inspections and allows the drone to scan faster, resulting in X10 traveling less total distance
- The Narrow lens is best for inspections that are further away, but your scan may take longer to complete

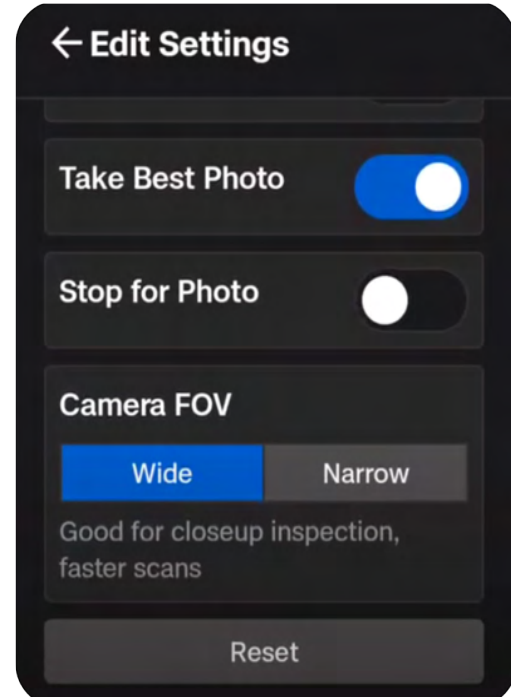

Thermal Settings

Thermal Capture

Enable to capture thermal images as JPG files.

RJPG - When enabled, your drone will capture a Radiometric JPG in addition to a standard JPG. A Radiometric JPG includes the radiometric data within the photo file.

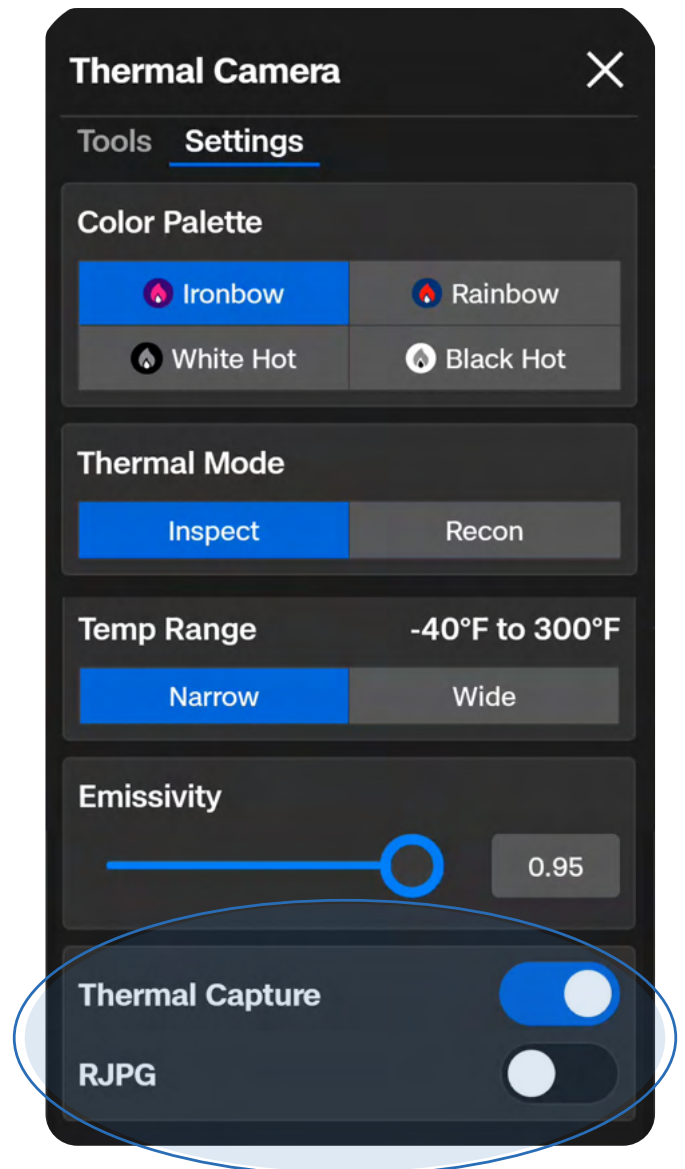

CAUTION: If you are flying with a sensor package that has a thermal sensor, please note that pointing a thermal camera into direct sunlight may cause permanent damage to the sensor.

All Scan Mode Settings

Settings will persist between scans of the same capture mode and through power cycles. If you would like to restore settings back to default, select the reset button in the top right on the workflow pane during the Review or Edit Settings steps of a scan.

The following settings are available in all capture types.

Overlap Percentage

Overlap between photos along a path. High overlap is recommended for complex scenes. Default Overlap varies based on the capture type.

Sidelap Percentage

Sidelap between two adjacent flight paths. High sidelap is recommended for complex scenes. Default Sidelap varies based on the capture type.

The thermal camera has a different Field of View (FOV) compared to the color (RGB) camera. **Due to this, the corresponding Overlap and Sidelap, as well as GSD (Distance to Surface), values will be different.** The values in the workflow pane on the right represent the color camera settings.

- You will see a summary of the thermal setting values displayed on the bottom of the live camera feed

If you are conducting a thermal scan and want a higher Overlap/Sidelap or GSD, increase these settings in the workflow pane until you reach your desired values.

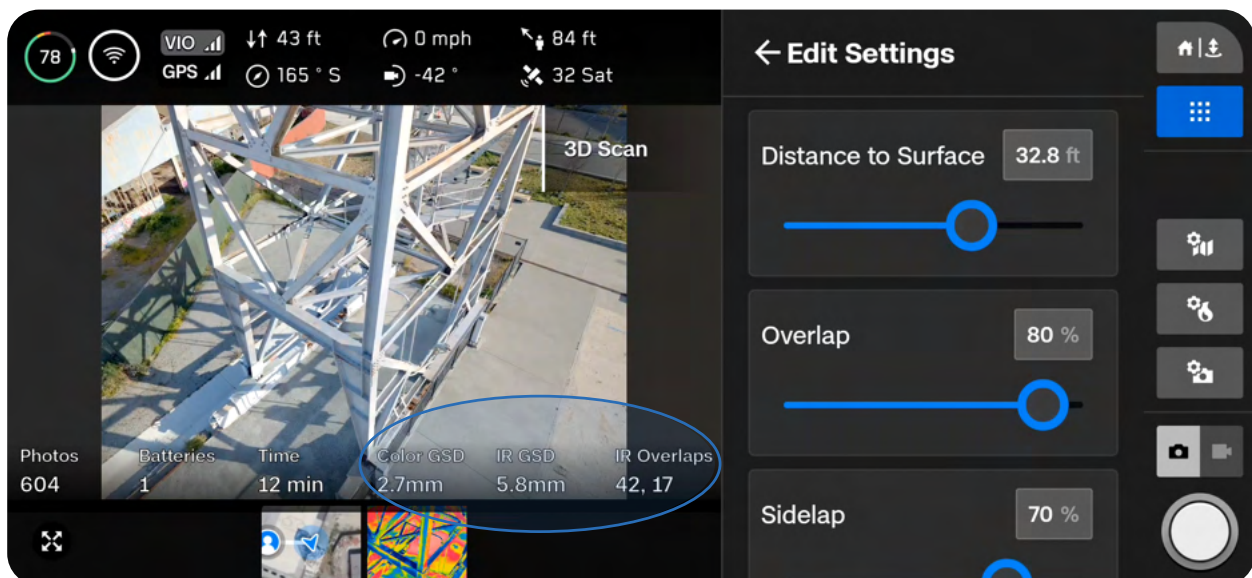

Stop for Photo

By default, the drone will fly through image capture points without stopping for smooth and efficient flight. Skydio will automatically set the best speed to capture photos based on your scan distance and lighting conditions, while ensuring your images remain crisp and clear.

Toggle on **Stop for Photo** if you would like Skydio to stop before capturing a photo at each capture point. The drone will still accelerate between capture points.

- Enabling this setting significantly increases the amount of time and batteries required to complete your scan

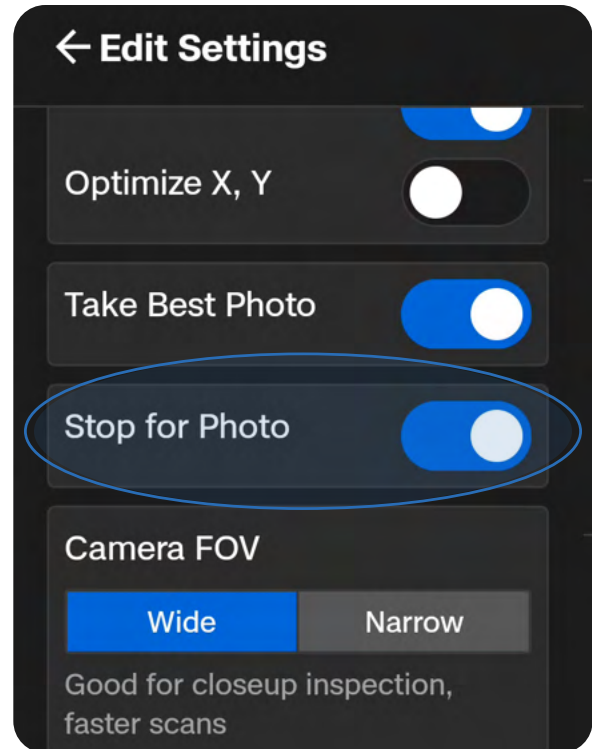

NOTE: Even if *Stop for Photo* is disabled, you may see the drone pause, along with a “Saving Photos” notification. This is to ensure the SD card finishes writing the data. Autonomous scanning will resume automatically.



NOTE: Full Resolution DNG photos (64 MP with the Narrow lens, 50MP with the Wide lens) can only be captured when *Stop for Photo* is enabled. If you enable Full Resolution DNG capture, this will automatically toggle on *Stop for Photo*. This is to ensure the completion of writing files to the microSD card.

Speed Slider

Use the **Speed slider** to set the maximum speed at which Skydio will travel while exploring, scanning and when returning to the Launch Point or Rally Point.

- Adjust this setting within the Explore settings or when reviewing the scan settings
- Speed options vary depending on your scan mode

While Skydio Obstacle Avoidance is robust, thin structures can be difficult to avoid. When scanning objects with cables or other thin or narrow features, try decreasing your speed.

3D Capture

- Minimum speed: 1.1 mph (0.5 m/s)
- Maximum speed: 11.2 mph (5 m/s)
- Default speed: 11.2 mph (5 m/s)

Surface Capture

- Minimum speed: 1.1 mph (0.5 m/s)
- Maximum speed: 11.2 mph (5 m/s)
- Default speed: 5.6 mph (2.5 m/s)

Indoor Capture

- Minimum speed: 1.1 mph (0.5 m/s)
- Maximum speed: 8 mph (3.5 m/s)
- Default speed: 8 mph (3.5 m/s)

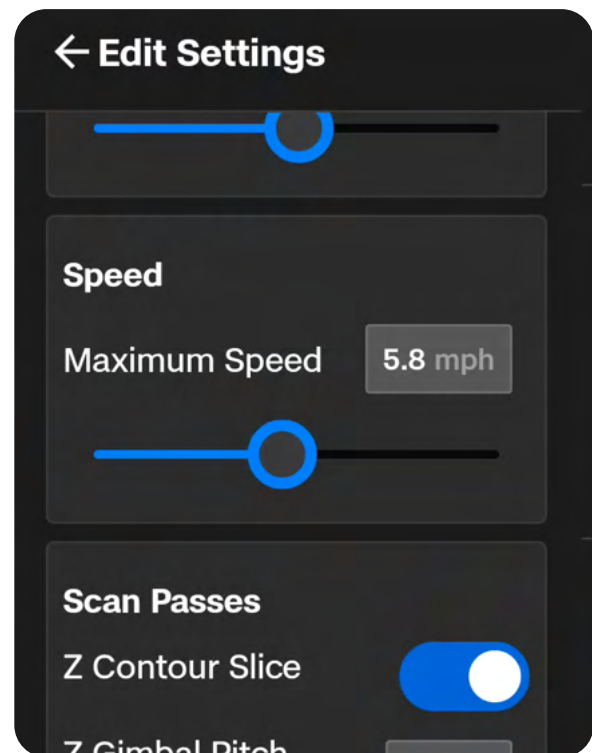

3D and Indoor Capture Settings

Scan Passes

Organizes the capture path into three continuous slices, Z, Y, and X.

The Z slices are completed first and resemble orbits at fixed heights going around the structure. By default, the sensor package angle is set to 45 degrees. Use the **Z Gimbal Pitch** slider to adjust the camera angle at which the drone will capture photos while orbiting. Increased gimbal pitch results in capturing less sky and more photos of the surrounding area and structure itself.

Adjusting the Z Gimbal Pitch is useful in situations where:

- You want to capture the ground in every photo for improved reconstructions
- You intend to leverage third party reconstruction software and want to minimize the number of photos containing sky
- You need to include the ground in your photos to capture Ground Control Points (GCP) at your scan site

If you are using the Z Slice to efficiently capture large, relatively simple vertical surfaces (e.g., facades), we recommend leaving the default Z Gimbal Pitch. If you have only the Z Slice enabled, we recommend adjusting the Z Gimbal Pitch to zero.

The Y and X slices follow and resemble a cross hatch pattern.

We recommend leaving all three slices enabled. You have the option to independently toggle each of the scan slices as needed. If all three slices are disabled, you will be unable to start the scan.



INFO: For faster scans, toggle on only the Z pass around structures that do not need to be viewed from above or below.



NOTE: The camera gimbal pitch represents the angle below the horizon.

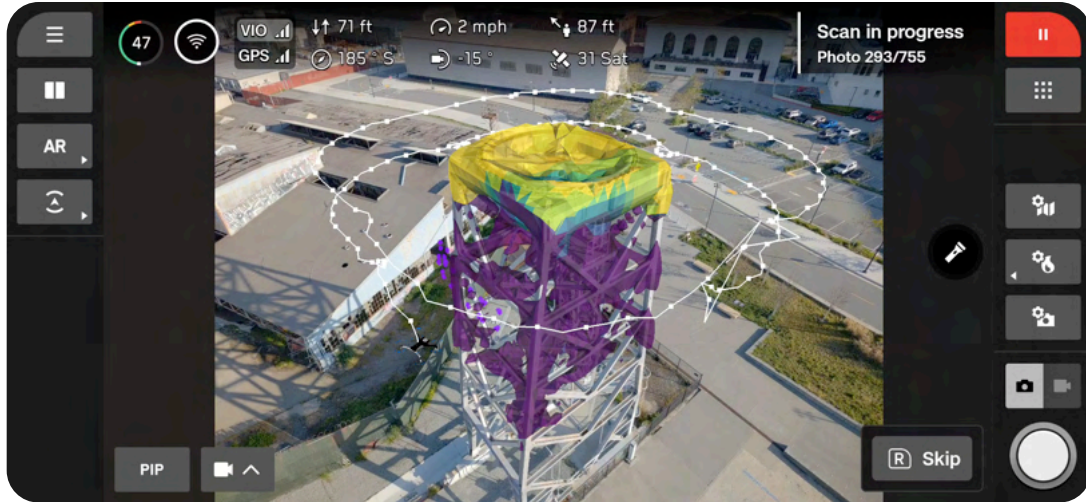

Z slice

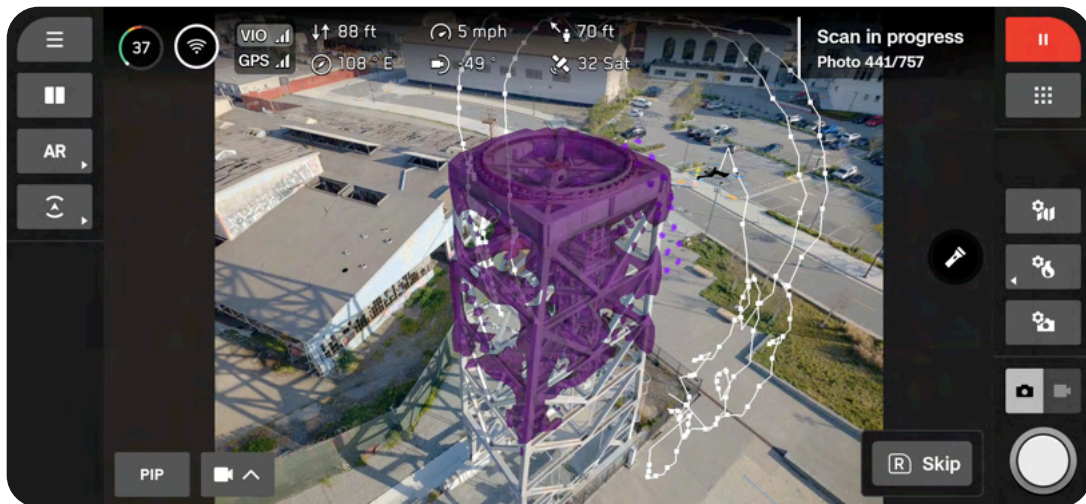

Y slice

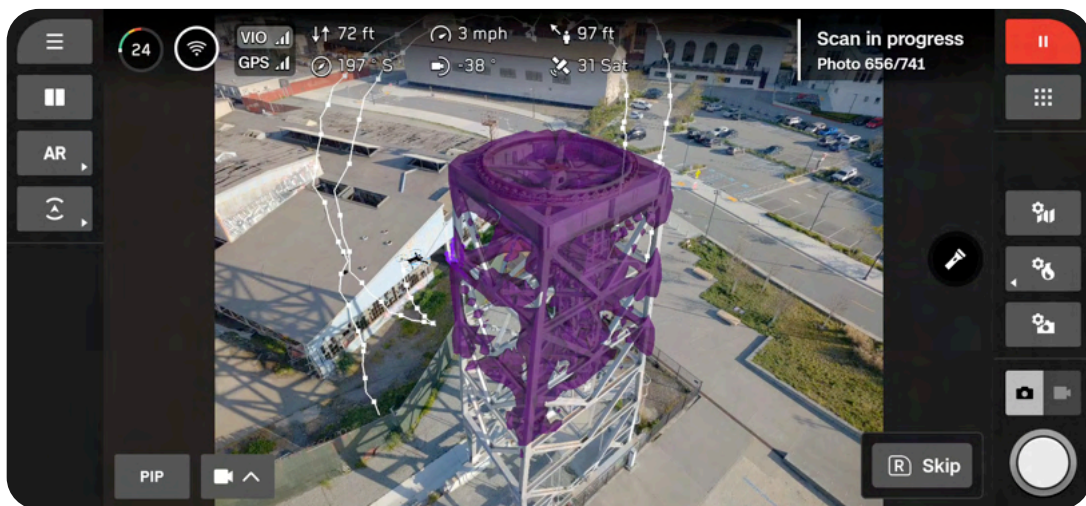

X slice

Distance to Surface (DtS)

Determines how close the drone will fly to the structure or area being scanned. Smaller distance to surface (closer) means more photos taken and higher resolution, but an increased total scan time. The Distance to Surface corresponds directly to Ground Sample Distance (GSD) which defines the distance between two consecutive pixel centers on the ground. For example, a one-millimeter GSD would suggest that the distance of the two consecutive pixel centers in the photo reflects one millimeter on the ground.

- DtS range for 3D Captures and Indoor Captures is 4.9 ft - 49.2 ft (1.5 m - 15 m)



NOTE: *When scanning homogenous surfaces, such as solid steel or concrete structures, we recommend increasing your Distance to Surface. Scanning too close to such structures may result in difficulties when creating a reconstruction.*

For tables that show GSD values at various fixed DtS, refer to the Distance to Surface section below.

Visual Geofence

The Visual Geofence gives you the ability to further constrain the drone to a safe flight area while scanning autonomously. By default, the drone will remain within an area defined by the scan volume and the scan distance.

- Uses the visual navigation system to always enter and exit the 3D volume from the same location without the use of GPS
- Skydio will honor the Visual Geofence during the Explore phase and the scanning process, as well as when transitioning between the two

This setting gives you the ability to toggle on or off three independent visual geofences: **Ceiling**, **Floor**, and **Walls**. When enabled, each geofence blocks flight outside of the scan volume along that plane. If an image capture point is located outside of a toggled fence boundary, Skydio will not fly there and instead skip those capture points.

- **Strict Ceiling** uses the maximum height geofence
- **Strict Floor** uses the minimum height geofence
- **Strict Walls** uses the lateral (pillars) geofence

EXAMPLES: *When scanning a bridge, toggle the Ceiling geofence to avoid flying over the bridge deck; if you are scanning close to private property, toggle the Walls geofence to avoid flying over the property.*

Safe Distance

When setting the Visual Geofence, you will see the option for another setting called **Safe Distance**. Enabling Safe Distance allows you to **set a minimum distance the drone will stay away from objects and structures during autonomous flight**. Safe Distance is not active when piloting manually.

For example, enable this setting if you want to avoid flying near or through obstacles, such as a lattice tower, during exploration or while scanning.



NOTE: Safe Distance can be set between 3.3-9.8 ft (1-3 m).

The Safe Distance value cannot be greater than the specified Distance to Surface. Use the smallest possible Safe Distance value for best results.



NOTE: Skydio 3D Scan uses Standard Obstacle Avoidance. Increase Safe Distance as an added safety measure to increase the distance Skydio stays away from obstacles and structures. Enabling this setting may lead to gaps in coverage of some areas, such as concave surfaces. Ensure Take Best Photo is enabled to assist in capturing all surfaces.

The value you set for your **Safe Distance** is independent of **Distance to Surface** and should not be calculated as an addition to your **Distance to Surface**. The GSD will not be affected by increasing **Safe Distance**. See the below images for a visualization.

In these images, the pink region represents **Safe Distance**.

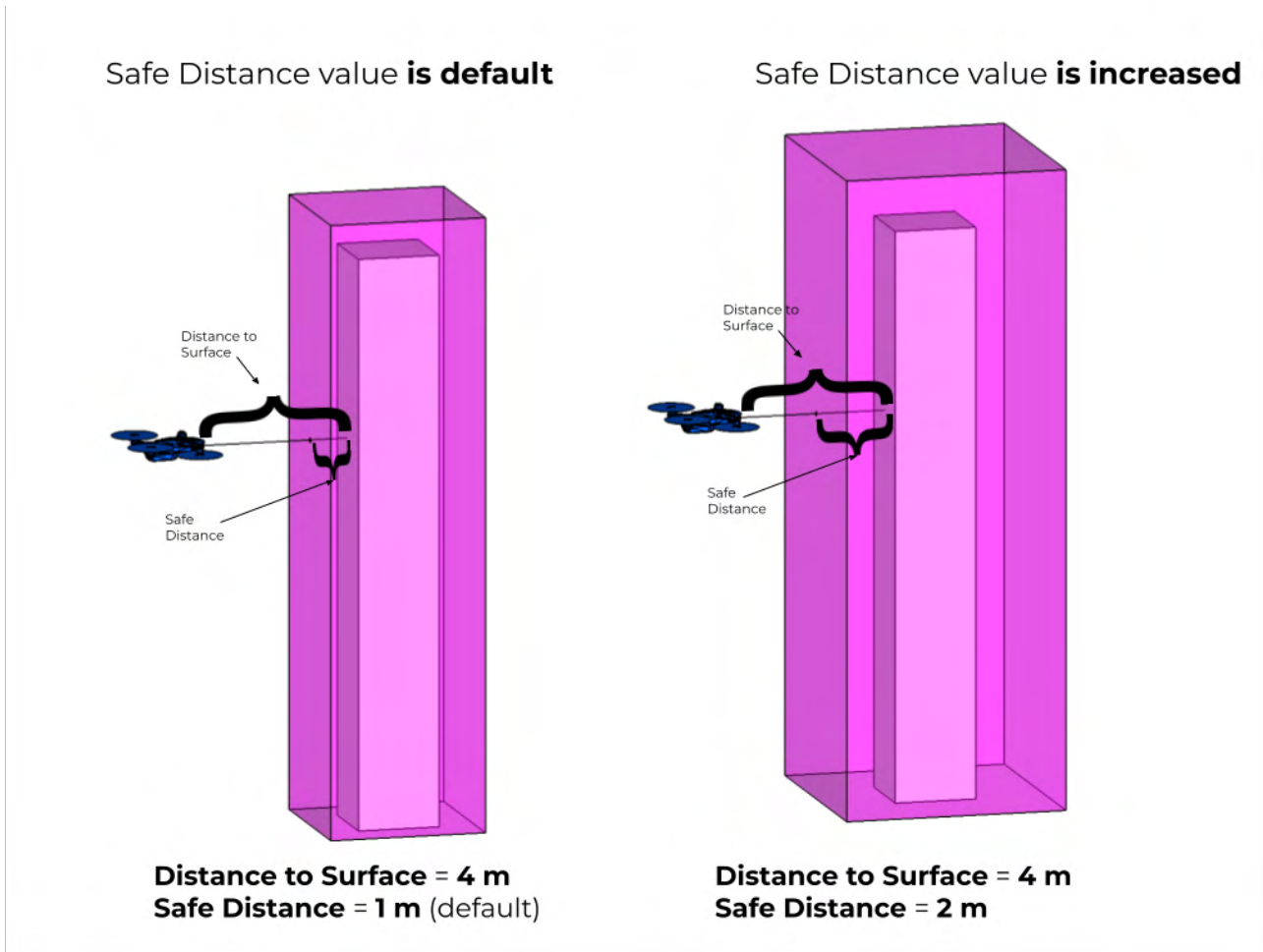

Take Best Photo

Skydio will intuitively adjust the Distance to Surface and image capture locations if it runs into obstructions at any point during the scan, allowing you to capture images in tight spaces. As the Distance to Surface is adjusted, the GSD will automatically update.



NOTE: This setting is **ON** by default for all scan modes.

If Take Best Photo is toggled off, Skydio will skip capture points located outside of the yellow geofence (left photo). Take Best Photo allows Skydio to capture all surfaces of the structure you are scanning while safely avoiding collisions.

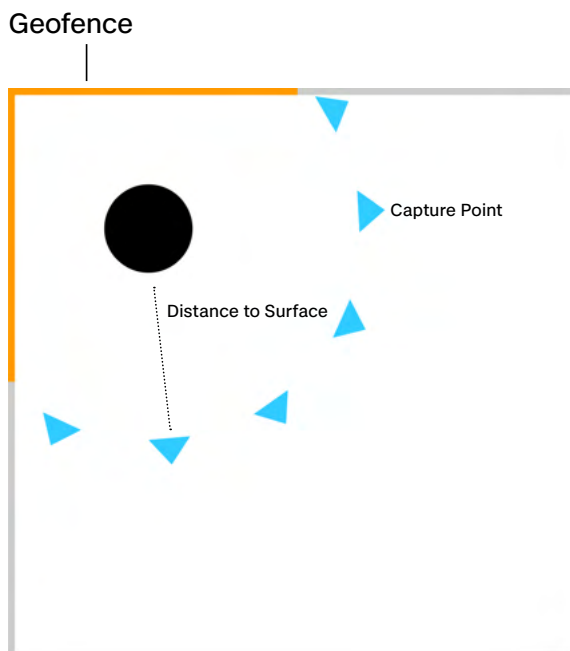

Take Best Photo: OFF

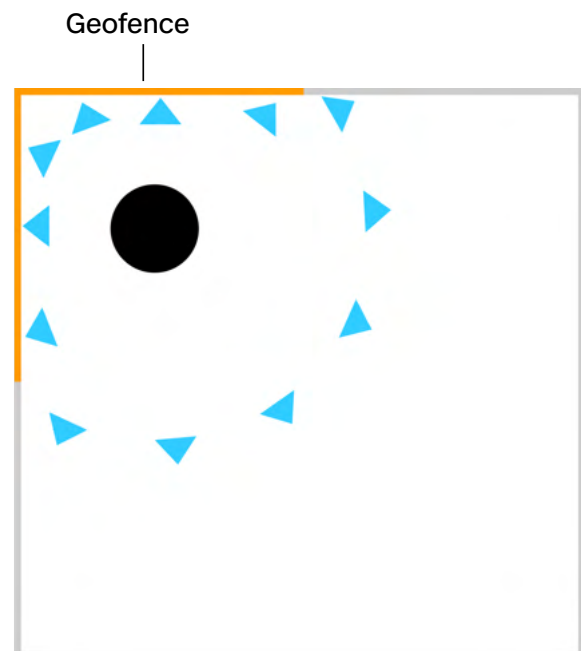

Take Best Photo: ON



NOTE: Safe Distance will always be respected, regardless of your other settings.

Extend Volume

Extend Volume expands the scan volume beyond the Floor, Ceiling or Walls.

Use the adjustable distance slider to set the distance at which Skydio will capture photos outside of the scan volume.

Different scan modes have different default states for Extend Volume. Check the **Overview** of the capture type to know what is enabled by default.

If a Strict Geofence is enabled, the drone will capture photos of surfaces located outside of the scan boundaries without physically flying there.

In the diagram below, the maroon region represents the scan volume. When a Strict Geofence and Extend Volume are enabled, Skydio **will not leave the Strict Geofence region** and will only face outward to capture images located in the Extend Volume region.

Extend Volume is useful for indoor scanning or when you need to capture the underside of a bridge.

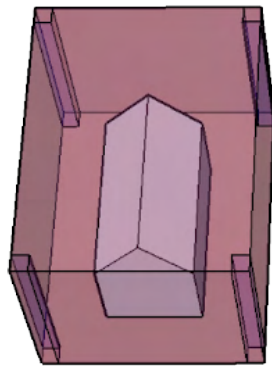

Geofence: **Strict**
Extend Volume: **OFF**

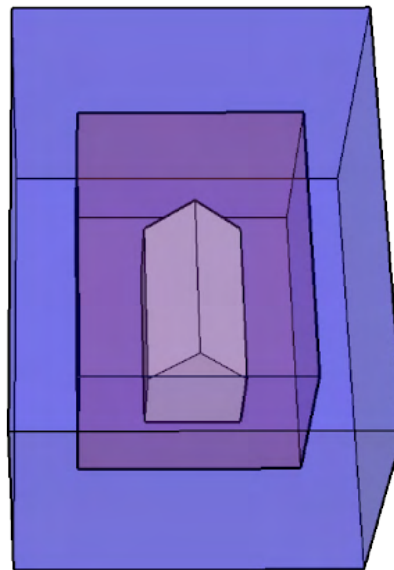

Geofence: **Strict**
Extend Volume: **ON**



CAUTION: The Extend Volume distance should not be larger than your Distance to Surface (DtS). If this happens and a Strict Geofence is enabled, no photos will be captured of objects in the Extend Capture Area.

Optimize X, Y

Enabling this setting allows you to maintain full coverage while skipping redundant imagery that was captured in earlier scan passes during the X and Y passes. For example, if a certain capture point is covered during the Z pass, Skydio will intelligently skip this photo during the X and Y passes.

Optimize X,Y significantly improves efficiency of capturing images. Fewer images will be captured while maintaining full coverage, including unnecessary photos of the horizon and sky. Find this setting within the **Scan Passes** setting menu. View the areas that will be skipped by previewing the planned flight paths in the Review Settings step.

The image on the right shows “gaps” in the Y and X slices. These represent photos that were already captured during the Z scan pass, meaning Skydio will skip those points and only capture areas that have not yet been photographed.

Avoiding duplicate photos decreases the total scan time and total number of photos captured while maintaining full coverage.

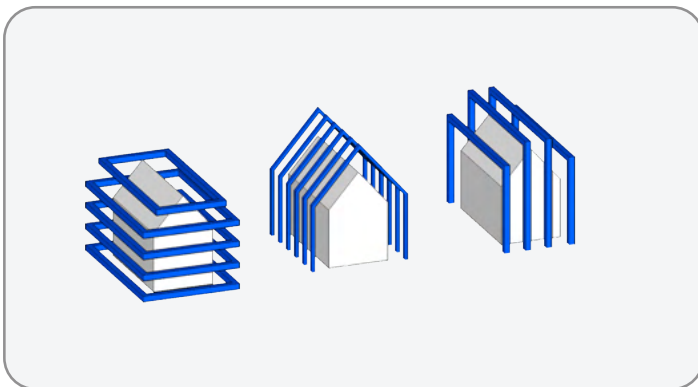

Optimize X, Y: **OFF**

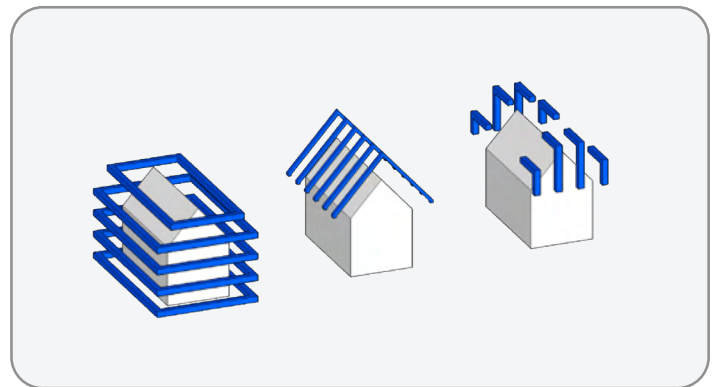

Optimize X, Y: **ON**



NOTE: The X and/or Y scan passes must be enabled, along with Optimize X, Y to activate this setting.

Surface Capture Settings

Distance to Surface (DtS)

The most important setting for Surface Captures. Lower height means more photos taken and higher resolution, but an increased total scan time. In Surface Capture, the Height is relative to the Surface you set. The Height corresponds directly to Ground Sample Distance (GSD). Set the Height higher than the slider options by piloting the drone to your desired height and tapping the **Set Distance to Current** button.

- DtS range for Surface Capture is 3.3 ft - 49.2 ft (1 m - 40 m)

For tables that show GSD values at various fixed DtS, refer to the Distance to Surface section below.

In order for Skydio X10 to capture the underside of a structure, such as underneath a bridge, the underside of a parking garage, or an interior roof, you must enable the **Upward Capture** toggle in scan settings.

- Pilot your drone below the scan Surface, then enable Upward Capture when reviewing scan settings
- This ensures your drone will automatically move the camera sensor package to look up when it detects the height of the drone is below the specified scan Surface

Cross Hatch

Capture oblique images by enabling the Cross Hatch setting. When enabled, Skydio will capture in a rotating lawn mower pattern.

- This increases the number of photos but provides better oblique imagery for reconstruction
- Instead of capturing top-down (nadir), the camera gimbal angle is adjustable to capture images at an angle for more detailed reconstruction
- The sensor package angle range is 55°-85° and set to 60° by default

When disabled, the drone will capture photos in a nadir (top-down) lawn mower pattern.



INFO: The camera gimbal angle represents the angle below the horizon.

Perimeter

Scan 3D volumes by traversing the 2D perimeter at multiple heights and taking pictures inward.

- The Perimeter takes place at the end of the scan, and the additional inward photos will improve reconstruction
- This is a good setting to enable when scanning vertical structures like tall buildings or towers
- The sensor package angle range is 0°-90° and set to 60° by default



INFO: *The camera gimbal angle represents the angle below the horizon.*

Use Case Example Settings

Default 3D Scan settings are optimized for photogrammetry reconstruction, however, there may be cases when you need to adjust settings, such as Overlap and Sidelap or the camera resolution, to better capture the scene.

If your goal is to create a high fidelity reconstruction, increase your Overlap/Sidelap percentages. If you do not plan to create a model of your scan, lower percentages will suffice.

- For optimal photogrammetry reconstructions, we do not recommend overlap/sidelap under 70/70



NOTE: Increasing Overlap and Sidelap increases the number of images, scan time, and post-processing time.

When scanning homogeneous surfaces, such as solid steel or concrete structures, we recommend setting a Distance to Surface of at least 32 ft (10 m) for the Narrow camera and 16 ft (5 m) for the Wide camera.

- If you do not have enough space to do so (e.g., not enough access underneath a bridge or not enough space inside the warehouse), we recommend to increasing Overlap/Sidelap to 85/85

3D Capture Use Cases and Suggested Settings

Industry Use Case	Example GSD	Resolution	Stop for Photo	Scan Pass
Construction: Progress monitoring and asset inspection Artifacts to detect: Asset damage, misalignment, as-built vs. design	2 mm	Full	OFF	Z, Y, X
Transportation: Bridge inspection Artifacts to detect: Cracks and delamination of the bridge deck, bolts/nuts, connection points of bridge pillars	1 mm	1/4 Standard	ON	Z, Y, X
Utilities: Distribution Artifacts to detect: Transformers, conductors, insulators, static wire, pole quality/damage	1 mm	Full	OFF	Z
Oil & Gas: Asset Inspection Artifacts to detect: Surface corrosion or level changes of tanks, pipe damage or spills along the pipe, equipment failure	2 mm	Full	OFF	Z, Y, X

Surface Capture Use Cases and Suggested Settings

Industry Use Case	Example GSD	Resolution	Stop for Photo
Transportation: Bridge inspection Artifacts to detect: Cracks and delamination in the concrete underneath the bridge	1 mm	1/4 Standard or 1/4 HDR	ON
First responders: Daytime small collision scene or collision scenes with complex shapes Artifacts to detect: Crumple damage, skid marks, weapons, broken glass	5 mm	Full	OFF
First responders: Nighttime small collision scene or collision scenes with complex shapes Artifacts to detect: Crumple damage, skid marks, weapons, broken glass	5 mm	1/4 Low Light	ON
Construction: Rooftop inspection Artifacts to detect: Cracks, holes, or debris on the roof surface	2 mm	Full	OFF

Indoor Capture Use Cases and Suggested Settings

We recommend using the **Wide camera** for best photogrammetry reconstruction results and the most efficient time onsite.

If you plan to use the Narrow camera during an Indoor Capture, we recommend using a large Distance to Surface for better photogrammetry reconstruction results. We also recommend 1/4 resolution for indoor environments that are not well lit. For more information, read [Comparing Skydio X10 sensor packages for 3D Scan](#).

Industry Use Case	Example GSD	Resolution	Stop for Photo
Transportation: Tunnel inspection Artifacts to detect: Defects or cracks in tunnel walls and ceilings	2 mm	1/4 Low Light	ON
Warehousing: Warehouse and Inventory Management Artifacts to detect: Layout of empty warehouses for planning purposes, aisles and pallets for inventory counting and monitoring	2 mm	1/4 Standard	ON

Ground Sample Distance

The following tables represent DtS values for 3D Capture and Indoor Capture

The DtS corresponds directly to Ground Sample Distance (GSD), which defines the distance between two consecutive pixel centers on the ground. For example, a one-millimeter GSD would suggest that the distance of the two consecutive pixel centers in the photo reflects one millimeter on the ground.

Default settings are optimized for 3D reconstruction.

Skydio X10 Wide camera GSD at various fixed DtS

Distance to Surface (m)	Distance to Surface (ft)	Full Resolution (50MP) GSD (mm)	1/4 Resolution (12MP) GSD (mm)
1.5	4.9	0.31	0.62
2	6.6	0.41	0.83
3	9.8	0.62	1.24
4	13.1	0.83	1.65
5	16.4	1.03	2.07
6	19.7	1.24	2.48
7	23	1.45	2.89
8	26.2	1.65	3.31
9	29.5	1.86	3.72
10	32.8	2.07	4.13
11	36.1	2.27	4.55
12	39.4	2.48	4.96
13	42.7	2.69	5.37
14	45.9	2.89	5.79
15	49.2	3.1	6.2

Skydio X10 Narrow camera GSD at various fixed DtS

Distance to Surface (m)	Distance to Surface (ft)	Full Resolution (64MP) GSD (mm)	1/4 Resolution (16MP) GSD (mm)
1.5	4.9	0.12	0.24
2	6.6	0.16	0.32
3	9.8	0.24	0.48
4	13.1	0.32	0.65
5	16.4	0.4	0.81
6	19.7	0.49	0.97
7	23	0.57	1.13
8	26.2	0.65	1.3
9	29.5	0.73	1.46
10	32.8	0.81	1.62
11	36.1	0.89	1.78
12	39.4	0.97	1.94
13	42.7	1.05	2.11
14	45.9	1.13	2.27
15	49.2	1.21	2.43

The following tables represent DtS values for Surface Capture

Skydio X10 Wide camera GSD at various fixed DtS

Distance to Surface (m)	Distance to Surface (ft)	Full Resolution (50MP) GSD (mm)	1/4 Resolution (12MP) GSD (mm)
1.5	5	0.31	0.62
3	10	0.41	0.83
4.6	15	0.62	1.24
6.1	20	0.83	1.65
9.1	30	1.03	2.07
12.2	40	1.24	2.48
15.2	50	1.45	2.89
22.9	75	1.65	3.31
30.5	100	1.86	3.72
45.7	150	2.07	4.13
61	200	2.27	4.55

Skydio X10 Narrow camera GSD at various fixed DtS

Distance to Surface (m)	Distance to Surface (ft)	Full Resolution (64MP) GSD (mm)	1/4 Resolution (16MP) GSD (mm)
1.5	5	0.12	0.24
3	10	0.24	0.49
4.6	15	0.37	0.74
6.1	20	0.49	0.99
9.1	30	0.74	1.47
12.2	40	0.99	1.98
15.2	50	1.23	2.46
22.9	75	1.85	3.7
30.5	100	2.47	4.94
45.7	150	3.7	7.4
61	200	4.94	9.87



Accessing Scan Data

Retrieve valuable contextual scan data post-flight. Review this section for guidance on exporting scan data.

This section covers

3D Scan Files

File Types

3D Scan Files

Retrieve valuable contextual scan data post-flight. You can offload your media two ways:

- Manually (either export using the Media microSD card or connect the drone to a laptop/ computer via USB-C cable)
- Using Skydio Media Sync (not included with Skydio 3D Scan)

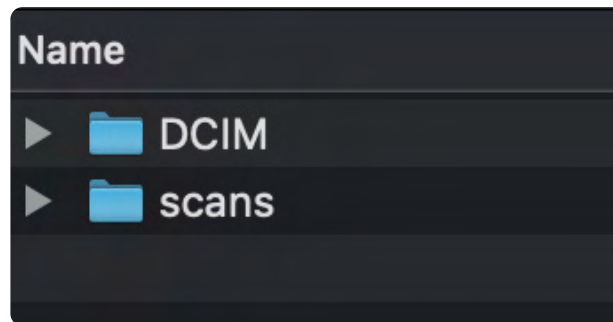

When transferring your data, you will see two folders:

DCIM (Digital Camera Images) contains a subfolder titled **100SKYDO** which houses low-resolution video files (.LRV) of your scan. You will not need these files to create 3D reconstructions.

Scans contains individual scans titled by scan name followed by a UTC timestamp.

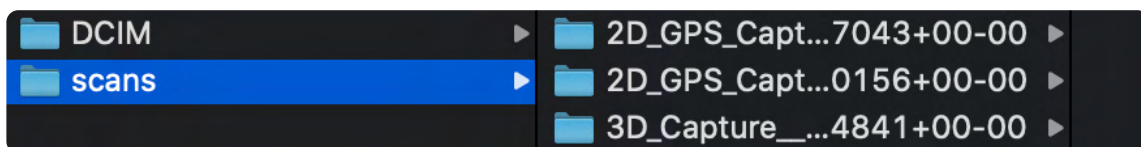

File Types

After selecting the scans folder, you will see a few different types of files inside.

Capture_Report.html

Includes a report with the summary of your scan details. Click this to view a webpage that outlines the following information:

- Scan ID
- Time and date
- GPS location
- Scan setting details (scan mode, overlap, sidelap, scan passes etc.)
- Scan area
- Number of pillars set
- Number of batteries used
- Total flights and flight time
- Total number of images (captured manually and autonomously)

Scan_coverage.gltf

- Graphics Language Transmission Format (.gltf)
- A standard file format for models
- Displayed in the Model Viewer

Onboard_model.gltf

- Graphics Language Transmission Format (.gltf)
- Created when an Onboard Model is generated

Pix4D_Mapper_geolocation.csv

A file that includes metadata specifically for use in Pix4DMapper

Pix4D_Matic_geolocation.csv

A file that includes metadata specifically for use in Pix4DMatic

Scan_output.pbuf

This file contains serialized metadata about your scans

- You will not need this to create 3D reconstructions, but it is used to enable the Model Viewer
- **Do not delete this file**

Orthophoto.tiff and Orthophoto_cloud_optimized.tiff

- Tagged Image File Format (.tiff)
- Generated with a Surface Capture
- A file format used for storing high-quality images

Joint Photographic Experts Group (.JPG)

A JPG file is a digital image format containing compressed image data

- These are the images you captured during your scan
- You will need these files for creating reconstructions in photogrammetry software programs

Digital Negative (.DNG)

A DNG file is a RAW image format file, meaning it is not compressed and retains all original photo data

- A DNG file is larger than a JPG file since it stores image data
- If you enabled DNG capture during your scan, you will need these files for creating reconstructions in photogrammetry software programs



Contingency Behaviors

Learn about the behaviors during events such as lost connection or low battery. Always monitor Skydio Flight Deck for in-app alerts.

This section covers

Lost Connection

Low Battery

Environmental Factors

Lost Connection

If Skydio loses connection to the Skydio Controller or mobile device during a scan, the drone will move through a series of steps:

1. Skydio will continue scanning and trying to reconnect. If it doesn't reconnect in 60 seconds, the drone will return to the Rally Point during a 3D Capture or a Surface Capture.
2. If it still doesn't reconnect in the next 30 seconds, the drone will return to the Launch Point.

Low Battery

When the drone reaches a low battery level (about 3 minutes of flight time remaining), it will automatically return to the Rally Point. If no Rally Point is set, your drone will automatically return to the Launch Point.

You will then be prompted to land. If the battery reaches a critical level the drone will auto-land.

You may pause this autonomous action at any point using the left shoulder button on your controller.

If you are manually piloting the drone when it reaches a low battery level, Skydio will land in place.

Environmental Factors

Precipitation



WARNING: Flying in precipitation with Skydio X10 requires obstacle avoidance to be disabled. Skydio 3D Scan cannot safely operate without obstacle avoidance. **Scanning is unavailable in precipitation.**

General

- Skydio does not recommend flying X10 in gusts at or above 28 mph (45 km/h), or in temperatures less than -4°F (-20°C) and more than 113°F (45°C).
- If it is too hot or too windy, the drone will return to the scan start point. You then have the option to take over and pilot it home.
- One factor of a successful reconstruction is consistency between images. When White Balance is set to Auto, the value is locked based on the first image of the scan. If you manually set a specific White Balance value, this will be used throughout the scan. Lower values result in a cooler (blues) image while higher values result in a warmer (yellows) image.

For the Skydio X10 Operator Manual, visit skydio.com/manuals.

