

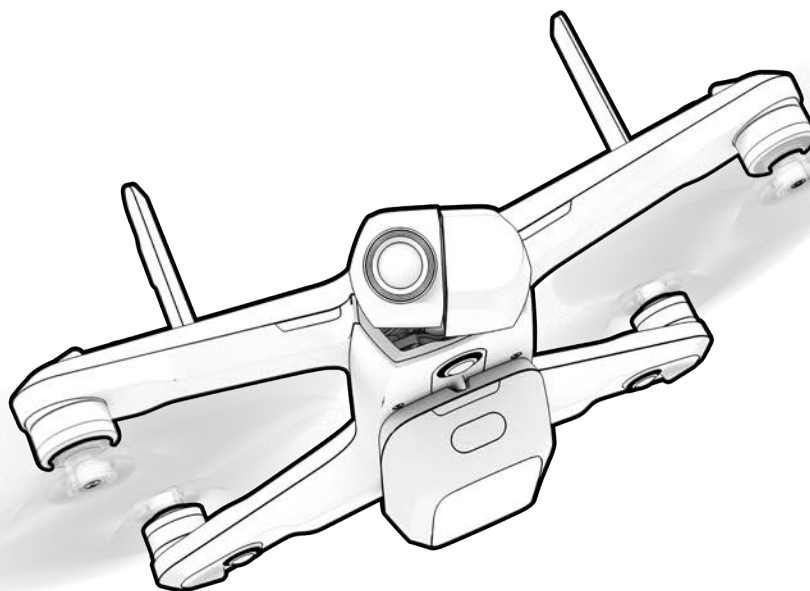

Operator Manual

Skydio 2/2+ Enterprise



WARNING: Please read all documentation provided with your Skydio 2/2+ including but not limited to the Safety & Operating Guide found here: <http://skydio.com/getstarteds2e>



Last updated: January 4, 2022

Contents

Overview

Skydio 2/2+ and Accessories.....	1
Skydio 2/2+ Hardware.....	2
Skydio Autonomy Enterprise.....	3

Safety

Safety Guidelines	4
Flying Safely.....	5

Pre-flight

Set Up.....	6
Charging Skydio 2/2+	6
Activate Enterprise app.....	7
Settings menu.....	8
Drone settings menu.....	8-11
Phone settings menu.....	12
Controller settings menu.....	13
INFO menu.....	14
Overwrite Media.....	14
Return To Home	15
Maps.....	16-17
Pre-flight Inspection.....	18

Flight

First flight.....	19
Launch	19-20
Flight screen.....	21
Camera and Video	22
Zoom.....	23-24
Battery Indicator.....	25
Flight Skills.....	26
Manual Skill	27
Orbit Point Skill	28
Track In Place Skill	29
Waypoint Skill.....	30-31

Contents

Cinematic Skills	32-33
One-Shot Skills.....	34
Land.....	35-37
Post-flight	
Reviewing and offloading media	38
Emergency Behaviors	
Lost connection.....	39
Lost GPS.....	40
Low battery	40
Lost drone.....	41
Maintenance	
Batteries	42
Replace propellers	43
Updates	44
Specifications	45 - 50
Legal	51

Overview

Skydio 2/2+ and Accessories



Skydio Pro Kit includes:



- Skydio 2+ batteries (3)
- Skydio 2+ Beacon (3)
- Bacon batteries (3)
- Joystick Controller
- Controller tablet adapter
- Dual Charger
- Pro Case
- Soft case
- SD Memory Cards pre-installed
- PolarPro ND filter set
- Spare propellers
- Skydio Care

Overview

Skydio 2/2+ Hardware

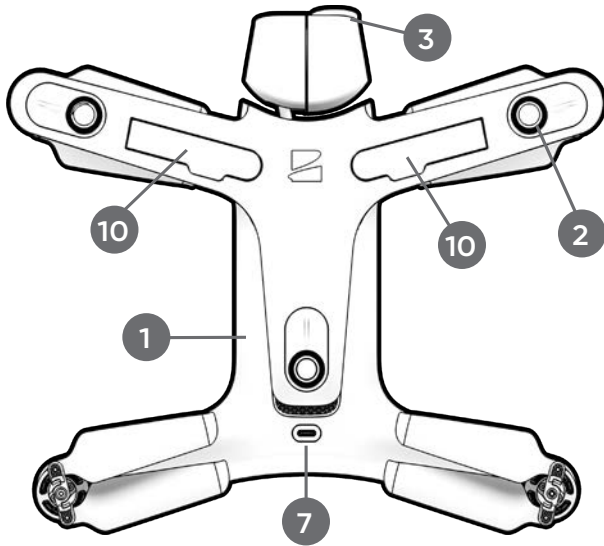

Top view

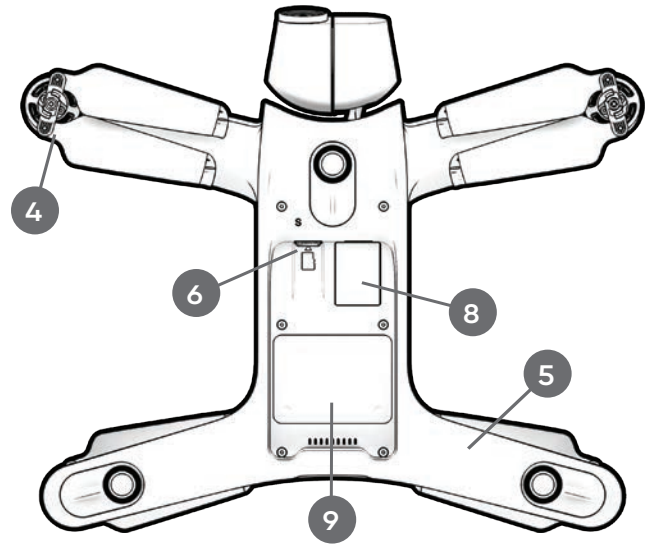

Bottom view

- | | |
|--|-------------------------------|
| 1. Chassis | 6. MicroSD memory card port |
| 2. Navigation camera (6)
3 on top and 3 on bottom | 7. USB-C port |
| 3. Subject camera | 8. Battery tray |
| 4. Propeller hub with blades | 9. Vehicle ID and password |
| 5. Arm (4) | 10. Antennas (Skydio 2+ only) |



CAUTION: Skydio 2/2+ is not weatherproof. Do not operate in any precipitation, including rain, fog, snow, or similar environments. Do not rest in sand, dirt or on similar terrain where particles can get trapped in the fan.

Skydio 2/2+ Control Options

Beacon



Controller



Smartphone

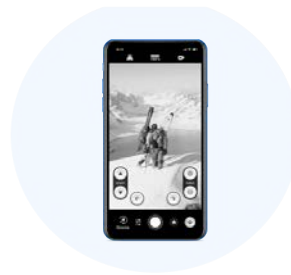

Overview

Skydio Autonomy Enterprise Features

FEATURE	DESCRIPTION	KEY BENEFITS
Close Proximity Obstacle Avoidance	Fly closer to obstacles. Standard (~34") Close (~11") Minimal (~4") Disabled	Allows for indoor navigation and up-close inspection of detailed assets
Precision Mode	Tunes the system for ultra-precise positioning of the drone based on joystick inputs.	Allows for up-close photography and effortless capture of critical components
Visual Return-to-Home	Allows visual return to home wayfinding when flying in GPS denied environments	Provides robust and safe returns in high-RF or GPS denied environments
Offline Maps	Download maps to use map-based features without a cellular LTE connection	Use map-based functionality even for jobs in remote, off-the-grid areas
Superzoom	Blends the six 4K navigation cameras to create an omni-directional view. Allows the user to zoom digitally with algorithmic image stabilization	See farther, and in all directions without moving the drone - reduces pilot cognitive load
Point-of-Interest Orbit	Drone will navigate itself while revolving around a user-defined point on a map	Enables surveillance and over-watch of any structure or locale
Track-in-place	Ability to visually track a car or person from a fixed position from farther away	Enables covert surveillance from farther standoff distances
Vertical View	Gimbal can look straight up overhead of the drone	Allows for overhung inspections such as ceilings, bridges, and canopies

Safety

Safety Guidelines



Keep your fingers away from moving propellers at all times.

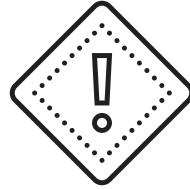

Use caution around reflective surfaces (still water, mirrors, etc.) and small obstacles (thin branches, utility lines, ropes, chain link fencing, etc.)

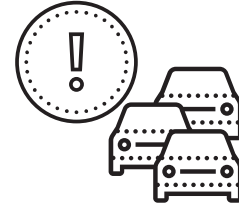

Skydio 2/2+ does not avoid moving objects or cars.



Skydio 2/2+ is not weatherproof – don't fly in rain, snow, fog, high winds, etc.

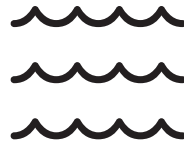

Before flying over water, ensure your drone has GPS lock. Launch and land your drone over a dry surface.

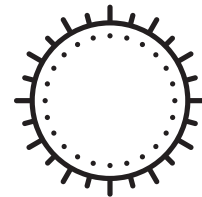

Don't fly in low-light conditions or in poor visibility



Clean all of the cameras so Skydio 2/2+ can see clearly.

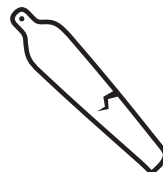

Check your propellers for damage before flying.



Follow all civil aviation authority regulations, as well as any applicable local and federal laws

Safety

Flying Safely

Pre-flight

- Ensure that all of the camera lenses are dust and smudge-free prior to flight
- Inspect the battery magnets and connections for damage and debris prior to flight
- Inspect propeller blades for nicks, cracks, or other visible damage prior to flight
- Inspect the chassis for damage and debris prior to flight

Environment

- Do not fly in precipitation, fog, or snow
- Ensure flight environment has good visibility
- Do not fly in extremely hot temperatures above 104°F (40°C)
- Do not fly in extremely cold temperatures below 23°F (-5°C)
- When flying in temperatures below 32°F (0°C) ensure your batteries are pre-warmed to 50°F (10°C) prior to takeoff
- Avoid windy weather conditions, or gusts above 25 mph (40 km/h)
- Do not fly over bodies of water more than 30 ft (3 m) across
- Do not fly around objects less than .5 in (1.27 cm) in diameter such as thin branches, utility lines, ropes, netting
- Do not fly around objects in motion such as cars, boats, balls, animals, or other drones

Warnings

- Fly cautiously around people
- Avoid transparent or reflective surfaces, windows, or mirrors greater than 23 in (58 cm) wide
- Avoid moving obstacles, cars, and animals
- The pilot in command (PIC) is responsible for managing altitude, range, and battery level and monitoring in-app messages and alerts
- Avoid flight in low-light conditions
- Alert messages will display if Skydio 2/2+ determines the environment is not safe for flight
- When instructed to do so, immediately fly Skydio 2/2+ to the safest area and land
- Flying at high altitudes may significantly increase the time required to return and safely land
- Propeller blades are sharp—handle with care
- Skydio should not be used or handled by a person under the age of 18 years

Regulations

- Follow all civil aviation, such as the FAA or your countries regulatory agency, rules and regulations
- You are responsible for your Skydio 2/2+ at all times. When operating your Skydio X2 check knowbeforeyoufly.org / B4UFLY / CASA-verified before flying.
- Keep your Skydio drone within visual line of sight at all times, unless you have received express permission to fly beyond visual line of sight from a civil aviation authority such as the FAA.
- Do not fly in an environment where the use of the device is not authorized or restricted.



INFO: Visit <https://skydio.com/safety> and <https://skydio.com/support> for more information, helpful tips, videos, and articles.

Pre-Flight

Set-Up

Step 1 - Insert a micro SD card into the memory card slot

- you may be required to format your card in the drone before flying
- Skydio 2/2+ will not fly without a properly formatted card

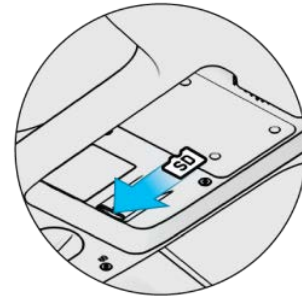

Step 2 - Attach the battery to your Skydio 2/2+

- the batteries are held in place with magnets
- firmly tug battery to remove

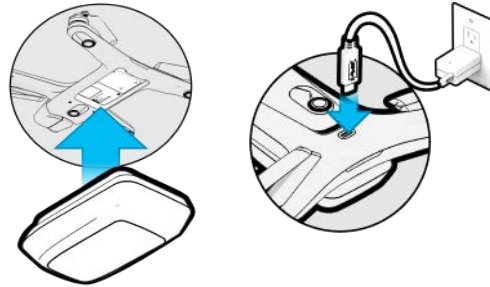

Step 3 - Charge your battery using the USB-C cable and power adapter

- charge in an open area
- it is normal for the drone and battery to be warm during charging



Charging

Battery lights indicate the current state of charge

- lights will pulse while the battery is charging
- lights will remain solid for one minute and turn off when charging is complete



Fully Charged

Step 4 - Deploy antennas (Skydio 2+ only)

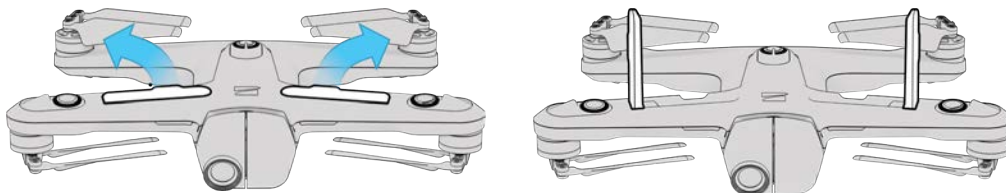

Pre-Flight

Activate Skydio Enterprise app

The Skydio Enterprise app on your mobile device is used to fly your Skydio 2/2+, update your system, format your SD memory card, view and manage your media.



Step 1 - Install the Skydio Enterprise app on your mobile device:

- available on the App Store® and Google Play
- compatible with iOS 12.0 or Android 9.0 (or later)

Step 2 - Launch the Skydio Enterprise app

Step 3 - Enable location and microphone settings on your phone

- and local networking on iOS

Step 4 - Power on your Skydio 2/2+

- press and hold the battery button for 3 seconds

Step 5 - Activate your Skydio 2/2+

- Skydio will email you a unique registration code

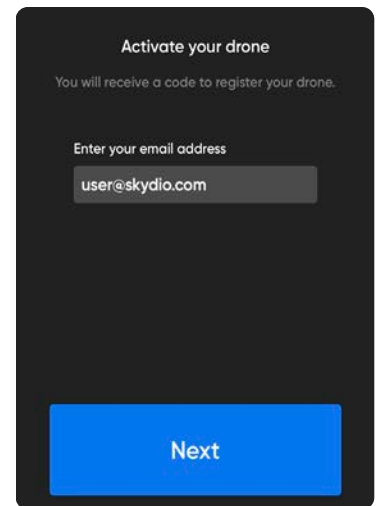

Step 6 - Enter the code sent to your email

- select **Next**

Step 7 - Enter your Skydio 2/2+ WiFi name and password when prompted

- located on the sticker attached to the drone or inside the battery tray
- remove the sticker attached to the drone before flying

Step 8 - Check for updates

- Skydio Enterprise app will guide you through the process

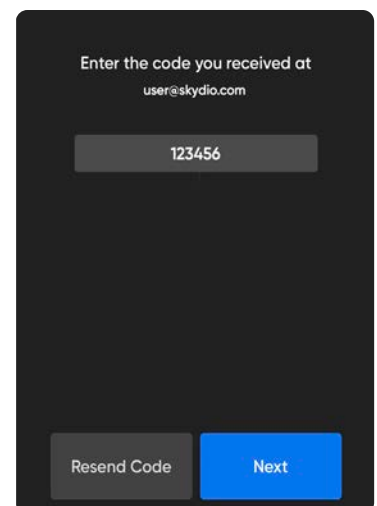

Pre-Flight

Settings Menu

Access in-flight settings for the drone, your phone, and the controller (if connected).

Drone Settings Menu

Height Limit

Height Floor - (enabled by default) maintains at least 8 ft (2.4 m) of space above a tracked subject while in any autonomous follow skill, creating a buffer between Skydio 2/2+ and any moving objects, such as people, pets, or vehicles.

While following a subject, Skydio 2/2+ may become trapped by obstacles and unable to continue following due to the height restriction, even though the space underneath the drone is clear.

You will be unable to lower the Height Floor below 8 ft (2.4 m) height floor while tracking a subject.

Disabling the Height Floor setting may increase tracking performance by allowing Skydio 2/2+ to fly under low-lying obstacles, such as tree branches and overhangs, to maintain a visual line of sight. It also allows users to set the preferred follow height low to the ground, capturing high-energy shots from a unique ground-hugging perspective.

Skydio 2/2+ only avoids obstacles that are not in motion. Cars, balls, animals, other drones, other people, or similar moving objects will not be avoided if they're moving faster than walking speed.

The combination of low elevation flight and high-speed tracking presents an increased risk of collision with moving objects. Skydio strongly recommends users only disable the Height Floor setting when operating in wide open, outdoor spaces with no other people, animals, or other moving objects nearby. Pilots maintain full responsibility for the safe operation of their Skydio 2/2+ drone at all times during the flight.

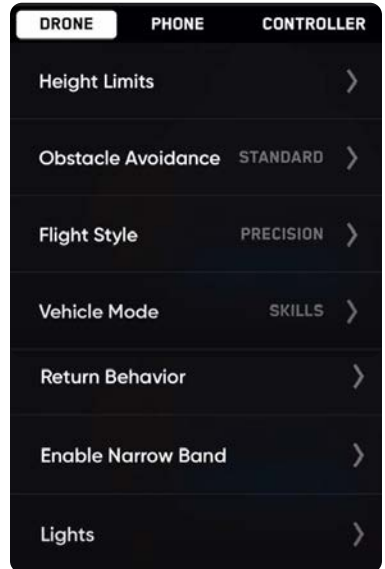

NOTE: the Height Floor setting only applies while a subject is being tracked. If Skydio 2/2+ is in manual flight mode with no subject selected, you always have full control over the drone's height.

Height Ceiling

- adjust the maximum allowed flight ceiling height to between 30 and 1500 ft (10 and 457 m)
- disable the height ceiling for a maximum allowed flight altitude

Indoor Height Ceiling

- (enabled by default) prevents you from flying above 66 ft (20 m) when your drone does not have access to GPS and cannot see the sky
- Disabling the Indoor Height Ceiling setting does not persist across flights or power cycles



Pre-Flight

Drone Settings Menu

Obstacle Avoidance - allows for navigation through tight spaces and up-close inspection of detailed assets. Select the obstacle avoidance mode that best suits your environment:

- **Standard:** 34 inches (86 cm) between your Skydio 2/2+ and any obstacle
the top airspeed is 36 mph (58 km/h)
- **Close:** 11 inches (28 cm) between your Skydio 2/2+ and any obstacle
the top airspeed is 9 mph (14.5 km/h)
- **Minimal:** 4 inches (10 cm) between your Skydio 2/2+ and any obstacle
the top airspeed is 9 mph (14.5 km/h)
- **Disabled:** obstacle avoidance is disabled
the top airspeed is 9 mph (14.5 km/h)



WARNING: Flying with Close, Minimal or Disabled obstacle avoidance settings greatly increases risk of collision. Minimal or Disabled obstacle avoidance settings are used to navigate tight spaces and should only be used if you are an experienced pilot. Skydio recommends turning down Controller throttle, roll and pitch sensitivity to the lowest setting and proceeding at a max speed of 2 mph (3 m/s).

Pre-Flight

Drone Settings Menu

Flight Style

Determines the way Skydio 2/2+ moves in flight. Precision tunes the Skydio 2/2+ system for ultra-precise control and positioning, while Cinematic results in smoother movement that is optimized for more stabilized video. Precision flight style is selected by default.

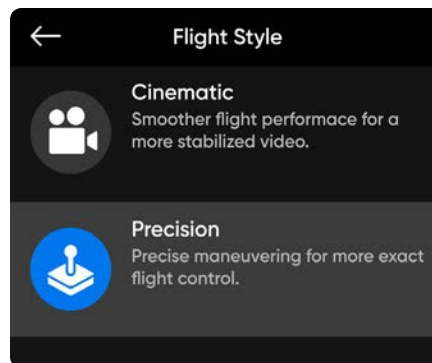

Customize Skydio 2/2+ return behaviors:

Return Type - return using GPS or the vision navigation system

Visual return for flight in GPS denied environments.

- requires returning to the Launch Point. Flying to a set Home Point or to your Phone will require GPS.
- reference the table below to see how Skydio 2/2+ returns based on Return Type.

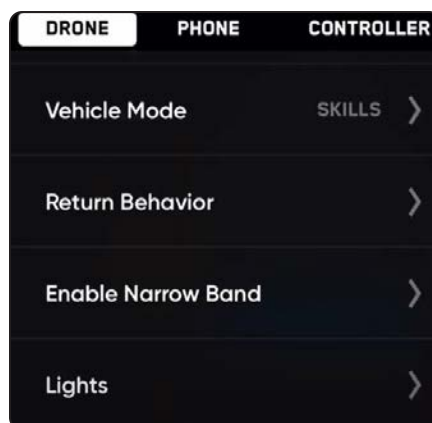

	RETURN TYPE = GPS	RETURN TYPE = VISION
LAUNCH POINT	Skydio 2/2+ will use GPS to return to launch point	Skydio 2/2+ will use visual navigation to return to launch point
PHONE	Skydio 2/2+ will use GPS to return to phone location	Not supported in visual navigation. Skydio 2/2+ will use GPS to return to phone location
HOME POINT	Skydio 2/2+ will use GPS to return to home point	Not supported in visual navigation. Skydio 2/2+ will use GPS to return to home point
FLY HERE NOW	Skydio 2/2+ will use GPS to fly to specified location	Not supported in visual navigation. Skydio 2/2+ will use GPS to fly to specified location

Pre-Flight

Drone Settings Menu

Return Height - Set the height to which Skydio 2/2+ should ascend before returning. By default the return height is set to 32 ft (9.7 m) Skydio 2/2+ will ascend to that height before returning.

Height Behavior

- **Absolute** - ascends to the specified Return Height **above the launch point** before returning. For example, if the Return Height is 32 ft and the drone is at 20 ft at the time the return is commanded, Skydio 2/2+ will ascend 12 ft before returning.
- **Relative** - ascend to the specified Return Height **above the current position** before returning. For example, if the Return Height is 32 ft and the drone is at 20 ft at the time the return is commanded, Skydio 2/2+ will ascend 32 ft and then return at a height of 52 ft.

Return Speed - Set the speed at which Skydio 2/2+ should fly when returning.

Drone Looks - Skydio 2/2+ will either look toward or away from the return destination while returning.

Lost Connection -

- **Return when Disconnected** - toggle Off to disable Return when Disconnected and the Lost Connection menu. Skydio will not return if it loses connection—it will hover until it reaches low battery and land.
- **Wait Before Return** - set the amount of time that you want Skydio 2/2+ to wait before it initiates a return flight, allowing time to reconnect.
- **Land Once Returned** - when enabled, Skydio 2/2+ will return, hover for a specified amount of time, and then land.
- **Wait Before Land** - set the amount of time between 0 to 300 seconds (the default is 240 seconds) that you want Skydio 2/2+ to wait before landing. This setting is only enabled when **Land Once Return** is toggled on.

Enable Narrow Band: change your radio frequency to a narrower band

- Enable Narrow Band to provide an additional wireless range
- extends controller range in open environments
- when enabled, the drone will switch to narrow band whenever applicable
- the video quality may suffer slightly



NOTE: You should only enable the narrow band to extend control range when in open and clear environments and when you have a clear line of sight.

Lights

- Enabled - RGB navigation lights display red when the drone is facing you and green when facing away to help you quickly understand the orientation of your drone.
- Disabled - RGB navigation lights will be on during the initial boot sequence and will turn off when the drone is ready to fly.

Pre-Flight

Phone Settings Menu

App Controls

- slide (default) – Single stick with pitch and roll with yaw on separate buttons
- steering – Single stick with pitch and yaw with roll on separate buttons
- Dual Sticks – Traditional Mode 2 dual-stick controls

Dual Sticks Mode

- sets the control style for the Dual Sticks app control setting. Allows you to choose between Mode 1, Mode 2 (default), and Mode 3 style controls

On Screen Display

Coordinates – when viewing your maps, creating waypoint missions, or orbiting a point of interest, you can view latitude and longitude coordinates for the position of Skydio 2/2+, the Controller, Home Point, and Fly Here Now on the map in real-time.

- disable this setting if you do not want coordinates displayed
- the selection will persist across flights and power cycles

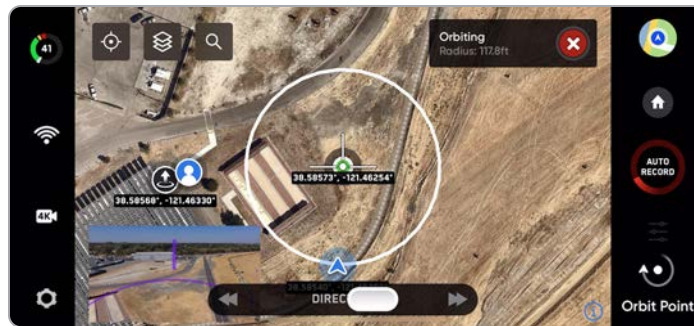
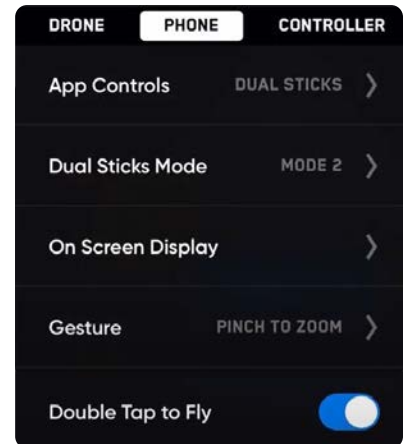

Telemetry

- toggles the display of vehicle telemetry data
- when enabled, Skydio 2/2+ current speed, height above launch, range from the launch point and the camera angle (gimbal pitch) is displayed while in flight

Gesture

- select whether pinch gestures control flight or zoom

Double Tap to Fly

- toggle Double Tap to Fly on or off

Pre-Flight

Controller Settings Menu

Gimbal Speed

- controls how quickly camera gimbal pitches up and down

Flight Sensitivity

- switch between default and custom sensitivity settings for the roll, pitch, yaw and throttle inputs
- default settings are fixed and cannot be changed
- custom settings may be adjusted



Flight Mode

- switch between Mode 1, Mode 2 (default), and Mode 3 style flight controls



NOTE: Controller settings are only available when your Controller is connected to your drone.

Return to Home

The Return to Home icon gives you the ability to have Skydio 2/2+ automatically return to either the launch location or your current location. Create a Home Point (or move the existing Home Point) by long-pressing on the map and selecting Set Home Point from the menu.

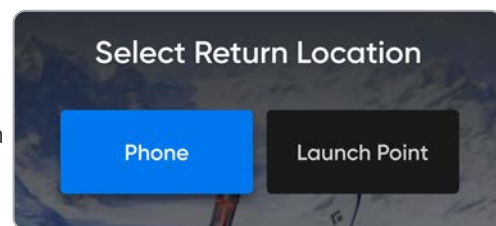

Home points are optional, set for each flight and not saved between flights. Skydio 2/2+ will automatically return to a set Home Point in the event of a loss of communication (unless otherwise specified in the waypoint settings). Tapping on a Home Point on the map gives you the option to fly the drone to that location immediately or remove it from the map.



NOTE: Skydio 2/2+ must have a GPS signal at some point during the flight to create a Home Point. The better and more sustained the GPS signal, the more accurate Skydio 2/2+ flight will be when returning to that Home Point. If Skydio 2/2+ loses GPS or the GPS signal becomes weak, the drone will do its best to estimate and return to the Home Point position.

Pre-Flight

INFO Menu

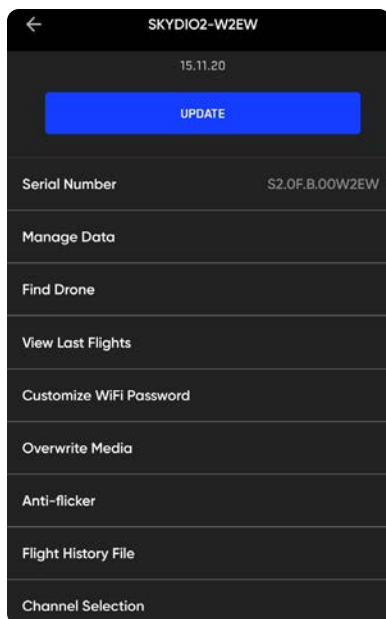

Manage Media

Select to format media card if Skydio Supports requires you to perform a Factory Reset

Find Drone

In the event that your Skydio 2/2+ is lost, you may view its last known location. If the Coordinate setting is enabled, the latitude and longitude of the current or last known location will be displayed, making it easier for you to locate your lost drone.

View Last Flight

The View Last Flights feature is designed to assist you with locating your drone in the event of a crash, emergency landing, or low battery landing in an unintended location:

Customize WiFi Password

Change your WiFi password or reset a changed password back to the factory-generated credentials.

- set personal password or set length and Auto Generate a password
- you will be prompted to reconnect to your Skydio 2/2+ using your new credentials

Overwrite Media

You can manage your media storage space by automatically deleting old media to ensure that you always have enough storage space to start a new flight without waiting. Toggle this setting on to automatically delete the oldest media stored on the SD memory card.

Step 1 - Select the **INFO** menu

Step 2 - Select your drone name

Step 3 - Select **Overwrite Media**

- toggle on to automatically delete the oldest media stored on the SD memory card
- the setting will persist across flights and power cycles

Pre-Flight

INFO Menu

Anti-flicker

Adjust anti-flicker settings if you experience flickering in your video. This setting is for users located outside of North America, in countries where the frequency of the alternating current in household electrical outlets is 50 Hz.

Step 1 - Select the **INFO** menu

Step 2 - Select your drone name

Step 3 - Select **Anti-Flicker**

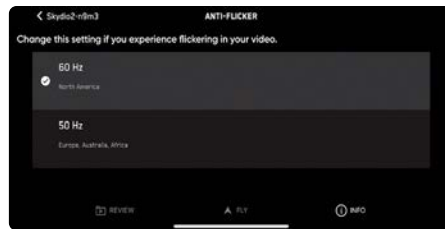

Flight History File

Save flight data to a flight_history.csv file on the media card containing the following flight data:

- Vehicle name
- Flight ID
- Launch latitude/longitude and time
- Land latitude/longitude and time

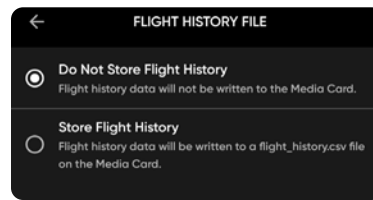

Channel Selection

Manually select your radio frequency channel to avoid congestion from other signals. These are standard 5 GHz WiFi channels that correspond to the following frequencies:

- 36: 5180 MHz
- 40: 5200 MHz
- 44: 5220 MHz
- 48: 5240 MHz
- 149: 5745 MHz
- 153: 5765 MHz
- 157: 5785 MHz
- 161: 5805 MHz
- 165: 5825 MHz

Skydio recommends leaving Channel Selection set to Auto for best results.



Pre-Flight

Maps

Select the map icon to enter the map view. Your location, Skydio 2/2+, and Skydio 2/2+ launch location are all indicated on the map. To exit the map view, tap the map icon again.



Skydio 2/2+



Controller/
Phone



Home Point



Launch Point



Beacon



Map Coordinates - When viewing your maps, creating waypoint missions, or orbiting a point of interest, you have the option to view latitude and longitude coordinates. The position of Skydio 2/2+, the Controller, Home Point, and Fly Here Now will display coordinates on the map in real-time.

Disable this setting if you do not want coordinates displayed

Step 1 - Select the **Settings** menu

Step 2 - Select the **Phone** tab

Step 3 - Select **On Screen Display**

- toggle off
- your selection will persist across flights and power cycles

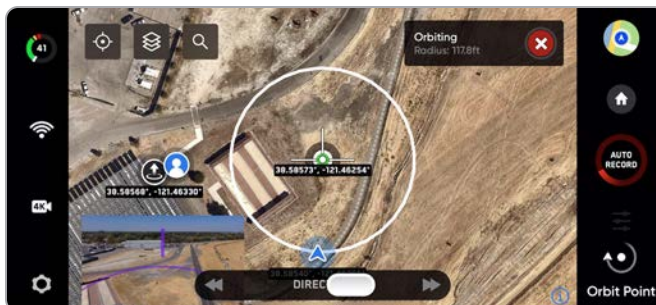

Pre-Flight

Maps

If you are going to be flying in an LTE-denied environment, you can cache a map region in advance and fly completely offline. To download maps:

Step 1 - Ensure that you have Internet access

Step 2 - Launch the Skydio Enterprise app

Step 3 - Select the **Info** menu

Step 4 - Select **Download Maps**

Step 5 - Select the **+** icon under **Add New Map**

- a satellite view of your current location will display
- drag and pinch-to-zoom on the map until your desired location is centered on the screen

Step 6 - Select **Download Map**

- the map will be 3.5 x 3.5 square miles, centered around the target point even if you are zoomed in

You can save up to 10 maps at a time in the Skydio Enterprise app. To make room for more you will need to remove existing maps:

Step 1 - Launch the Skydio Enterprise app

Step 2 - Select the **Info** menu

Step 3 - Select **Download Maps**

Step 4 - Tap **Select** in the upper-right of the screen

Step 5 - Select one or multiple maps

Step 6 - Select **Delete**

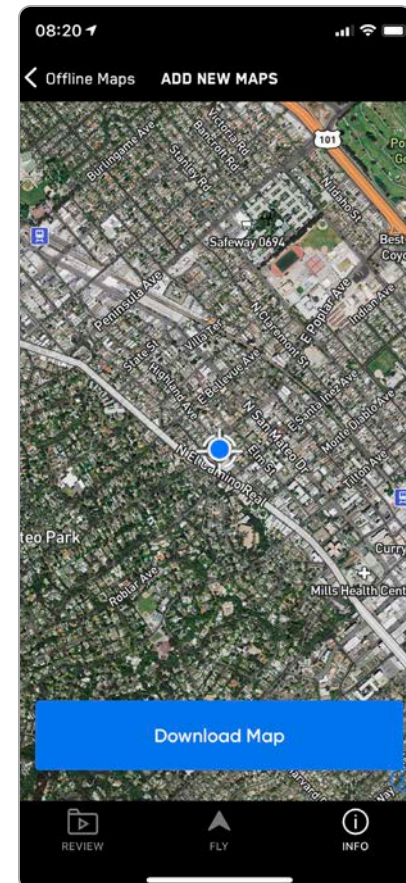
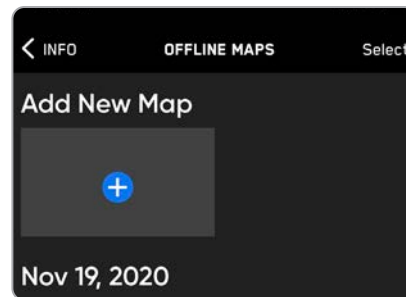

NOTE: The map library is able to store 10 maps at a time. Delete unused maps to make room for new maps.

Pre-Flight

Pre-flight Inspection

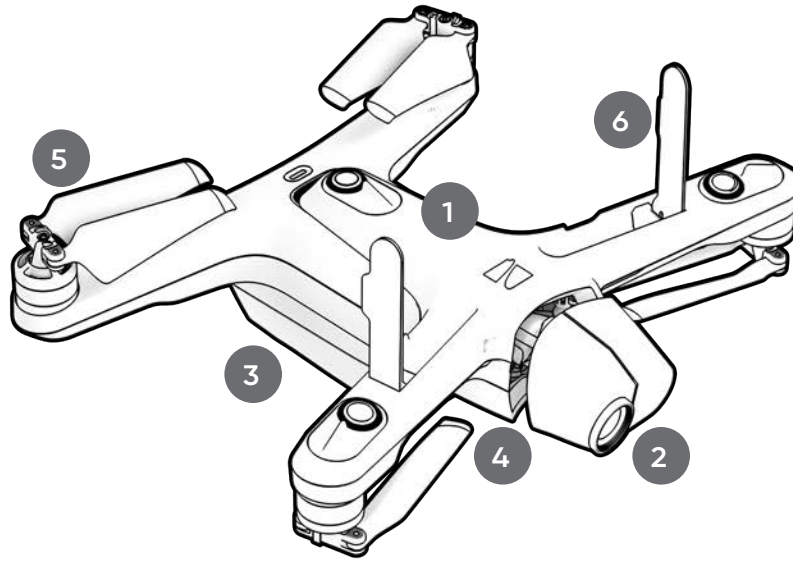

1. Inspect the body

- to ensure it is free of damage

2. Clean the camera lenses

- Skydio 2/2+ navigates visually, so it is essential to keep the camera lenses clean
- use a clean microfiber cloth to remove dust and smudges before every flight

3. Inspect the battery

- Skydio 2/2+ uses magnets to seat the battery which may attract metallic debris that could interfere with the seating of the battery
- visually inspect the battery, tray, and connection pins, to ensure that they are free of debris or damage
- verify the battery is fully seated prior to takeoff

4. Remove the gimbal clip

- remove the gimbal retaining clip from the front-facing camera before flight
- the gimbal will be slightly askew—this is normal behavior, and once in the air the gimbal will align itself
- reinsert the gimbal clip after flight

5. Inspect the propeller blades

- ensure that the propellers are firmly attached and free of nicks, cracks, or other visible damage
- do not fly with damaged propellers

6. Inspect the antennas (Skydio2+ only)

Flight

First flight

Before you begin your first flight, please read and follow all of the safety guidelines <https://skydio.com/safety>.

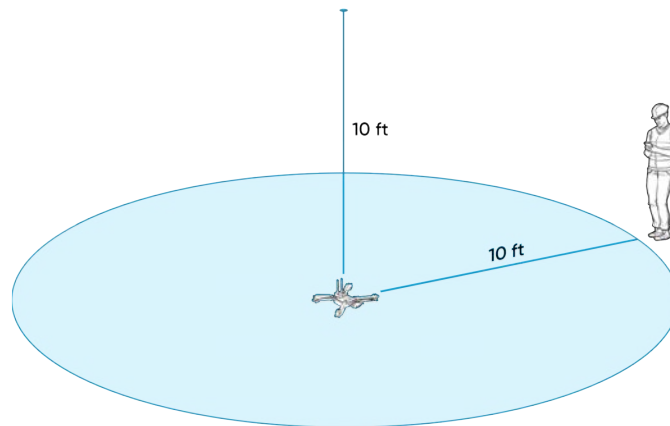

Launch

Step 1 - Find a clear area to launch

Step 2 - Place Skydio 2/2+ on a flat, stable surface

Step 3 - Select **Launch** on the Fly screen or Press and hold the **Launch/Land** button on the Controller

- Skydio 2/2+ will ascend to 10 ft (3 m) and hover in place until you initiate a Skill or fly manually



NOTE: Skydio 2/2+ requires a stable GPS connection for outdoor flight at an altitude greater than 33 ft (10 m) above its point of takeoff or the currently tracked subject. This may not be possible when flying in GPS denied environments such as indoors, heavy urban areas, and deep canyons; or when flying near large metal structures such as radio towers and bridges. Fly a few meters in a lateral motion (forward, backward, left, or right) to acquire a GPS lock. The indoor height ceiling is 66 ft (20 m) and can be toggled off.

Flight

Hand Launch



WARNING: Launching and landing Skydio 2/2+ from your hand is an advanced maneuver only to be used when it is necessary, and it is advised that you do so only if you are an experienced pilot. Exercise extreme care to avoid injury if the drone takes off from your hand. To avoid injury stay away from and do not touch rotating propellers when they are spinning. See safety guidelines at <https://skydio.com/safety>.



Step 1 – Find an open area to launch, with clearance of 10 ft (3 m) above, 15 ft (4.5 m) in front, and 3 ft (1 m) on either side

- do not hand launch on windy days. If there is any wind, for your safety ensure that it is not blowing towards you. If the wind is gusty or coming from different directions, consider a ground launch

Step 2 – Lightly grip the battery keeping your fingers below the chassis and away from the propellers at all times

Step 3 – Point the camera away from you

- hold Skydio 2/2+ at arm's length from your body, level and still
- ensure that the rear propellers will not make contact with your arm

Step 4 – Initiate a launch using the controller Launch/Land button

Step 5 – Release Skydio 2/2+ carefully as the propellers begin to spin by slowly relaxing your grip.

- keep your hand still – Skydio 2/2+ will slide off your palm and take flight on its own
- do not push or throw the drone up in the air

Acquire GPS Lock

Immediately after launching, fly laterally to acquire a GPS lock. This is a critical step that must be taken if you are going to fly your drone over water.

- If you can fly your Skydio 2/2+ 33 ft (10 m) above ground level when outdoors you have acquired a GPS lock

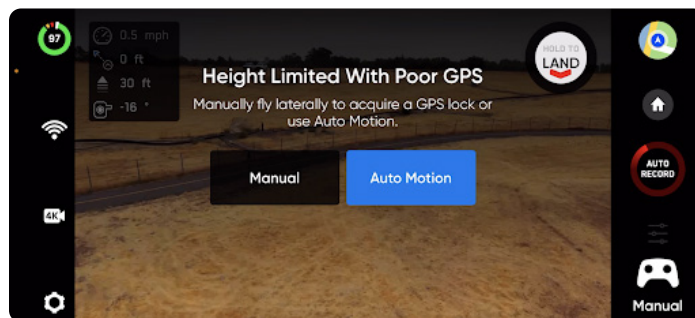

WARNING: Failure to acquire GPS lock prior to flight over water may result in erratic flight and/or emergency landing.

Flight

Flight Screen

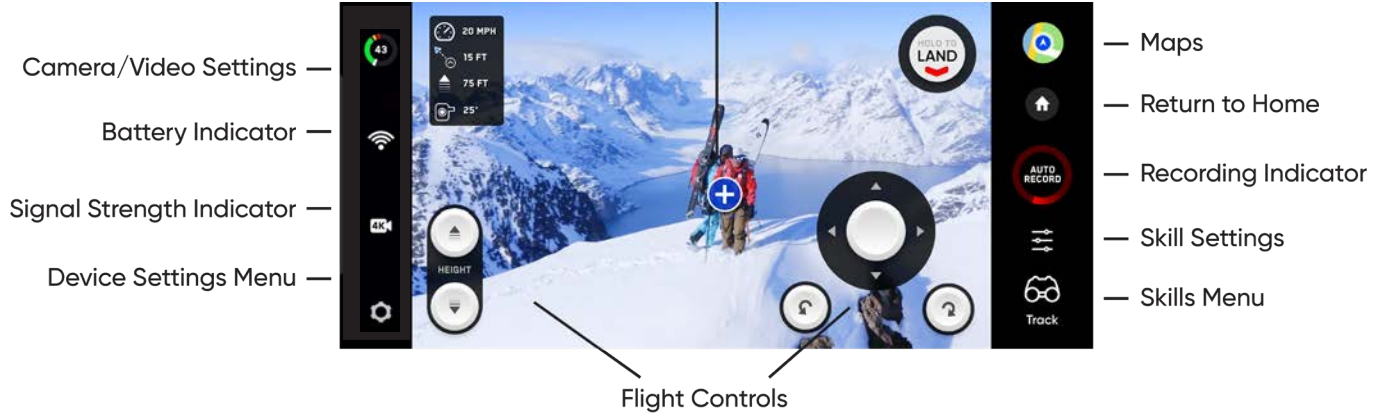

Flight Controls

The on-screen flight controls are the primary method for controlling Skydio 2/2+ during both autonomous and manual flight. Autonomous controls are unique for each skill. Manual flight controls are the same in all skills and may be customized.



Flight

Camera / Video Settings 4K

Provides access to the camera settings and allows you to change between video and photo recording mode. Skydio 2/2+ can capture photos or video but not both at the same time. You may change your camera settings at any time before or during flight.

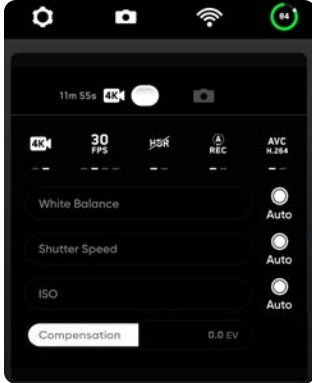

Video Capture Settings

- Resolution
- Frame rate
- HDR On/Off*
- Auto / Manual Recording
- Video Codec**
- White Balance
- Shutter Speed
- ISO
- Exposure

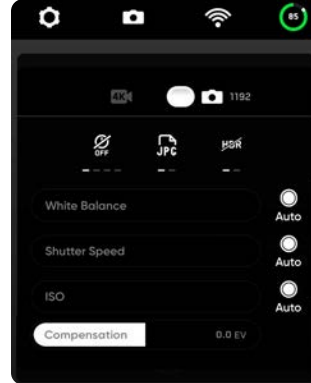

Photo Capture Settings

- Photo Interval***
- Off / 1s or 2s**** / 5s / 10s
- HDR On/Off
- JPG / JPG+DNG*****
- White Balance
- Shutter Speed
- Exposure



NOTE: Digital 3x zoom is not supported in all video resolutions and frame rate. Changing the camera settings before launch may cause Skydio 2/2+ to return to the preflight screen and re-calibrate the vision system. Some video capture settings (such as video resolution and frame rate) cannot be changed while the drone is actively zooming.

Recording Indicator



Recording Video: Auto

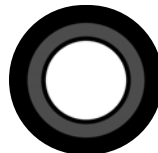

Photo Button



Recording Video: Manual



Interval Photos

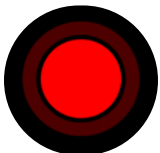

Recording Paused: Manual

* HDR is not supported in all video resolutions and frame rates.

** Skydio 2/2+ can record video in either AVC (H.264) or HEVC (H.265). Different mobile devices and personal computers have different compatibilities with these encoding standards. Be sure to choose the encoding standard that is best suited to your desired workflow.

*** When Photo Interval is enabled Skydio 2/2+ will continuously capture photos at the specified time interval until the setting is disabled or the flight ends.

**** The fastest interval photo setting when capturing in raw DNG is two seconds. Users may capture a photo every one second when capturing in JPG mode.

***** DNG photos are not displayed in the media tab of the Skydio Enterprise app and are retrieved directly from the microSD card.

Flight

Zoom

3x Digital Zoom - Digitally zoom the live video feed up to 3x

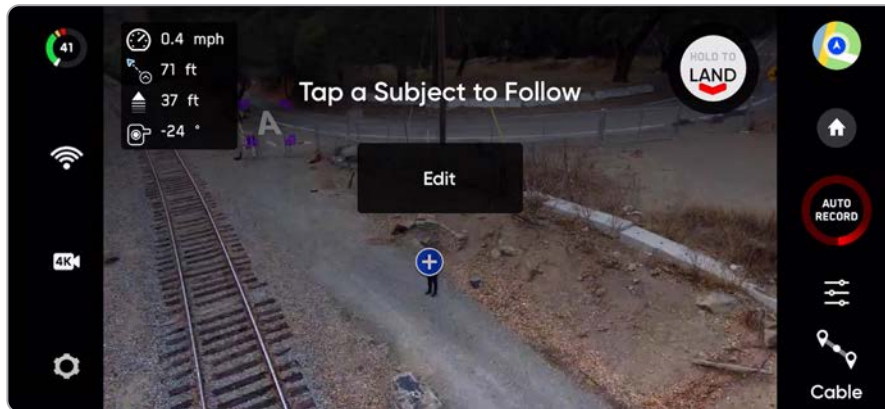

To zoom in digitally, touch two fingers on the touch screen and move them apart. If flying with the Skydio 2/2+ Controller, push the right paddle down to zoom in. Tap on the zoom indicator at the top of the screen to quickly snap back to 1x zoom (MIN).

Superzoom - You can also zoom out to an equirectangular view of your surroundings. Skydio 2/2+ uses its six, 4k navigation cameras to create this omnidirectional view in real-time, allowing you to maximize your in-flight situational awareness. Dynamic camera tilt control sensitivity while digitally zoomed-in offering smoother cinematic footage.



To zoom out to this view, touch two fingers on the touch screen and move them together. If flying with the Skydio 2/2+ Controller, pull the right paddle up to zoom out. If Skydio 2/2+ feed is already zoomed in, you will first need to zoom out to 1x before you can zoom out again to Superzoom. Tap on the zoom indicator at the top of the screen to quickly snap back to 1x zoom (MIN).



TIP: When flying with the Skydio 2/2+ Controller, pull the right paddle towards you twice in quick succession to enter Superzoom from any zoom level.

Flight

Zoom Recording Behavior and Compatibility

Video - Zoom recording behavior is set in Camera settings and Zoom settings:

- if the video is zoomed in while recording, the resulting video file will also be zoomed in.
- if video is being recorded while zoomed out to Superzoom, the resulting photos and video will remain at 1x zoom.

Photos - Zoom recording behavior is set in Camera settings and Zoom setting:

- if photos are taken while zoomed in, the resulting image will reflect the zoom level.
- if photos are taken while zoomed out to Superzoom, the resulting photos and video will remain at 1x zoom.

Video Capture Settings - While actively zooming in, the video capture settings will be locked:

- Resolution
- Framerate
- HDR On/Off
- Auto/Manual Recording
- Video Codec

To change your video capture settings, reset the zoom level back to 1x.

Compatibility - 3x Digital Zoom is not compatible with all video recording modes. To enable zoom while recording video, switch your video mode to one of the compatible modes listed below:

VIDEO MODE	ZOOM COMPATIBLE
1080p @ 30fps	YES
1080p @ 60fps	YES
1080p @ 120fps	NO
4k @ 24fps	YES
4k @ 30fps	YES
4k @ 48fps	NO
4k @ 60fps	NO



NOTE: When switching from photo mode to video mode, the zoom may be reset to 1x if the video mode you are switching back into does not support digital zoom.

Flight

Signal Strength Indicator

Displays the current strength of the signal connection to Skydio 2/2+ while in flight. As the signal strength decreases, users may experience a lower quality video feed or a delay in their controls.



NOTE: Signal strength and maximum control range may be affected when flying in areas with electromagnetic interference.

Battery Indicator

Battery indicator messaging displays how much battery is available for flight, how much battery capacity available for a return trip, and how much battery is required to land.

- Percentage - displays battery charge remaining
- Green - indicates battery capacity for nominal flight before the time limit required to safely return and land
- Yellow - indicates how much battery capacity is required to safely return
- Red - indicates how much battery capacity is required to land
- Countdown - when battery capacity has less than two-minutes of flight time available for landing the indicator will change to a countdown
- Alert symbol - when battery capacity is too low to fly the indicator will change to an alert symbol and the drone will initiate a non-cancellable landing

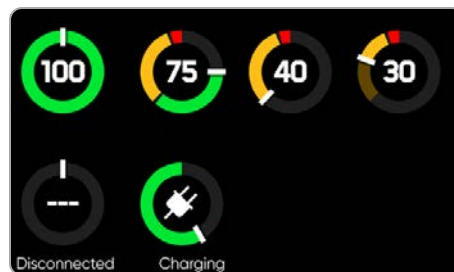

NOTE: As ground elevation and distance to home increase or decrease, Skydio takes this into account and adjusts the battery indicator accordingly.

Flight

Flight Skills

The Skydio Enterprise app offers a range of autonomous flight skills:

- General
- Cinematic
- One-Shot



Skills settings



Each skill may have its own custom settings which only affect the selected skill. Select the skill settings icon to customize each of the settings to suit your needs.

General Skills



Manual

Traditional flying experience using on-screen controls or the Skydio Controller.



Orbit Point

Rotate around a user-selected point-of-interest in either a clockwise or counter-clockwise direction, keeping the point in the center of the frame.



Track in Place

Hover in a fixed position, as if affixed to a virtual tripod, rotating and tilting the camera to look at the subject as they move.



Waypoints

Create and execute multi-waypoint GPS missions.



NOTE: Using the Beacon to perform General Skills is not supported, however Beacon will act as a range extender and allow you to control your Skydio 2/2+ up to 1.5 km away.

Flight

Manual Skill

Manual flight skill allows for a traditional flying experience with obstacle avoidance set to Standard by default.



On-Screen Controls - customize in the Device Settings menu



Slide Controls (default)

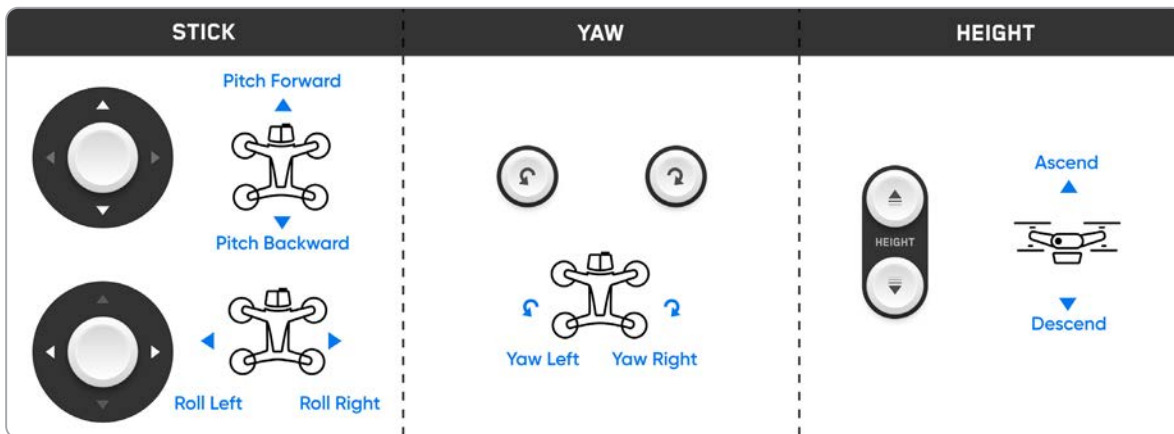

Touch Controls

- Drag vertically on-screen to increase or decrease gimbal pitch
- Drag horizontally on-screen to adjust yaw
- Pinch and drag your fingers away to digitally zoom in up to 3x
- Pinch and drag your fingers toward to zoom out to 1x or out to Superzoom
- Double-tap anywhere on the flight screen to fly directly towards that spot

NOTE: Flight Controls will not be displayed on-screen when flying with the Skydio Controller.

Flight

Orbit Point Skill

Step 1 - Select **Orbit Point** from the skills menu

Step 2 - Tap on the map view

Step 3 - Fly your Skydio 2/2+ to where the edge of your orbit will be

Step 4 - Long press on the map

Step 5 - Select **Set Focus Point**

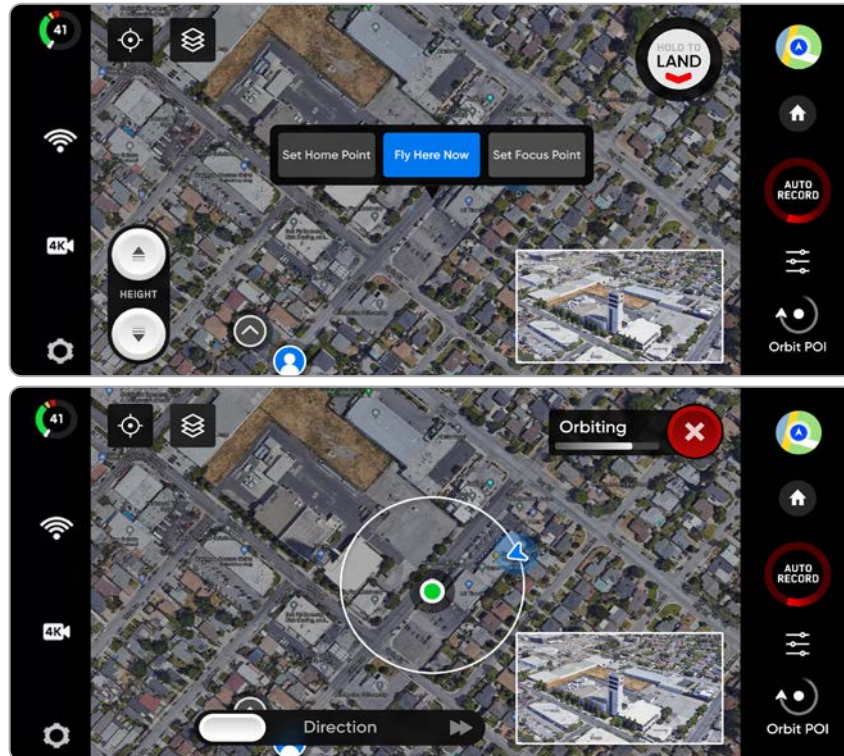

To adjust orbit settings:

- gimbal pitch and zoom use touch gestures or the Controller paddle
- speed and direction, use the on-screen slider or the Controller joystick that controls the drone's roll. Skydio 2/2+ will continue moving after lifting your finger from the screen
- to modify your orbit range, you have two options:
 1. Manually pilot the drone while in orbit. The orbit range will dynamically adjust to match the drone's pitch, roll and altitude.
 2. Pause the orbit, manually pilot the drone to a new position, then resume. Range or altitude will adjust to the drone's new distance from the Focus Point.
- to change the Focus Point tap and hold on the map and select **Move Focus Point**. This replaces the current focus point and sets the new orbit radius to match the drone's current location.



NOTE: The range of the orbit is automatically set to the current distance from the focus point.

Flight

Track in Place Skill

To visually track a subject:



Step 1 - Select the **Track In Place**

Step 2 - Identify a subject of interest

Step 3 - Fly to an area within:

- person 50 ft (15 m)
- vehicle 70 ft (20 m)



Step 4 - Select the  or  icon to lock onto the subject. The drone will then hover in place, rotating and tilting the camera to look at the subject as it moves.



While the drone is tracking a subject, use the on-screen controls or Controller joysticks to control the pitch, roll, and altitude of your drone. The drone will adjust yaw and gimbal pitch automatically according to the subject's position.

Skydio 2/2+ will hover in place and maintain a track on the subject for up to 400 ft (120 m) away if that subject is a person, and 500 ft (150 m) away if a vehicle. As the subject moves or the pilot flies the drone, tracking will continue until the subject is too far away or blocked by an obstruction.

 **Note:** lateral movement speed will be limited to 4 mph (6.4 kph)

Flight

Waypoints Skill

The Waypoints skill allows you to design and execute multi-waypoint GPS missions. Skydio 2/2+ uses AI-enabled path planning algorithms to avoid obstacles.

To create a Waypoints mission:

Step 1 - Select **Waypoints** from the skills menu

Step 2 - Select the map view

Step 3 - Press and hold on the map

Step 4 - Select **Add Waypoint**

- to set the first waypoint

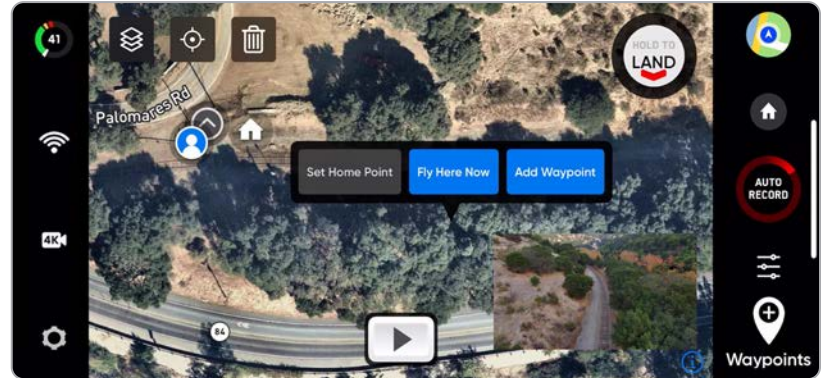

The drone's current pose settings will automatically be applied to the first waypoint. To customize these settings, **tap on the newly created waypoint** and set the drone's altitude, heading and gimbal angle for that waypoint as desired.

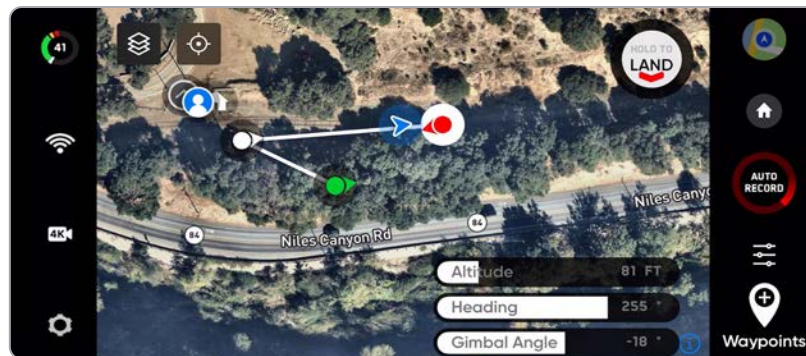

Step 5 - Press and hold on the map to set your second waypoint

- your drone's pose settings will match those of the previous waypoint
- select the waypoint to adjust the settings as needed
- continue adding waypoints until your mission path is complete
- one mission supports up to 256 waypoints

Step 6 - to delete a waypoint

- press and hold on the point and select **Delete** or
- select the **trash** icon to clear all of the waypoints

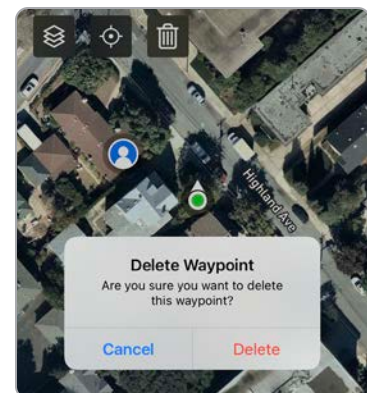

Flight

Waypoints Skill

After you have created your waypoint mission, select the Waypoint Skill settings menu  to further customize your Skydio 2/2+ behavior.

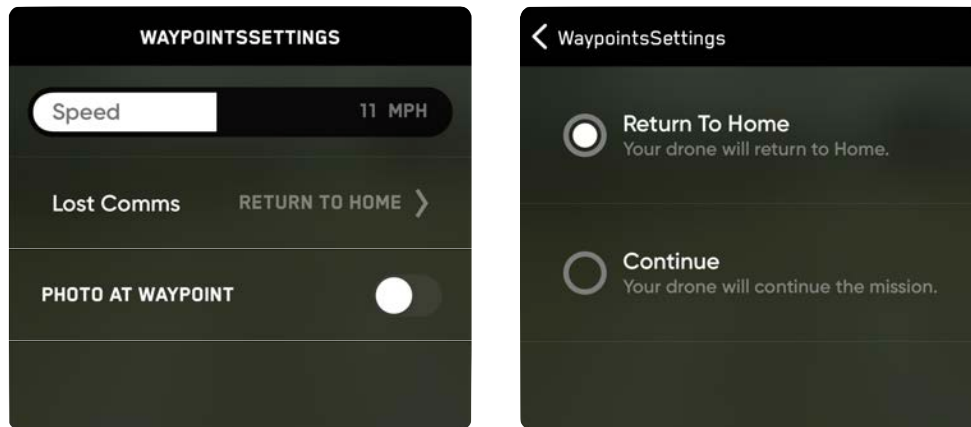

Speed - set the speed at which Skydio 2/2+ moves between waypoints

Lost Comms - set the protocol for Skydio 2/2+ to follow if the communication link is lost during a mission:

- Return to Home is the default for lost communication link
- set to continue the mission

Photo at Waypoint - when enabled Skydio 2/2+ will take a photo at each waypoint



NOTE: If the Photo at Waypoint setting is toggled on, and the drone is in Video mode, Skydio 2/2+ will automatically **switch to Photo mode** while a waypoint mission is active. The drone will switch back into Video mode upon pausing a mission, completing a mission, or exiting the Waypoints skill.

To start a mission:

Select **Play**

- Skydio 2/2+ will autonomously move through each waypoint in the mission
- when complete it will hover in place

Missions are stored on your phone and will persist across flights and reboots. However, **only one waypoint mission may be defined at a time** – you cannot save and load between multiple missions. Waypoint missions can be created and edited offline without being connected to a drone.



NOTE: Waypoint missions are stored on your phone, however the skill settings for that mission (speed between waypoints, lost comms behavior and photo at waypoint) are stored on the vehicle. If you run the same mission with different vehicles, make sure to set your Waypoint skill settings for each drone.

Flight

Cinematic Skills

Skydio 2/2+ offers unique camera views using autonomous flight and adjustable height and range settings to get the best shot.

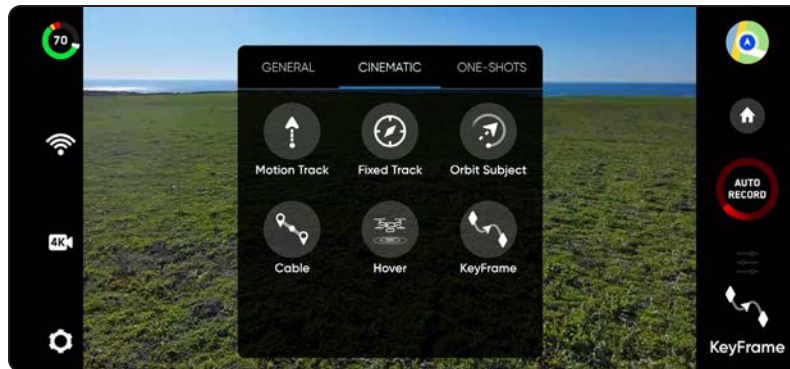

Motion Track

Skydio 2/2+ will track a subject from a specified angle relative to the subject's direction of motion, such as from the front, side or behind.



Fixed Track

Skydio 2/2+ will track a subject from a fixed angle regardless of which direction the subject is facing or moving.



Orbit Subject

Skydio 2/2+ will rotate around the selected subject in either a clockwise or counter-clockwise direction, keeping the subject in the center of the frame.



Cable

Mark two points in the sky and have Skydio 2/2+ fly along a fixed path between them. You can choose to track a subject while Skydio 2/2+ is on this fixed path.



Hover

Skydio 2/2+ will hover in a fixed position, as if affixed to a virtual tripod, rotating and tilting the camera to look at the subject as they move.





KeyFrame

Skydio 2/2+ will capture continuous shots along a user defined spline with complex, cinematic, and smooth camera motion.

Flight

Cinematic Skills

Subject Indicator - Select the  or  icon to lock onto the subject. Selecting the indicator will command the Skydio 2/2+ to enter autonomous flight mode with the selected object as the tracking subject.



Subject available for tracking



Subject actively tracked

Tips for Best Tracking Performance

- The Skydio 2/2+ can track a single person or vehicle at a time. Skydio 2/2+ does not track pets or other animals.
- The subject you wish to track must be visible in the camera view in order to become available for tracking.
- If the indicator is not appearing for the subject you wish to track, try moving the Skydio 2/2+ closer and ensure they are framed in the center of the camera view.

Flight

One-Shot Skills

One-Shots are special skills that perform a specific maneuver and then end, returning to the previously selected skill once the shot is complete.



Dronie

Skydio 2/2+ will fly up and outward, increasing in range, while continuing to track the subject.



Rocket

Skydio 2/2+ will fly straight up to capture a bird's eye overhead view of the subject.



Boomerang

Skydio 2/2+ rotates once around the subject, beginning close, flying outward, and finally returning close to the subject.



Vortex

Skydio 2/2+ will fly up and outward while rotating around the subject.

Flight

Land

To land your drone, stop subject tracking and manually fly the drone to a safe landing spot that is flat, clear of debris, avoiding people or animals. Press and hold the **LAND** button.



Skydio 2/2+ will descend to 10 ft (3 m) above the surface below it. When Skydio 2/2+ altitude falls below 10 ft (3 m) the lights will turn yellow and obstacle avoidance will be disabled for the remainder of the landing. An alert will display to notify you of the change in status.

While Skydio 2/2+ is landing you may nudge the drone forwards, backward, left, or right using the Controller or digital thumbsticks in the app.

You may also cancel any non-emergency landing by selecting the **Cancel** button before the landing completes.

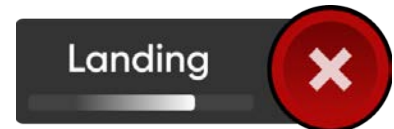

Cancel landing button



WARNING: Skydio may recognize bushes, trees and similar obstacles as potential surfaces. Make sure to first pilot your drone to an open area free of obstacles before initiating a landing.

Flight

Case Landing

It is not always possible to find a clean, level area to land your Skydio 2/2+. To initiate a case landing, the Skydio case must be in view of camera. A yellow ring will appear around the case in the live video feed to indicate that Skydio 2/2+ has identified the landing zone. If Skydio 2/2+ does not display the yellow ring, it will continue to descend straight down and land.



Piloting or nudging the drone during a case landing will cancel the case landing and continue with a normal landing.



NOTE: If a flight is initiated by taking off from a case (or a case is placed at Skydio 2/2+'s exact take off point), GPS positional accuracy cannot be relied upon to guarantee a case landing when using the Return to Home function (or in the case of an RTH triggered by lost communication).

Flight

Hand Landing



WARNING: Do not attempt hand-landing Skydio 2/2+ before the lights turn yellow. Attempting to hand-land Skydio 2/2+ while obstacle avoidance is active will cause it to attempt to avoid your hand and may result in Skydio 2/2+ impacting yourself or another nearby object. To avoid injury stay away from and do not touch rotating propellers when they are spinning. Skydio does not recommend launching the drone while holding the drone in your hand.

Step 1 - Ensure you have safe landing conditions

- low winds
- Skydio 2/2+ is hovering stationary within a few feet of you and is no longer following a subject
- Skydio 2/2+ is over clear ground so that you have ample space to move

Do not attempt a hand landing:

- during high winds
- if Skydio 2/2+ is not stable in flight for any reason
- if Skydio 2/2+ is performing an emergency landing after an accident or crash
- you are in an area where you do not have stable footing
- you are on a moving vehicle or boat

Step 2 - Rotate Skydio 2/2+ so that the camera is facing away from you

Step 3 - Initiate a landing through the app, Beacon or Controller as you would normally

- **Do not attempt Skydio 2/2+ hand landing without first initiating a landing. Doing so will result in the motors spinning at full speed and may cause severe injury.**
- Skydio 2/2+ will descend to 10 ft (3 m) above the surface below it. When Skydio 2/2+ is below 10 ft (3 m) level Skydio 2/2+ lights will turn yellow and obstacle avoidance will be disabled for the remainder of the landing. An alert will display to notify you of the change in status.
- **Do not attempt to hand-land Skydio 2/2+ before the lights turn yellow. Attempting to hand-land Skydio 2/2+ while obstacle avoidance is active will cause it to attempt to avoid your hand and may result in Skydio 2/2+ impacting yourself or another nearby object.**

Step 4 - Move yourself into a position that will allow the drone to safely land in your hand

- you will be able to nudge the drone forwards, backward, left, or right using the Controller or digital thumbsticks in the app
- the safest, and recommended, approach is to avoid nudging completely and adjust your position to meet the drone instead

While landing, Skydio 2/2+ is looking for a stable, motionless surface to ensure a safe touchdown:

- propellers will continue to spin for several seconds after touching down
- if Skydio 2/2+ is not level and motionless the motors may spin back up again. If this happens, maintain a firm grip on the battery to keep the drone flat and motionless.
- do not rotate or flip the drone during a hand landing, as the battery may dislodge

Post-flight

Viewing and Saving Media

After Skydio 2/2+ has landed, select the Review tab to view your media. Skydio will begin syncing any audio and video captured during your flight—Skydio 2/2+ must stay powered on and connected to the app while this sync is in progress for audio to be saved. To save media directly to your mobile device's photo album:

Step 1 - Select the **Review** menu

Step 2 - Select and hold a file to enter selection mode

Step 2 - Select all the media you wish to copy

Step 3 - Select **Save to Phone**

- Interval photo mode, all photos captured will appear as a single stack of photos. Selecting the stack will allow you to scroll through individual photos
- only the JPG files can be viewed in Skydio Enterprise app
- download the DNG image files directly from the SD card
- images contain EXIF data embedded to enable post flight analysis



NOTE: This method will not sync any recorded audio

You may also connect Skydio 2/2+ to your personal computer using the USB-C cable to view and copy your full-resolution video and photos directly off the microSD card. Ensure that your computer is connected to power to avoid draining the battery on Skydio 2/2+.

Step 4 - (optional) create a clip of the video to save instead of copying the entire video to your mobile device

- Skydio 2/2+ can record video in either AVC (H.264) or HEVC (H.265)
- different mobile devices and personal computers have different compatibilities with these encoding standards
- attempting to save a video or make a clip with an encoding that is not compatible with your mobile device may cause playback issues
- creating a clip will sync any recorded audio into the new file. Use this method when you want to save videos with audio



NOTE: Access your media by selecting the Media menu while your Skydio 2/2+ is connected to the Enterprise Controller or mobile device, but not when connected to Beacon.

Emergency Behaviors

Several of the emergency behaviors involve Skydio 2/2+ initiating an automatic return to home. The Return behaviors are set will be the same as a pilot-initiated return, and depending on your return settings, the drone will ascend before returning.

Lost Connection

In the event of a loss communication link or failure of the controlling device, Skydio 2/2+ will automatically return to the Home Point if one was specified or the original launch point, if no Home Point was specified. You will maintain the ability to customize Lost Connection return behaviors. View the launch point, home point and last known subject location on the map:

- select the **View Map** icon in the bottom right corner of the screen

If Skydio 2/2+ regains connection it will continue the current action, unless you cancel.



NOTE: if the drone is actively tracking a subject at the time of link loss, it will continue to follow the subject for 30 seconds while attempting to regain connection. If connection does not return after 30 seconds, Skydio 2/2+ will automatically return to the Home Point (if one was specified) or the last known location of the tracked subject (if no Home Point was specified).

Lost Connection Return Behaviors

Choose how you want your drone to behave if the signal to your controlling device is lost:

Step 1 - Select the Settings menu

Step 2 - Select the Drone tab

Step 3 - Select Return Behaviors

Step 4 - Select Lost Connection

- **Return when Disconnected** - toggle Off to disable Return when Disconnected and the Lost Connection menu. Skydio 2/2+ will not return if it loses connection—it will hover until it reaches low battery and land.
- **Wait Before Return** - set the amount of time that you want Skydio 2/2+ to wait before it initiates a return flight, allowing time to reconnect.
- **Land Once Returned** - when enabled, Skydio 2/2+ will return, hover for a specified amount of time, and land.
- **Wait Before Land** - set the amount of time between 0 to 300 seconds (the default is 240 seconds) that you want Skydio 2/2+ to wait before landing. This setting is only enabled when **Land Once Return** is toggled on.

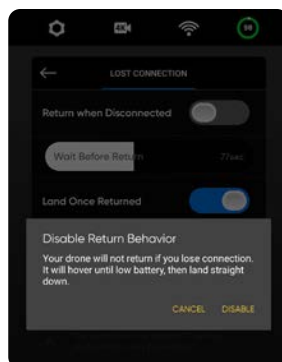
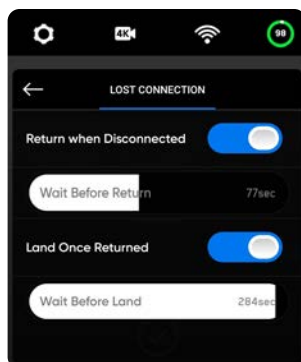

Emergency Behaviors

Lost GPS Signal

In the event that the Skydio 2/2+ GPS signal is lost, the drone will continue flying as normal. You will still be able to Return Home and fly to waypoint, however Skydio 2/2+ flight will be less accurate.

Skydio 2/2+ loses GPS during Waypoint Mission

If Skydio 2/2+ loses GPS while executing a Waypoint mission, the drone will continue on and attempt to fly to each waypoint. At the final waypoint a GPS Lost alert message will display. You may manually pilot the drone and attempt to regain a GPS signal, to restart the mission.

Skydio 2/2+ never had GPS

If Skydio 2/2+ never obtains a strong GPS signal (it's either poor or non-existent throughout the flight), you may not be able to set a Home Point, fly to a waypoint, or return to phone/Home. If your **Return Type** is set to **Vision**, however, you will be able to reliably return to the **Launch Point** using the vision navigation system.



NOTE: When Skydio 2/2+ is flying high up in the air or over large bodies of water, visual positioning becomes more difficult and the drone relies on GPS to assist with lateral positioning. In the event that GPS is lost in such conditions, Skydio 2/2+ lateral positioning will be affected and the drone may initiate an emergency landing.

Low Battery

When Skydio 2/2+ battery is low, there will be a series of notifications and actions to ensure a safe landing:

- Skydio 2/2+ will assess your altitude and distance from the Home Point, then warn you when it is time to return home. It is recommended to you initiate a return or land at this time, however you can choose to keep flying.
- Skydio 2/2+ will then notify you when it has 2 minutes of flight time left based on its current altitude and the battery indicator will begin a two-minute countdown. You may choose to continue flying, however it is strongly recommended that you fly to a safe location and land.
- When the two-minute countdown is complete, Skydio 2/2+ will initiate an automatic landing that you will be unable to cancel. You will maintain the ability to nudge the drone in roll, pitch, and yaw to avoid any obstacles.



NOTE: Skydio 2/2+ will **not** automatically return to the home point when it reaches low battery. It will simply notify you that it's time to return, at which point you will need to command a return using the Return to Home button in the app or on the Skydio 2/2+ Controller.

Emergency Behaviors

Recovering lost drone

In the event that your Skydio 2/2+ is lost, you may view its last known location:

Step 1 - Select **INFO** menu

Step 2 - Select your device name

Step 3 - Select **Find Drone**

- if the Coordinate setting is enabled, the latitude and longitude of the current or last known location will be displayed, making it easier for you to locate your lost drone.

View Last Flight

The View Last Flights feature is designed to assist you with locating your drone in the event of a crash, emergency landing, or low battery landing in an unintended location:

Step 1 - Select **INFO** menu

Step 2 - Select **Device Name**

Step 3 - Select **View Last Flights**

- review video of the 10 most recent flights

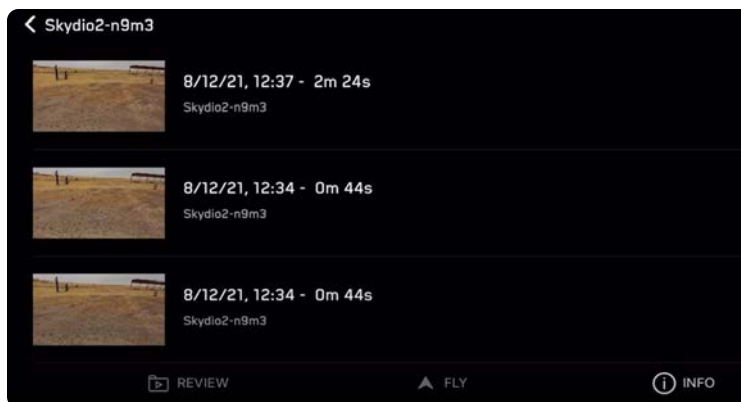
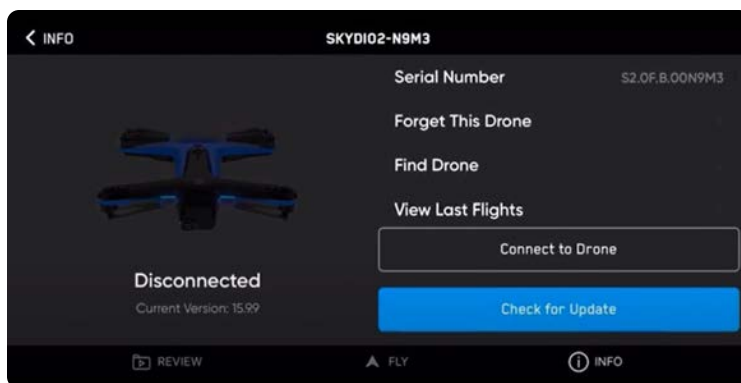

Maintenance

Battery safety guidelines

- Charge your Skydio 2/2+ batteries using only the Skydio supplied charging power adapter or dual charger accessory (dual charger sold separately). We recommend using the provided power adapter; however, most USB-C power adapters that are rated from 40W up to 100W should be compatible as well (charge time may be affected when using non-Skydio chargers).
- While charging, the Skydio 2/2+ or Dual Charger should be in an open area as it is normal for the device to become warm to the touch.
- TSA and FAA guidelines state that spare (uninstalled) lithium batteries must be transported in carry-on baggage only. When traveling with Skydio 2/2+ in the United States, be sure to pack your batteries in your carry-on luggage only. For more info, please see this FAA page. When traveling with Skydio 2/2+ outside of the United States, check local regulations before transporting batteries.
- Do not use your Skydio 2/2+ batteries at temperatures below 32°F (0°C), as they will not function properly below that temperature. If your batteries do get cold, warm them up in a room-temperature environment - DO NOT use higher heat (hairdryer, etc.) to accelerate heating.
- Do not charge your batteries when ambient temperature is above 95°F (35°C) or below 50°F (10°C). Batteries will not charge when too hot or too cold.
- If storing your batteries long-term, we recommend fully charging and discharging them every two months.
- Store your batteries at room temperature (71°F - 82°F / 22°C - 28°C) and away from any moisture (less than 75% relative humidity).
- Do not use any batteries which have become dented or begin to split apart (after a crash or drop).
- Do not immerse the batteries, charger, or charging docks in water or other liquids.
- Lithium polymer batteries can leak, overheat, melt, release harmful gas, burst or ignite when exposed to heat, water, and other liquids or when pierced, punctured or ruptured.
- If any substances from the battery pack get into your eyes, do not rub them. Seek medical attention immediately.
- Take care when disposing of the battery pack. Contact your local waste facility to verify if lithium polymer batteries are permitted in your regular waste. Many stores also offer free recycling.
- Never insert any other materials into the Skydio 2/2+ battery terminals.

Maintenance

Replace Propeller Blades

Before every flight, inspect your Skydio 2/2+ propellers to ensure they are in good condition. If damaged, or you have flown your drone more than 25 hours, Skydio recommends replacing your propellers.

Step 1 - Match propellers to hooks

- match props to the correct color hook (blue or gray)
- match the ring location (inner or outer) by flipping over the prop to locate

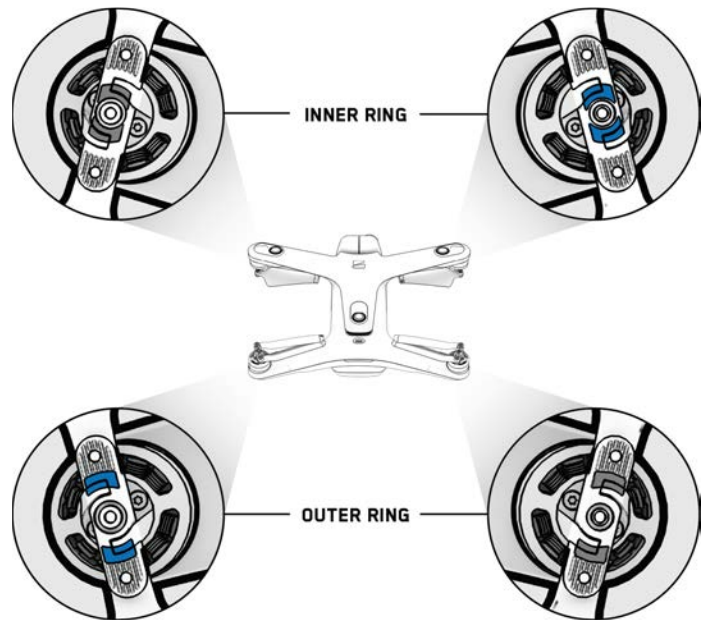

Step 2 - Remove old propellers

- hold the motor with one hand
- push down and twist to release old propeller blade assembly

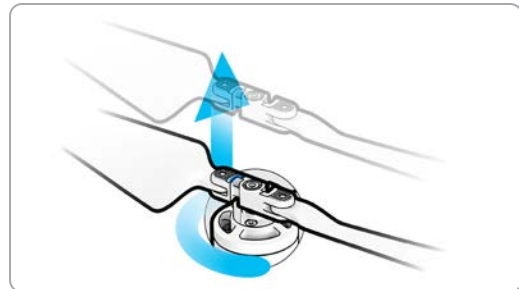

Step 3 - Install new propellers

- hold the motor with one hand
- push down and twist to install new props

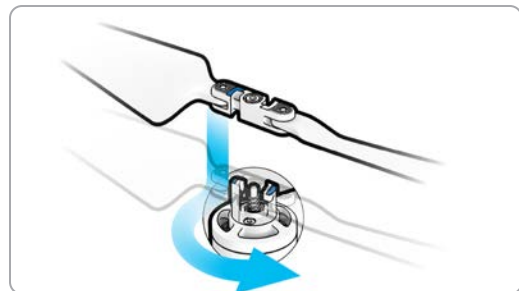

Maintenance

Updating Skydio 2/2+

Skydio is always improving and adding new features to Skydio 2/2+. These improvements are enabled with periodic software updates for the Skydio Enterprise app, Skydio 2/2+, and the Skydio Beacon and Controller.

Software updates for your drone and any Skydio accessories are delivered through the Skydio Enterprise app. When an update is available, you will receive a notification alert.

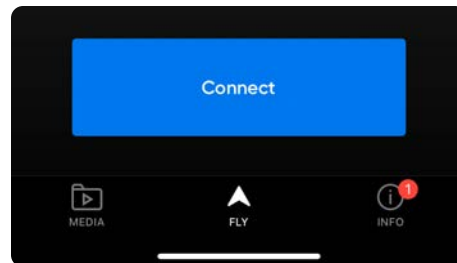

To install the update:

Step 1 - Select the **INFO** menu

Step 1 - Select **Devices**

Step 2 - Select your Skydio 2/2+

- follow the prompts to start the update
- the illustrations below are from an iOS device, but the process looks almost identical on an Android device

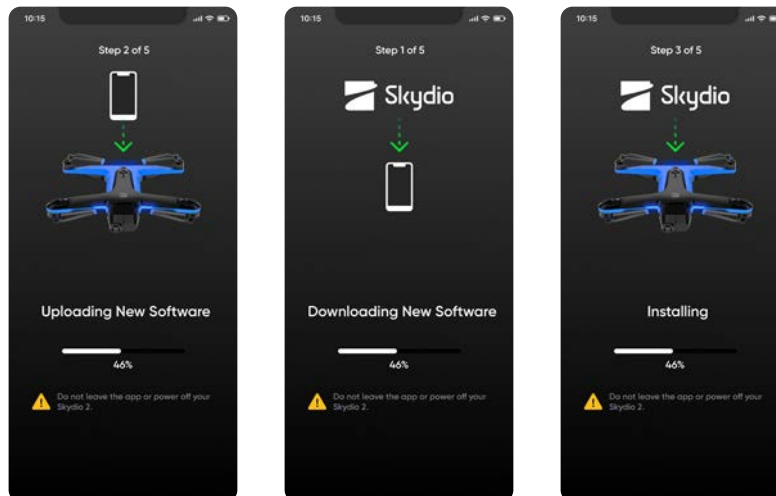

Skydio 2 Enterprise Specifications

SKYDIO 2 GENERAL	
SIZE WITH BATTERY	223 x 273 x 74 mm (l x w x h)
SIZE WITHOUT BATTERY	223 x 273 x 43 mm (l x w x h)
SIZE OF INCLUDED HARD CASE	297 x 255 x 65 mm (l x w x h) (case fits: drone, spare propellers, charging cable, and either 2 batteries or 1 battery and 1 wall adapter)
WEIGHT (WITH BATTERY)	775 g
FLIGHT TIME	23 minutes
MAX FLIGHT SPEED (SEA LEVEL, NO WIND)	36 mph (fully autonomous)
MAX WIND SPEED RESISTANCE	25 mph
MAX SERVICE CEILING (ABOVE SEA LEVEL)	15,000 ft density altitude
MAX FLIGHT ALTITUDE (FROM CONTROL DEVICE)	1,640 ft
OPERATIONAL TEMPERATURE RANGE	-5°C to 40°C

SKYDIO 2 AUTONOMY SYSTEM	
MAIN PROCESSOR	NVIDIA Tegra X2 SOC
GPU	256-core NVIDIA Pascal™ GPU
CPU	Dual-Core NVIDIA Denver 2 64-bit CPU Quad-Core ARM®-A57 MPCore
RAM	4GB 128-bit LPDDR4
OBSTACLE AVOIDANCE COVERAGE	Omnidirectional and above/below Super fisheye lenses for 360° view
3D WORLD MODEL UPDATE RATE	> 1 million points per second
WORLD MODEL-TO-ACTION UPDATE RATE	500 iterations per second
ON BOARD AI	9 custom deep networks used in flight
USER-SELECTABLE SUBJECTS FOR TRACKING	People and motor vehicles
OBJECT TRACKING AND IDENTIFICATION	Up to 10 simultaneous objects of interest
CALIBRATION	Automated online calibration of lens parameters, camera rotations, wind speed, and air density

Skydio 2 Enterprise Specifications

SKYDIO 2 WIRELESS & GPS	
RANGE TO PHONE (LINE OF SIGHT, IDEAL CONDITIONS)	200 m
RANGE TO BEACON (LINE OF SIGHT, IDEAL CONDITIONS*)	Up to 1.5 km
RANGE TO CONTROLLER (LINE OF SIGHT, IDEAL CONDITIONS*)	Up to 3.5 km
OPERATING FREQUENCIES	2.4-2.483 GHz 5.18-5.24 GHz 5.725-5.85 GHz
CHANNEL WIDTH (STANDARD WIFI)	20, 40, and 80 MHz
CHANNEL WIDTH (SKYDIO LINK™)	5 and 10 MHz
GPS SATELLITE CONSTELLATIONS	GPS and GLONASS

**maximum range may be achieved under ideal conditions, which vary depending on weather, temperature, electromagnetic or other interference, visual line of sight, obstacles and other factors.*

SKYDIO 2 NAVIGATION CAMERA SYSTEM	
CONFIGURATION	6x cameras in trinocular configuration top and bottom
SENSOR TYPE	Sony 1/3" 4K color CMOS
LENS APERTURE	f/1.8
FIELD-OF-VIEW	200°
ENVIRONMENT COVERAGE	True 360°
FRAME RATE	30 FPS

Skydio 2 Enterprise Specifications

SKYDIO 2 PRIMARY CAMERA SYSTEM	
SENSOR TYPE	Sony IMX577 1/2.3" 12.3MP CMOS
SENSOR ACTIVE PIXELS	4056 (H) x 3040 (V)
LENS APERTURE	f/2.8
LENS FOCAL LENGTH	20mm (35mm format equivalent)
LENS DEPTH OF FIELD	1m - ∞
SHUTTER SPEED	electronic shutter 1 to 1/1920s
ISO RANGE	video 100-3200 photo 100-3200
EXPOSURE CONTROL	-2.0, -1.5, -1.0, -0.5, 0, 0.5, 1.0, 1.5, 2.0
IMAGE SIGNAL PROCESSOR	Qualcomm QCS605
GPU	Adreno™ 615
CPU	64-bit octa-core Kryo™ 300
DSP	Hexagon™ 685, 2x HVX
RESOLUTION AND MODES	3840x2160 30 fps 3840x2160 60 fps 3840x2160 48 fps 3840x2160 24 fps 1920x1080 120 fps 1920x1080 60 fps 1920x1080 30 fps
BITRATE	100 Mbps
VIDEO FORMAT	MPEG-4 (AVC/H.264, HEVC/H.265)
STILL RESOLUTION	4056x3040 (12 MP)
STILL FORMATS	JPEG, DNG (RAW)
STILL MODES	Single, Interval
DYNAMIC RANGE	13 stops
STORAGE	Removable Micro SD Card UHS Speed Class 3 / V30
STABILIZATION MECHANICAL RANGE	pitch ±124°, roll ±120°, yaw ±12.5°
PITCH CONTROLLABLE RANGE	-110° to +45°

Skydio 2+ Enterprise Specifications

SKYDIO 2+ GENERAL	
SIZE WITH BATTERY	223 x 273 x 74 mm (l x w x h)
SIZE WITHOUT BATTERY	223 x 273 x 43 mm (l x w x h)
SIZE OF INCLUDED HARD CASE	297 x 255 x 65 mm (l x w x h) (case fits: drone, spare propellers, charging cable, and either 2 batteries or 1 battery and 1 wall adapter)
WEIGHT (WITH BATTERY)	775 g
FLIGHT TIME (WITH SKYDIO 2+ BATTERY)	27 minutes
FLIGHT TIME (WITH SKYDIO 2 BATTERY)	23 minutes
MAX FLIGHT SPEED (SEA LEVEL, NO WIND)	36 mph (fully autonomous)
MAX WIND SPEED RESISTANCE	25 mph
MAX SERVICE CEILING (ABOVE SEA LEVEL)	15,000 ft density altitude
MAX FLIGHT ALTITUDE (FROM CONTROL DEVICE)	1,640 ft
OPERATIONAL TEMPERATURE RANGE	-5°C to 40°C

SKYDIO 2+ AUTONOMY SYSTEM	
MAIN PROCESSOR	NVIDIA Tegra X2 SOC
GPU	256-core NVIDIA Pascal™ GPU
CPU	Dual-Core NVIDIA Denver 2 64-bit CPU Quad-Core ARM®-A57 MPCore
RAM	4GB 128-bit LPDDR4
OBSTACLE AVOIDANCE COVERAGE	Omnidirectional and above/below Super fisheye lenses for 360° view
3D WORLD MODEL UPDATE RATE	> 1 million points per second
WORLD MODEL-TO-ACTION UPDATE RATE	500 iterations per second
ON BOARD AI	9 custom deep networks used in flight
USER-SELECTABLE SUBJECTS FOR TRACKING	People and motor vehicles
OBJECT TRACKING AND IDENTIFICATION	Up to 10 simultaneous objects of interest
CALIBRATION	Automated online calibration of lens parameters, camera rotations, wind speed, and air density

Skydio 2+ Enterprise Specifications

SKYDIO 2+ WIRELESS & GPS	
RANGE TO PHONE (LINE OF SIGHT, IDEAL CONDITIONS)	200 m
RANGE TO BEACON (LINE OF SIGHT, IDEAL CONDITIONS*)	Up to 1.5 km
RANGE TO CONTROLLER (LINE OF SIGHT, IDEAL CONDITIONS*)	Up to 6 km
OPERATING FREQUENCIES	2.4-2.483 GHz 5.18-5.24 GHz 5.725-5.85 GHz
CHANNEL WIDTH (STANDARD WIFI)	20, 40, and 80 MHz
CHANNEL WIDTH (SKYDIO LINK™)	5 and 10 MHz
GPS SATELLITE CONSTELLATIONS	GPS and GLONASS

**maximum range may be achieved under ideal conditions, which vary depending on weather, temperature, electro-magnetic or other interference, visual line of sight, obstacles and other factors.*

SKYDIO 2+ NAVIGATION CAMERA SYSTEM	
CONFIGURATION	6x cameras in trinocular configuration top and bottom
SENSOR TYPE	Sony 1/3" 4K color CMOS
LENS APERTURE	f/1.8
FIELD-OF-VIEW	200°
ENVIRONMENT COVERAGE	True 360°
FRAME RATE	30 FPS

Skydio 2+ Enterprise Specifications

SKYDIO 2+ PRIMARY CAMERA SYSTEM	
SENSOR TYPE	Sony IMX577 1/2.3" 12.3MP CMOS
SENSOR ACTIVE PIXELS	4056 (H) x 3040 (V)
LENS APERTURE	f/2.8
LENS FOCAL LENGTH	20mm (35mm format equivalent)
LENS DEPTH OF FIELD	1m - ∞
SHUTTER SPEED	electronic shutter 1 to 1/1920s
ISO RANGE	video 100-3200 photo 100-3200
EXPOSURE CONTROL	-2.0, -1.5, -1.0, -0.5, 0, 0.5, 1.0, 1.5, 2.0
IMAGE SIGNAL PROCESSOR	Qualcomm QCS605
GPU	Adreno™ 615
CPU	64-bit octa-core Kryo™ 300
DSP	Hexagon™ 685, 2x HVX
RESOLUTION AND MODES	3840x2160 30 fps 3840x2160 60 fps 3840x2160 48 fps 3840x2160 24 fps 1920x1080 120 fps 1920x1080 60 fps 1920x1080 30 fps
BITRATE	100 Mbps
VIDEO FORMAT	MPEG-4 (AVC/H.264, HEVC/H.265)
STILL RESOLUTION	4056x3040 (12 MP)
STILL FORMATS	JPEG, DNG (RAW)
STILL MODES	Single, Interval
DYNAMIC RANGE	13 stops
STORAGE	Removable Micro SD Card UHS Speed Class 3 / V30
STABILIZATION MECHANICAL RANGE	pitch ±124°, roll ±120°, yaw ±12.5°
PITCH CONTROLLABLE RANGE	-110° to +45°

Legal

Compliance Information

FCC

Any changes or modifications to this equipment not expressly approved by Skydio for compliance will void the user's authorization to operate this equipment.

This equipment has been tested and found to comply with the limits for a Class B digital device, pursuant to part 15 of the FCC Rules. These limits are designed to provide reasonable protection against harmful interference in a residential installation. This equipment generates, uses and can radiate radio frequency energy and, if not installed and used in accordance with the instructions, may cause harmful interference to radio communications. However, there is no guarantee that interference will not occur in a particular installation. If this equipment does cause harmful interference to radio or television reception, which can be determined by turning the equipment off and on, the user is encouraged to try to correct the interference by one or more of the following measures:

Reorient or relocate the receiving antenna

Increase the separation between the equipment and receiver

Connect the equipment into an outlet on a circuit different from that to which the receiver is connected

Consult the dealer or experienced radio/TV technician for help

This device complies with part 15 of the FCC Rules. Operation is subject to the following two conditions: (1) This device may not cause harmful interference, and (2) this device must accept any interference received, including interference that may cause undesired operation.

This equipment complies with FCC radiation exposure limits set forth for an uncontrolled environment. The distance between user and products should be no less than 20cm. The end user must follow the specific operating instruction for satisfying RF exposure compliance. This transmitter must not be co-located or operating in conjunction with any other antenna or transmitter

California Prop 65 Warning

Lithium-ion Batteries and/or products that contain Lithium-ion Batteries can expose you to chemicals including cobalt lithium nickel oxide, and nickel, which are known to the State of California to cause cancer and birth defects or other reproductive harm. For more information, visit www.P65Warnings.ca.gov

IC

This device contains licence-exempt transmitter(s)/receiver(s) that comply with Innovation, Science and Economic Development Canada's licence-exempt RSS(s). Operation is subject to the following two conditions:

This device may not cause interference

This device must accept any interference, including interference that may cause

L'émetteur/récepteur exempt de licence contenu dans le présent appareil est conforme aux CNR d'Innovation, Sciences et Développement économique Canada applicables aux appareils radio exempts de licence.

L'exploitation est autorisée aux deux conditions suivantes:

L'appareil ne doit pas produire de brouillage

L'appareil doit accepter tout brouillage radioélectrique subi, même si le brouillage est susceptible d'en compromettre le fonctionnement

