

Skydio Dock for X10: Operational readiness overview

Choosing the right site is one of the most important steps in getting your DFR program off the ground.

In this document, system requirements for the Dock for X10 Flight System are provided to guide the selection of safe and operationally viable installation locations. These system requirements are critical to reliable system performance.

Timely achievement of system requirements generally expedites system installation, initialization and operational use of the flight system.

For any questions related to custom installation configurations that may impede the achievement of any system requirements listed below, please contact the **Skydio DFR Launch Team** at XXXX@skydio.com.

Role of Skydio's DFR Launch Team

Skydio's DFR Launch Team is composed of project managers, network specialists, and deployment engineers. The team serves as a dedicated project partner to ensure that all system requirements are achieved prior to installation, and that all programmatic requirements of an agency's DFR program are met as flight system installation activities are conducted.

Skydio-authorized and certified personnel will survey installation sites, conduct installations of hardware and networking, and provide field services and system maintenance once the flight system is operational.

Skydio's DFR Launch Team may be contacted via Skydio Account Executives or Solutions Engineers. It is recommended to engage with the Launch Team as early in a project as possible.

Services provided:

- Installation site surveys
- Project management for flight system installation and initial deployment
- Communications with organizational stakeholders (Facilities, IT, Networking, etc.)

The Skydio Dock for X10 Flight System is the foundation of Skydio's Drone as First Responder (DFR) solution.

Each full Flight System consists of:

- (1) Skydio X10 Drone
- (1) Skydio Dock for X10
- (1) Skydio Connect External Radio
- (1) Skydio Cloud Organization* for the agency, which integrates with CAD, DEMS, and other tools used to maintain DFR operations

*All physical hardware purchased by an agency should be operated under the same Skydio Cloud organization for optimal operations and support



NOTE: Specifications, component details, and system configurations presented here reflect the latest version of the product at the time of publication which is subject to change. Refer to the official documentation and support resources for the most up-to-date guidance. It is the responsibility of the installer to ensure compliance with all applicable regulations, site requirements, and manufacturer instructions. Consult with the product team for clarification if any installation conditions fall outside standard use cases.

WARNING: The information in this resource is provided for reference only and is subject to change without notice based on ongoing updates to the X10 and Dock systems and its associated hardware, software, and installation protocols. Follow all official safety guidelines (as published in the Skydio Dock for X10 Operator Manual) and installation procedures when handling or deploying the Dock as improper installation may result in serious bodily harm and/or damage.

Power requirements

Circuit

15 A dedicated

Voltage

110–220 V AC (50–60 Hz)
Use 220 V for freezing sites

Power Draw

Up to 2200 W peak

Disconnect

Local switch accessible to Skydio and site personnel

Conduit

1" run to the right side of the Dock with a 4 ft tail for the junction box

Tip: End conduit ~6.5" above ground to protect cabling

Power load

2200W for operations below 32°F / 0°C

20A breaker for 208-220 V

1200 W for operations above 32°F / 0°C

15A breaker for 110 V

Why it matters:

Dedicated and appropriately sized power ensures stable charging, safe heating, and maximum uptime during cold-weather operations.

Network requirements

Each Dock requires a reliable data connection for communication and video backhaul.

Connection

Outdoor Cat6/6A shielded cable to both the Dock and the external radio

Firewall

Complete Skydio Cloud connectivity test before installation

Recommended bandwidth (single Dock):

Minimum 20 Mbps upload/ 20 Mbps download per Dock

Preferred 100 Mbps upload/ 100 Mbps download for smooth video streaming and software updates

Upload priority

Upload bandwidth is the critical factor for streaming video to Skydio Cloud

Latency

<100 ms

External radio

Mount ~5 ft above nearby obstructions with a clear line of sight in all directions

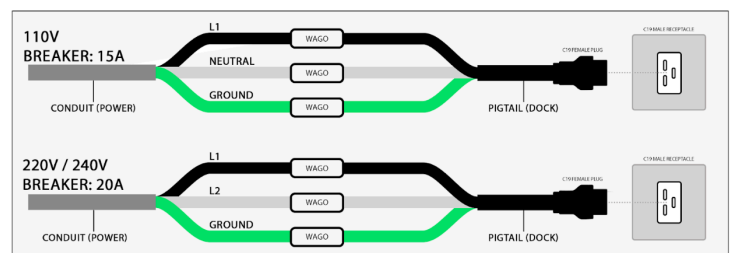
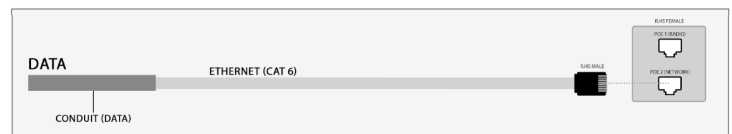
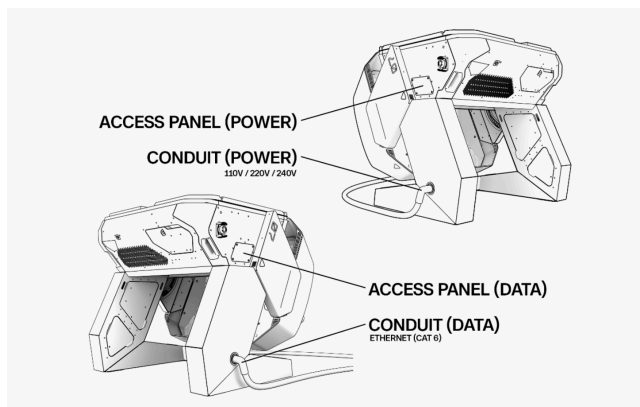

Space and placement

Clearance

Maintain a 12 ft clear radius around each Dock; minimum 5 ft between Docks

Sky visibility

Ensure a clear line of sight within a 40° elevation angle from the platform

Secure mounting

May be freestanding or bolted to a permanent structure

Bolting is recommended for hurricane or tornado-prone areas

Skydio offers large Dock feet that will secure the Dock in up to 80mph winds

Surface leveling

Landing surface must be within $\pm 3^\circ$ of level

Grounding is recommended for the external radio mast to the existing lightning protection hardware

Example:

A typical rooftop setup groups 3–4 Docks in a line with at least 12 ft clearance all around and external radios mounted ~17 ft away, elevated above nearby structures for a clear signal.

Why it matters:

Open, level, and unobstructed placement ensures safe, repeatable launches and landings in all conditions.

Environmental considerations

Operating

-4°F to 122°F
(-20°C to 50°C)

Standby

-40°F to 140°F
(-40°C to 60°C)

Weather protection

IPX6 (roof closed)
IPX5 (roof open)

Cold weather power

Use 220 V power for any site that experiences temperatures below 32°F

Dock for X10 wind tolerance

X10 Drone can launch in winds up to 27 mph; secured standby up to 100 mph

Bolted to Permanent Structure:
Up to 160 mph (257 kph)

Bolted with Skydio Dock Feet (Available late 2025):
80 mph (128 kph)

Non-Bolted: 40 mph (64 kph)

Why it matters:

Proper power and site preparation keep the Dock operational through extreme weather by keeping critical systems above freezing and the battery within charging temperatures.

Common site readiness items (avoid delays)

Roof access

Arrange keys, escorts, and safe working hours before installation

Crane or lift

Schedule with Facilities 2-3 weeks before install

Facilities/IT approvals

Identify and loop in all approvers early to avoid last-minute surprises

Firewall configuration

Complete network testing with Skydio before Docks ship

Cold-weather sites

Specify 220 V in procurement for reliable winter operations

Why it matters:

Early coordination prevents scheduling delays, repeat site visits, and time for both your team and the Skydio Launch team.

Questions?

Your Skydio representative will review every site detail and share diagrams during the pre-survey phase— this overview just helps you get started.

Once your readiness checklist is green, your DFR Launch Team will schedule installation, commission the system, and get you flying. Together, we'll make sure you're responding to calls faster—with zero wasted time, effort, or resources.