

Skydio Networking Guide - Dock for X10 Flight System

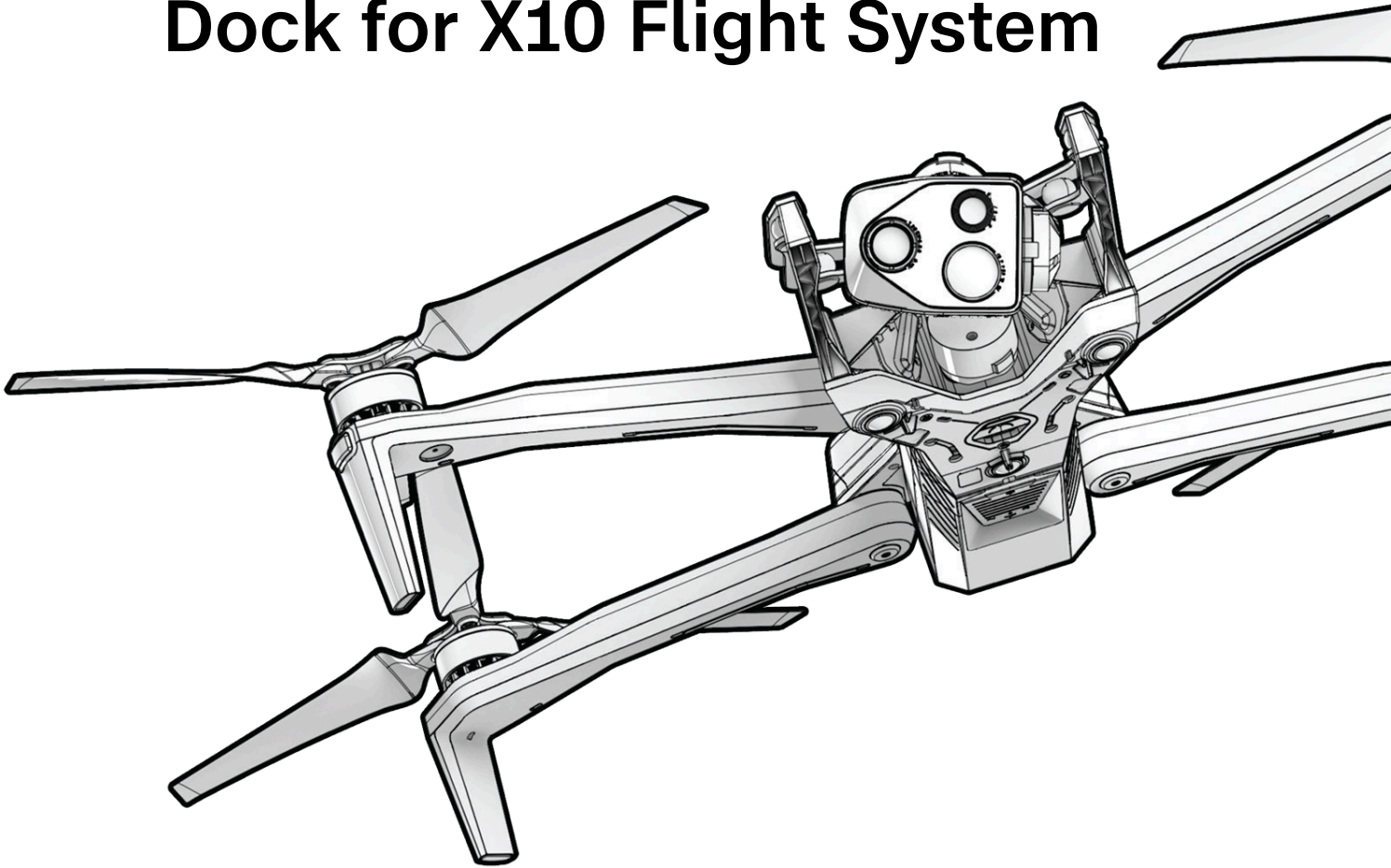

Skydio Networking Guide - Skydio X10 Flight System.....	3
Cable Installation.....	4
Data Requirements.....	5
Remote Flight Deck (RFD) Latency Requirements.....	6
General Networking Requirements.....	7
Firewall Requirements for Flight Systems and Remote Flight Deck (RFD).....	8
Revision History.....	14

Skydio Networking Guide - Skydio X10 Flight System

This document outlines the networking planning and configuration requirements, including port mapping and protocols, security, and connectivity for single and multiple Skydio Dock for X10 Flight System locations.

The X10 Drone is remotely piloted by operators logged into Remote Flight Deck (RFD). Using high-quality video feeds from the flight system, the pilot can launch, navigate to the mission site, monitor events, and return to the Dock. During flight, the X10 drone sends high-quality video over cellular and Skydio Link (SL). SL runs in the unlicensed 2.4 and 5 GHz spectrum that is also used by WiFi networks. To ensure an optimal flight experience, the system requires high throughput and low latency.

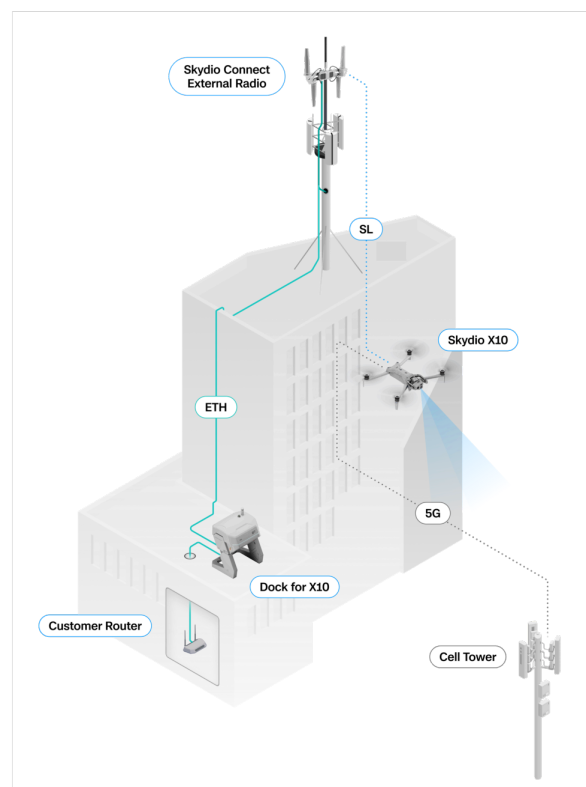

Cable Installation

This section contains information about cable installations.

Preparation

Before the Flight System can be installed, the customer must have the following infrastructure in place:

- Ethernet cables
- Outdoor surge protection
- Power and ground
- Configured Firewall or open network for necessary ports/sites

External Radio RJ45 Requirement



Note:

The Dock for X10 Installation Manual includes all required physical preparation.

The External Radio uses a weather-resistant connector designed to fit over most RJ45 cable connectors. If the RJ45 connector does not fit through the weather-proof seal, the cable will need to be terminated with a compatible RJ45 connector.

RJ45 cable connector requirements:

- No boot or jacket on the locking tab
- Minimal strain relief to avoid blocking the adapter
- Cable outer dimensions must be **5.3 mm to 6.5 mm**.

Outdoor Surge Protection

Outdoor Surge Protection is optional.

The External Radio and Dock for X10 have no unique outdoor surge protection requirements. The need for outdoor surge protection will vary based on local weather conditions and risk profiles. Follow established best practices for surge protection. Any standard surge protector that allows gigabit throughput and supports **802.3af** power will work with the Dock for X10 and External Radio.

Data Requirements

This section contains information about data requirements.

The X10 Flight System assumes the following bandwidth and data speed prerequisites are designed to ensure smooth flights, video, and data transfers for various numbers of flight systems.

Recommended data speeds for multiple Dock for X10 deployments at a single location:

Dock for X10 Count	Upload Mbps (Required)	Download Mbps (Required)
1	20 (10)	80 (20)
3	100 (20)	100
6	300 (40)	300

Recommended data speeds for pilot work stations on the same network:

Active Pilots	Upload Mbps (Required)	Download Mbps (Required)
1	7 (5)	30 (20)
3	21 (15)	90 (60)
5	35 (25)	150 (100)

All traffic from the flight systems will pass through the Skydio Cloud before reaching pilots. If there will be pilots on the same network as the Flight Systems, throughput requirements will need to be added together.

Remote Flight Deck (RFD) Latency Requirements

This section contains information about latency thresholds for supporting different levels of Remote Flight Deck performance, ranging from basic to optimal experiences

All components of the flight system and Remote Flight Deck (RFD) should support these latencies. Skydio recommends testing latency via <https://cloud.skydio.com/>.

Latency

Performance in Remote Flight Deck	Latency
Basic	< 100 ms
Good	< 50 ms
Optimal	< 20 ms

General Networking Requirements

This section contains information about general networking requirements.

All traffic from the Flight System travels through the Skydio Cloud before reaching pilots in Remote Flight Deck (RFD). The X10 Flight System can be completely separated from corporate or secure networks. All components of the Flight System require DHCP, DNS, and NTP.

- **DHCP:** The Flight System does not support static IP assignment. DHCP reservations may be configured on the server if static addresses are preferred.
- **DNS and NTP:** Public DNS and Skydio-provided NTP endpoints are used by default:
 - DNS to `8.8.8.8`
 - NTP to `time.skydio.com`

If customers choose to provide local DNS or NTP services, these must be supplied through DHCP. Skydio systems do not support manual configuration of DNS or NTP on the Dock or External Radio.

- **Traffic Inspection:** Not supported. Skydio traffic is encrypted end to end to ensure data privacy and security. To maintain low latency and optimal performance, Skydio traffic must not be intercepted, decrypted, or inspected.
- **Certificates:** Man-in-the-middle (MITM) interception that replaces Skydio certificates is not supported. Drones connect only through secure, trusted Skydio certificates.
- **MTU size:** The Skydio-required MTU size is **1500 bytes**. Smaller MTUs (common with some VPNs and older circuits) can cause the flight system to become inoperable. If the network cannot be configured to meet these requirements, contact Skydio for guidance.
- **MAC Address Filtering:** If enabled, allowlist the Dock and External Radio MAC addresses before Deployment Engineering arrives. These addresses can be viewed in Skydio Cloud or provided in advance.
- **Flow Control:** Enable flow control (also called “pause frames” on some hardware) on all customer routers and switches connected to Skydio systems. This prevents dropped packets and ensures stable video performance, especially when the customer WAN link is slower than the Dock uplink.

Firewall Requirements for Flight Systems and Remote Flight Deck (RFD)

This section contains information about firewall requirements for Flight Systems and RFD.

Skydio Remote Ops uses several domains and ports for real-time visibility and live streaming. Please ensure the following domains and ports are allowed by your firewall.

Skydio recommends using DNS names for firewall rules where possible. Any listed IP addresses will remain consistent.

Rule ID	IP Address	Protocol/Port	Destination	Description
			DNS Name	
1	44.237.178.82 52.39.114.182 35.84.246.249 52.89.241.109 35.84.174.167	TCP 443	*.skydio.com	<p>Client Workstations to Skydio Cloud</p> <p>The Client workstation that will be logging into Skydio Cloud will need access to the Skydio Cloud, API, and WebRTC components in order to manage, launch, and view missions.</p> <p>*From Workstations segments, Unrestricted outbound internet to endpoint.</p>
2	52.89.241.109 35.84.174.167	TCP 322	N/A	<p>Client Workstation to Livestreaming Services</p> <p>The Client Workstation needs access to WebRTC components in order to launch missions, conduct manual flights via Remote Flight Deck, and send live video streams.</p>
15	34.208.18.168	TCP/UDP 443	N/A	<p>The Client Workstation needs access to WebRTC components in order to launch missions, conduct manual flights via Remote Flight Deck, and send live video streams.</p>
3	50.112.181.82	TCP 7881	N/A	
4	34.214.163.204 54.190.113.196 35.155.8.20 52.40.22.162	UDP 50000-60000	N/A	
5	44.237.178.82 52.39.114.182 35.84.246.249	TCP (HTTPS) 443	*.skydio.com	
				<p>Dock to Skydio Cloud</p> <p>The Dock needs access to Skydio Cloud.</p>

Rule ID	IP Address	Protocol/Port	Destination	Description
			DNS Name	
	52.89.241.109 35.84.174.167			
6	44.237.178.82 52.39.114.182 35.84.246.249	TCP 51334		
7	35.166.132.69 34.214.68.80 100.20.220.165 35.85.110.98 35.164.30.49 52.32.44.190	UDP/QUIC 443	N/A	<p>Dock to Livestreaming Services</p> <p>The Dock needs access to WebRTC/QUIC components in order to launch missions, conduct manual flights via Remote Flight Deck, and send live video streams.</p>
9	34.208.18.168 50.112.181.82 34.214.163.204 54.190.113.196 35.155.8.20 52.40.22.162	TCP/UDP 40000-41000		
11	N/A	TCP 443	skydio-vehicle-data.s3-accelerate.amazonaws.com skydio-vehicle-data.s3.amazonaws.com skydio-vehicle-data.s3-us-west-2.amazonaws.com skydio-vehicle-data.s3-fips.us-west-2.amazonaws.com skydio-vehicle-data.s3-fips.dualstack.us-west-2.amazonaws.com	<p>Dock to S3</p> <p>The Dock needs access to specific AWS S3 bucket endpoints over HTTPS. This includes both regular and S3 Accelerate endpoints. These S3 buckets are for downloading software updates and uploading media.</p>

Rule ID	IP Address	Protocol/Port	Destination	Description
			DNS Name	
			skydio-flight-data.s3-accelerate.amazonaws.com	
			skydio-flight-data.s3.amazonaws.com	
			skydio-flight-data.s3-us-west-2.amazonaws.com	
			skydio-flight-data.s3-fips.us-west-2.amazonaws.com	
			skydio-flight-data.s3-fips.dualstack.us-west-2.amazonaws.com	
			skydio-organization-files.s3-accelerate.amazonaws.com	
			skydio-organization-files.s3.amazonaws.com	
			skydio-organization-files.s3-us-west-2.amazonaws.com	
			skydio-organization-files.s3-fips.us-west-2.amazonaws.com	
			skydio-organization-files.s3-fips.dualstack.us-west-2.amazonaws.com	
			skydio-ota-diff-updates.s3-accelerate.amazonaws.com	
			skydio-ota-diff-updates.s3.amazonaws.com	
			skydio-ota-diff-updates.s3-us-west-2.amazonaws.com	
			skydio-ota-diff-updates.s3-fips.us-west-2.amazonaws.com	

Rule ID	IP Address	Protocol/Port	Destination	Description
			DNS Name	
			skydio-ota-diff-updates.s3-fips.dualstack.us-west-2.amazonaws.com	
			skydio-ota-updates.s3-accelerate.amazonaws.com	
			skydio-ota-updates.s3.amazonaws.com	
			skydio-ota-updates.s3-us-west-2.amazonaws.com	
			skydio-ota-updates.s3-fips.us-west-2.amazonaws.com	
			skydio-ota-updates.s3-fips.dualstack.us-west-2.amazonaws.com	
			skydio-controller-ota-updates.s3-accelerate.amazonaws.com	
			skydio-controller-ota-updates.s3.amazonaws.com	
			skydio-controller-ota-updates.s3-us-west-2.amazonaws.com	
			skydio-controller-ota-updates.s3-fips.us-west-2.amazonaws.com	
			skydio-controller-ota-updates.s3-fips.dualstack.us-west-2.amazonaws.com	
			skydio-media-thumbnails.s3-accelerate.amazonaws.com	
			skydio-media-thumbnails.s3.amazonaws.com	
			skydio-media-thumbnails.s3-us-west-2.amazonaws.com	

Rule ID	IP Address	Protocol/Port	Destination	Description
			DNS Name	
			skydio-media-thumbnails.s3-fips.us-west-2.amazonaws.com skydio-media-thumbnails.s3-fips.dualstack.us-west-2.amazonaws.com skydio-media-sync-test-files.s3-accelerate.amazonaws.com skydio-media-sync-test-files.s3.amazonaws.com skydio-media-sync-test-files.s3-us-west-2.amazonaws.com skydio-media-sync-test-files.s3-fips.us-west-2.amazonaws.com skydio-media-sync-test-files.s3-fips.dualstack.us-west-2.amazonaws.com	
12	N/A	TCP 443	online-level.services.ublox.com offline-level.services.ublox.com	Dock to Ublox AssistNow The Vehicle accesses an online service to download additional data to improve time to acquire a GPS fix.
13	8.8.8.8	UDP 53	N/A	DNS If the network does not provide DNS over DHCP, then this firewall rule is required.
14	35.162.55.206 44.237.178.82 52.39.114.182 35.84.246.249	UDP 123	time.skydio.com	NTP The Dock and Vehicle use either DHCP provided NTP or the <code>time.skydio.com</code> NTP server to set the system clock to the correct time.

Rule ID	IP Address	Protocol/Port	Destination	Description
			DNS Name	
				If using a self-hosted NTP server that is not configured by DHCP, contact Skydio Support.

Revision History

This section contains revision history information.

Revision	Description	Date
1	Initial Release (Archived)	November 14, 2025
2	Updated the following: <ul style="list-style-type: none">• Removed non-technical information.• Updated layout and Firewall settings.	January 8, 2026
3	Updated Rule 12 and Rule 15 port IDs..	January 14, 2026