

Skydio Dock for X10 Maintenance Manual

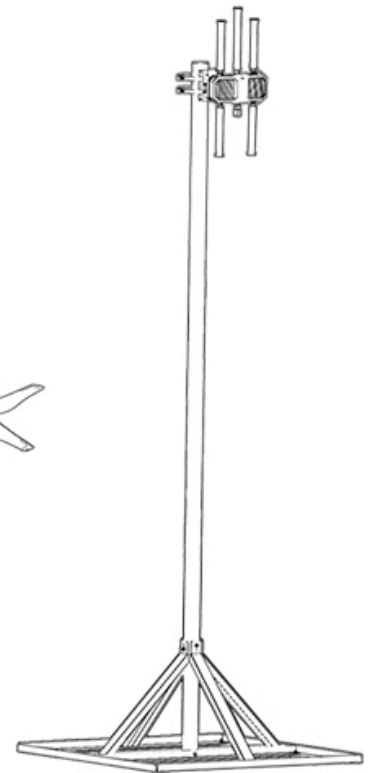
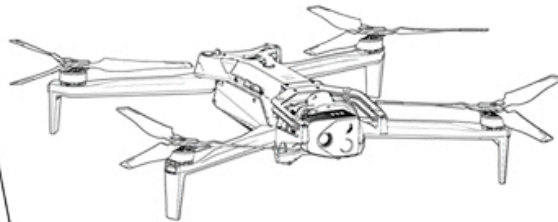
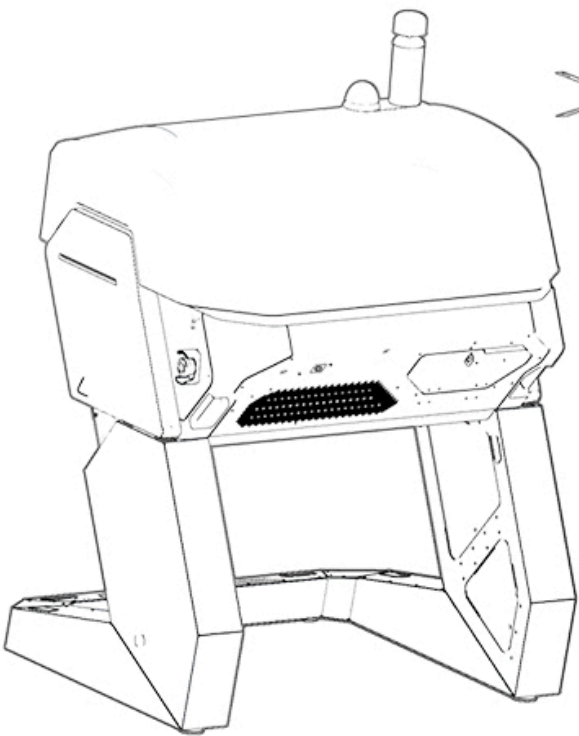

Maintenance Manual	3
How to Use This Manual.....	3
Dock for X10 Service Life.....	3
Safety Guidelines.....	4
Inspection and Maintenance Intervals.....	7
Customer-Provided Maintenance.....	7
Skydio-Provided Maintenance.....	10
General Care.....	12
Overview.....	12
Preflight Inspection.....	12
Functional Check Flights.....	12
Diagnostics and Troubleshooting.....	12
Flight System Health.....	13
Device Pages.....	15
How to Clean the Dock for X10 Flight System.....	28
Monitoring and Routine Maintenance.....	37
Replacing a Drone and Returning to Operations.....	38
How to Replace a Sensor Package.....	42
Customer Maintenance Actions.....	51
Functional Check Flights.....	78
Emergency Stop and Lockout/Tagout.....	84
Maintenance Logs.....	86
Skydio Support.....	87
How-To: Contact Skydio Support.....	87
How-To: Uploading Support Logs.....	88
Terms and Conditions.....	90
Revision History.....	93

Maintenance Manual

This document explains routine care, inspections, basic diagnostics and troubleshooting, when to contact Skydio Support, annual maintenance expectations, and how to log maintenance for compliance for the Skydio Dock for X10 Flight System, External Radio, and Drone.

How to Use This Manual

Important:

Skydio reserves the right to modify, update, or discontinue maintenance terms at its sole discretion. Please refer to the latest version of this manual for the most current information.

To optimize the performance of the Skydio Dock for X10 Flight System, it is important to keep the system updated, inspect equipment, clean equipment properly, and replace propellers and batteries as-needed.

In the United States, under guidance from the Federal Aviation Administration (FAA), remote pilots are responsible for maintaining the flight system in accordance with manufacturer's guidelines and logging all maintenance intervals. A Maintenance Log has been provided in this manual, along with all Maintenance Intervals and protocols required to ensure safe operation over the lifespan of the flight system.

Dock for X10 Service Life

Skydio Dock for X10 has a service life of 5 years with recommended maintenance.

NOTICE

Follow official documentation and updates.

Failure to follow any instructions or recommendations in Skydio documentation may void the Skydio Limited Warranty or other terms and conditions.

Please read all documentation provided with the Skydio Dock for X10, including but not limited to the Doc for X10 Safety Guidelines in the Safety and Operating Guide: www.skydio.com/safety.

Safety Guidelines

This section contains safety and functionally critical information.

DANGER:

Electrical hazard. Exposure to energized components can result in serious injury or death. Follow local/site specific lockout/tagout procedures for de-energizing the Dock and removing electrical hazards. Ensure the work area is clear of unnecessary personnel. If necessary, restrict access to the area.

Before performing service on the unit, do the following:

- Engage the Dock E-Stop button.
- Turn the Dock OFF.
- Disconnect the Dock from the AC power supply.
- Disconnect all external data and power cables from the Dock.
- Complete required lockout/tagout procedures per site requirements.

DANGER:

Motorized Dock for X10 moving parts. Moving parts may close or move unexpectedly. Pinch points will cause serious injury or death. Ensure the work area is clear of unnecessary personnel. Maintain a 7.0 ft (2.1 m) distance from all moving mechanisms. Obey all labels and warnings on the Dock. Follow local/site specific lockout/tagout procedures for de-energizing the Dock.

DANGER:

Risk of fire, explosion, serious injury, or death. Failure to follow battery safety warnings and handling guidelines can cause fire, explosion, or severe burns, resulting in serious injury or death, and may damage the drone, Dock, or surrounding property. Incorrect battery replacement can cause fire or explosion, resulting in serious injury, death, or property damage.

WARNING:

Risk of serious bodily injury or property damage due to improper maintenance. Failure to maintain the Skydio Dock for X10 Flight System may result in system performance failures. Annual maintenance and servicing internal components must be performed by Skydio-authorized technicians or Field Services teams. Failure to adhere to this guidance may increase the risk of serious bodily injury and/or property damage.

WARNING:

Risk of serious injury or loss of control from propellers. Keep all limbs and body parts away from the Skydio X10 drone while it is in motion or in flight. Contact with moving propellers can cause severe injury or death. Never fly with damaged propellers. If cracks, nicks, bends, or other visible damage are found, do not proceed with flight. Skydio recommends replacing all four propellers at once prior to the next flight.

WARNING:

Reduced flight safety. Exceeding recommended propeller flight hours can result in propeller failure, equipment damage, or loss of aircraft control. Track propeller flight hours. Regularly inspect propellers. Replace propellers within specified service limits.

WARNING:

Risk of fire or equipment damage. Use only batteries designed specifically for use with Skydio equipment. Do not install or operate the system with incompatible cells or batteries.

WARNING:

Risk of fire, explosion, or injury from extreme environmental conditions. Exposure to extreme heat or cold can cause cell rupture, thermal runaway, or fire resulting in serious injury or property damage.

Do not charge, use, or store batteries in the following conditions:

- Extreme temperatures (below 14°F / -10°C or above 140°F / 60°C)
- Direct sunlight
- Inside hot vehicles

WARNING:

Risk of fire, explosion, or injury from damaged or improperly handled batteries. If a battery shows signs of damage, such as substantial gouging or cracking of the plastic housing, place it in a non-flammable enclosure away from people and contact a local hazardous waste recycling agency for safe handling and disposal. Do not dismantle, open, or shred batteries. Do not dispose of batteries in regular garbage or recycling bins. Lithium polymer batteries must be disposed of only at certified electronic waste or battery recycling facilities. Never include batteries in burned waste. Lithium polymer batteries contain flammable materials that can cause explosive fires when overheated and may re-ignite due to thermal runaway. Do not store batteries in metal containers without appropriate insulation. Store damaged and undamaged batteries separately in temperature-controlled, non-conductive containers.

WARNING:

Risk of fire, explosion, or injury during shipment of lithium-ion batteries. Unless requested by Skydio as part of a Return Material Authorization (RMA) process, do NOT return batteries to Skydio. If requested to return batteries to Skydio, follow the instructions provided by Skydio customer support for safe handling and transport. Do not ship damaged or leaking batteries. Ship batteries only in compliance with all applicable IATA, DOT, and local transport regulations. Discharge batteries to 30–50% state of charge before shipment.

Do the following:

- Cover terminals
- Package each battery separately in non-conductive material
- Label packages as “Lithium-ion Batteries, UN3480/UN3481.”

CAUTION:

Risk of damage to Anemometer or Rain Sensor during roof operation. Potential damage to the Anemometer or Rain Sensor. When manually opening or closing the roof of the Dock, do not grab the Roof by the Anemometer or Rain sensor.

CAUTION:

Risk of equipment misconfiguration or operational failure. Do not attempt to pair a Dock-assigned drone with a Skydio X10 Controller, as this configuration is not supported. If pairing is absolutely necessary, extensive reconfiguration is required and must be coordinated through Skydio Support.

CAUTION:

Risk of equipment damage. Improper handling during Sensor Package replacement may damage the housing, the drone frame, or electrical connection points. To remove or install, lift or lower the Sensor Package up/down vertically. Do not pull the Sensor Package off at an angle. Do not use a peeling motion when removing the Sensor Package.

CAUTION:

Risk of Battery damage from improper storage conditions or low state of charge. Do not store Batteries at a very low state of charge (< 30%). Before long-term storage to prevent irreversible cell damage, charge Batteries to approximately 50%. Keep unused batteries in a cool, dry area with less than 75% relative humidity. For optimal performance and longevity, store Batteries at room temperature (71°F–82°F / 22°C–28°C).

NOTICE:

Battery compatibility for Dock charging and operation. The Dock for X10 Flight System requires Dock-compatible batteries in order to charge from the Dock. Batteries used in the controller-based configuration of the Skydio X10 Flight System are not chargeable from the Dock for X10. However, the system can still be flown using batteries from non-Skydio batteries. If the flight system detects a non-Skydio battery being used, the drone will return to the Safe Landing Point instead of the Dock when it is time to land, .

Inspection and Maintenance Intervals

Customer-Provided Maintenance

This section contains information about Customer-provided maintenance.

WARNING:

Risk of serious bodily injury or property damage due to improper maintenance. Failure to maintain the Skydio Dock for X10 Flight System may result in system performance failures. Annual maintenance and servicing internal components must be performed by Skydio-authorized technicians or Field Services teams. Failure to adhere to this guidance may increase the risk of serious bodily injury and/or property damage.

Important:

Drone maintenance and Dock for X10 Flight System software updates must be performed by the customer. This includes software updates for the X10 Drone, the Dock for X10, and the External Radio.

Customer X10 Drone Maintenance

Important:

Functional Check Flights (FCF) are recommended at the end of each maintenance cycle.

Maintenance Description	Maintenance Action	Responsibility	Maintenance Cycle
Software/Firmware Update	Installation	Customer	As system updates become available. Note: Release Notes are available on Skydio Support.
Navigation Camera Lens Cleaning	Cleaning	Customer	As-needed or during routine Drone service. Note: Cameras should be inspected regularly. If Drone Cameras are dirty and need to be cleaned, a notification may be received in Remote Flight Deck.

Maintenance Description	Maintenance Action	Responsibility	Maintenance Cycle
Propeller Replacement	Replacement	Customer	<p>Per 250 hours, or as-needed if damaged.</p> <p>Per 100 hours of flying with multiple attachments in high-stress flight conditions.*</p> <p>Note: Dock for X10 flight systems should be flown using REV 2 propellers.</p>
Battery Replacement	Replacement	Customer	<p>Per 300 battery cycles</p> <p>Note: A battery cycle is the depletion of at least 80% of the charge; an undamaged properly stored battery can be safely used beyond 300 cycles.</p>
Battery (if unused)	Charging	Customer	<p>Unused batteries require a single charge and discharge once every 2 months.</p>
Drone Attachments	Replacement	Customer	<p>3 years from the date of manufacture.</p>

* The duration between maintenance intervals for REV 2 Propellers will be extended as flight tests indicate safe use beyond 100 hours of high-stress flight time while configured with multiple attachments. When these changes occur, they will be announced in upcoming Flight System Updates and reflected in the Propeller device page in Skydio Cloud.

Important:

Any future extensions of propeller lifespans do not modify or limit preflight inspection requirements to ensure operational readiness prior to each flight.

Note:

High-stress use of the flight system with multiple attachments is defined as multiple attachments installed on the Drone, combined with:

- Sustained flight airspeed above 33 mph (53 km/h)
- Aggressive or max throttle, pitch, and yaw
- Flights conducted in high wind or gust conditions

Customer Dock for X10 Maintenance

Important:
FCFs are recommended at the end of each maintenance cycle.

Maintenance Description	Maintenance Action	Responsibility	Maintenance Cycle
Software Update	Installation	Customer	As system updates become available. Note: Release Notes are available on Skydio Support.
Dock Camera Lenses	Cleaning	Customer	As-needed or during routine Drone service Note: Cameras should be inspected regularly.

Skydio-Provided Maintenance

This section contains information about Skydio-provided maintenance.

Skydio Maintenance Responsibilities

Skydio Dock for X10 Flight System Annual Maintenance and As-Needed Repair Services must be performed by Skydio Authorized Technicians or Field Services teams.

Important:

Functional Check Flights are recommended at the end of each maintenance cycle.

DANGER:

Electrical hazard. Exposure to energized components can result in serious injury or death. Follow local/site specific lockout/tagout procedures for de-energizing the Dock and removing electrical hazards. Ensure the work area is clear of unnecessary personnel. If necessary, restrict access to the area.

Before performing service on the unit, do the following:

- Engage the Dock E-Stop button.
- Turn the Dock OFF.
- Disconnect the Dock from the AC power supply.
- Disconnect all external data and power cables from the Dock.
- Complete required lockout/tagout procedures per site requirements.

WARNING:

Risk of serious bodily injury or property damage due to improper maintenance. Failure to maintain the Skydio Dock for X10 Flight System may result in system performance failures. Annual maintenance and servicing internal components must be performed by Skydio-authorized technicians or Field Services teams. Failure to adhere to this guidance may increase the risk of serious bodily injury and/or property damage.

Maintenance Description	Maintenance Action	Responsibility	Maintenance Cycle
Annual Maintenance	Clean Dock Surfaces	Skydio	12 months after Installation date and every 12 months thereafter.
	Clean Dock Cameras	Skydio	
	Replace Filter	Skydio	
	Replace Belt Dampers	Skydio	
	Replace Charger (if needed)	Skydio	
	Tighten Platform Hinges	Skydio	
	Re-clamp User Panel Magnet	Skydio	
	Conduct physical inspection	Skydio	
	Run diagnostic tests	Skydio	
As-Needed Repairs	Repair or replace a malfunctioning field replaceable unit (FRU)	Skydio	As-needed in the event that a unit is malfunctioning or damaged.

Dock for X10 Flight System Annual Inspection and Maintenance

After one year of operational use from the date of Installation, the Dock for X10 Flight System is eligible for an Annual Maintenance Inspection and Service. This service is conducted by Skydio Authorized Technicians or Field Services teams.

Annual Service visits can be scheduled by contacting Skydio Support.

The Annual Maintenance Inspection includes:

- Diagnostic Test (automated, technician-facing)
- Visual Inspection
- Repair of worn or damaged internal parts
- Drone inspection
- Intake filter replacement
- Functional Check Flight

To contact Skydio Support, see: [Skydio Support \(on page 87\)](#)

General Care

This section contains information about general care.

Overview

The Dock for X10 Flight System has a 5-year operational lifespan. During that time, the Flight System requires regular care and maintenance.

Important:

The maintenance actions outlined in this section are essential to maintaining system operability and are the responsibility of the customer.

The tasks described in this document are to be performed by the Owner/Operator, and are not included in Field Services packages.

Preflight Inspection

A preflight inspection is required prior to every operational use of the flight system.

Important:

If issues are identified during inspection that would impact safe use, cease operations and conduct necessary maintenance.

Functional Check Flights

Upon completion of each maintenance interval and prior to returning the system to operations, a Functional Check Flight (FCF) is required.

Upon completion of each maintenance activity, it is best practice to conduct an FCF and create a maintenance log entry.

Note:

For more information related to FCFs and Maintenance Logs, read the [Functional Check Flights \(on page 78\)](#) and [Maintenance Logs \(on page 86\)](#) sections in this manual.

Diagnostics and Troubleshooting

For assistance with diagnostics and troubleshooting, contact Skydio Support. See: [How-To: Contact Skydio Support \(on page 87\)](#).

Flight System Health

This section contains information about Health and Connectivity statuses.

Health Status (Fleet Page)

The Fleet Page provides a snapshot overview of each flight system, including information related to sensor packages and attachments.

Important:

If a device is in **Limited Operation** or **Inoperable**, the system may require maintenance.

For a preview about an issue, hover over the device status (ex. Front Camera Failure). For recommended actions, navigate to the Device Page.

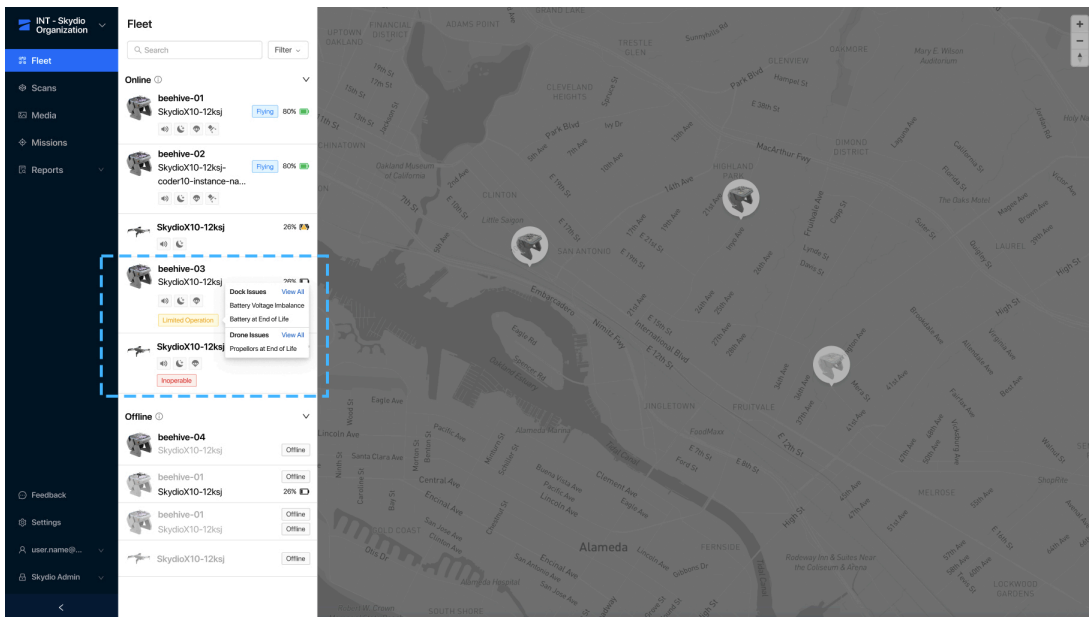

Criteria	Definition
<p>Inoperable</p>	<p>Refers to device health.</p> <p>A critical issue is preventing flight; immediate action required.</p>
<p>Limited Operation</p>	<p>Refers to device health.</p> <p>Some functionality is restricted. Depending on the issue, the system may still be airworthy, but maintenance is needed soon.</p>

Criteria	Definition
No Known Issues	Refers to device health. Functioning as expected.

Connectivity Status

Refers to network connectivity health and appears on the Flight System page (Fleet > Select the name of the Dock).

Criteria	Definition
Online	Refers to network connectivity health. The system is connected and ready for flight.
Offline	Refers to network connectivity health. System is disconnected.

Diagnosing Flight System Issues in Skydio Cloud

A critical issue may not always render the Flight System inoperable if the affected component or module is not classified as critical to flight operation.

Note:

While Skydio Support should be contacted for further guidance, not all issues will require a Field Services Technician onsite for internal component replacement.

Example: A Flight System in the fleet is marked as Limited Operation. Hovering over this Limited Operation tag indicates that the X10 propellers need to be replaced. This maintenance action should be performed by the appropriate personnel at the customer's organization. Follow internal maintenance protocols, log the maintenance action, and perform a successful Functional Check Flight prior to resuming normal flight operations.

Device Pages

This section contains information about Device Pages.

Individual **Device Pages** enable monitoring of system health, including the following:

- Drones
- Docks
- External Radios
- Batteries
- Controllers

Note:

It is recommended that Device Pages be reviewed during preflight inspections.

Individual Device Pages provide a centralized view of the following:

- Connectivity Status
- Health Overview
- Outstanding Issues (aka. Issue Cards)
- Suggested Resolutions
- Other information relevant to the specific device type

Each Device page contains three menu tabs:

- [Overview \(on page 20\)](#)
- [Connectivity \(on page 23\)](#)
- [Settings \(on page 25\)](#)

How-to: Access Device Pages

There are two ways to access a Device Page:

Note:

For X10 Drones and Dock for X10 only.

Option 1

1. Log in to Skydio Cloud. <https://cloud.skydio.com/entry/login>
2. Navigate to the Fleet page.

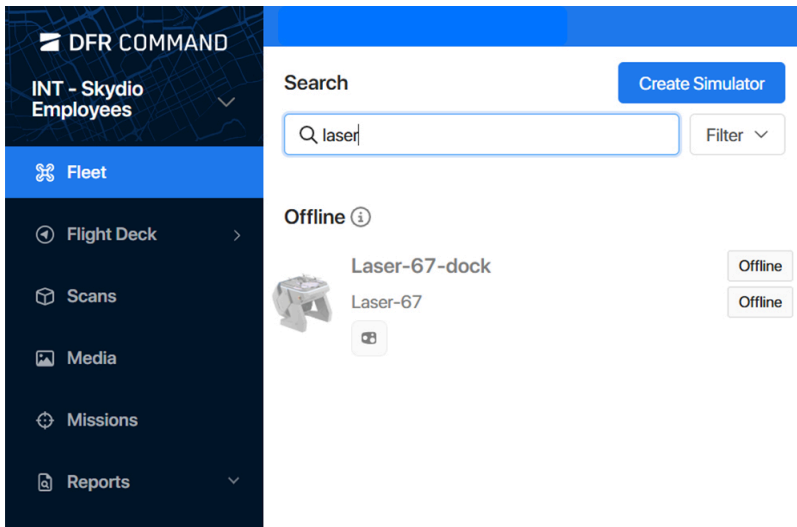

3. Select a device.

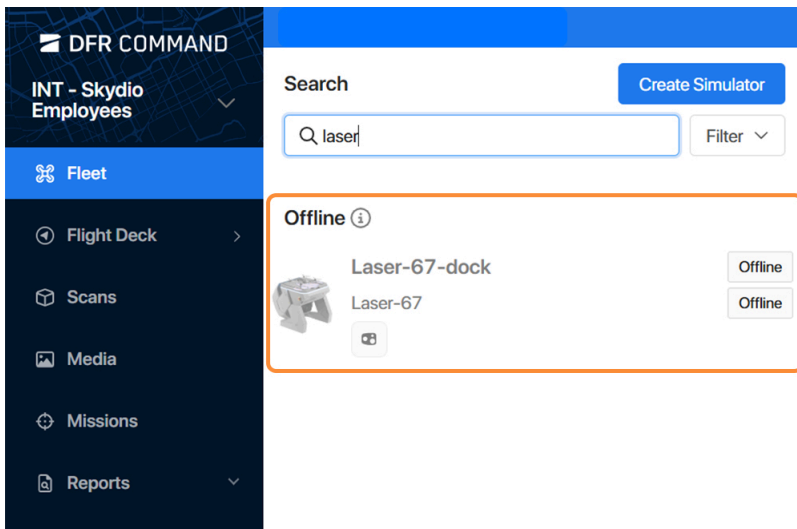

4. To view the Device Page, click the gear icon next to the device's name.

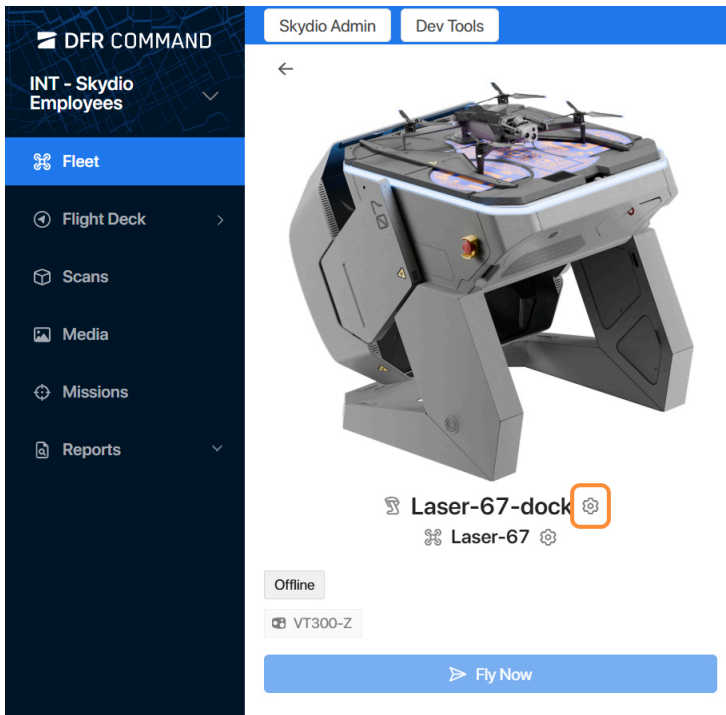

Option 2

1. Log in to Skydio Cloud. <https://cloud.skydio.com/entry/login>
2. Navigate to Settings > Devices.

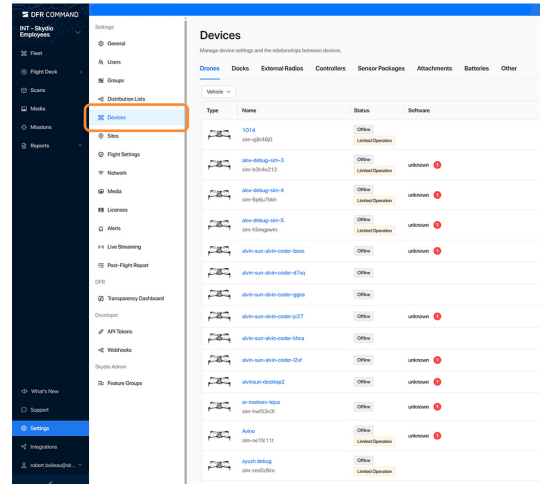
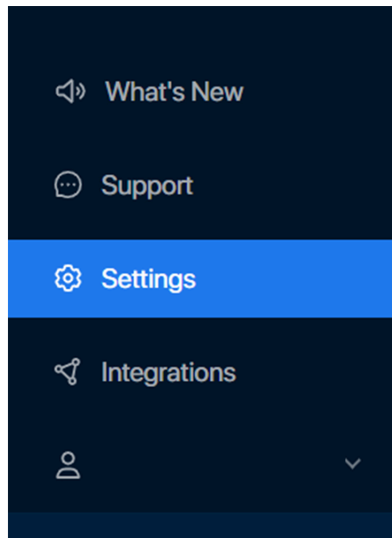

3. Select the type of device from the top menu.

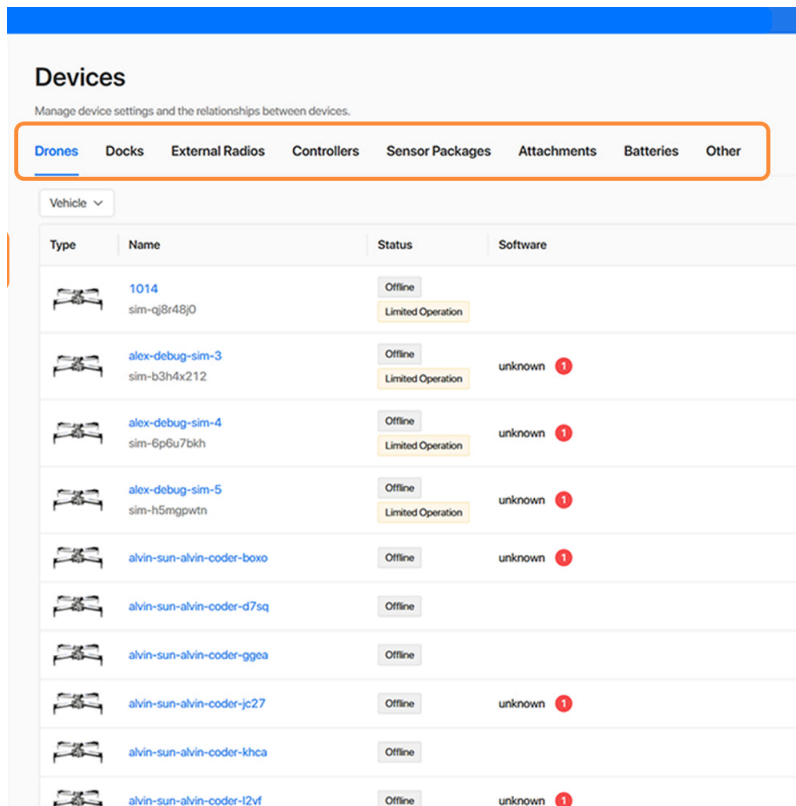

Overview

This section contains information about the Device Page Overview tab.

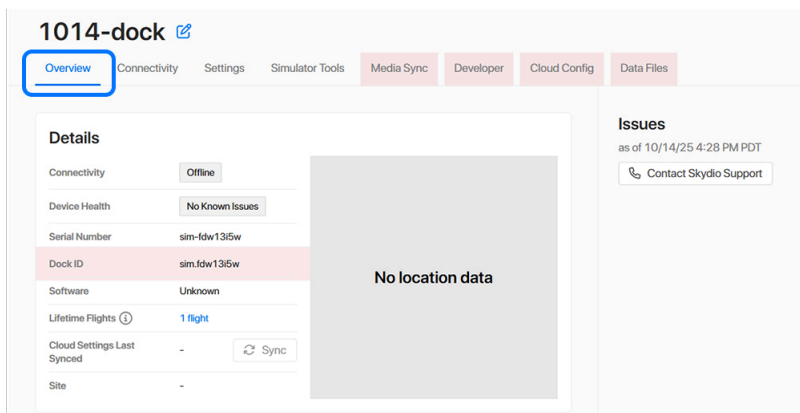

Device Pages provide a centralized, real-time view of a device’s status, location, health, software, and key operational details.

Details

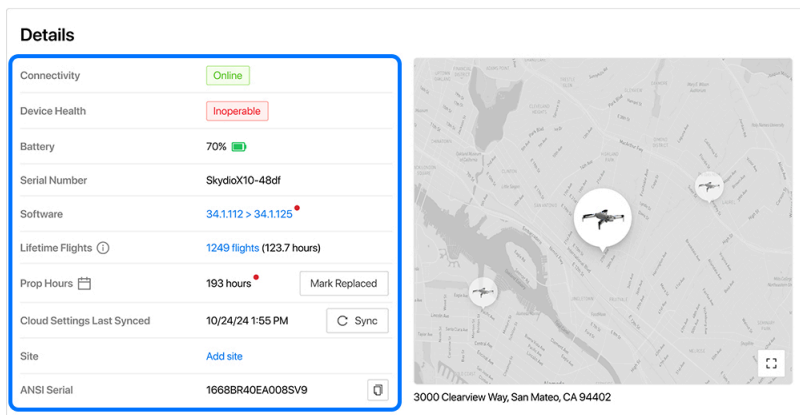

Criteria	Definition
Connectivity	Current network status.
Device Health	Status of the device (ex. Dock, Drone, External Radio).
Battery (Drone pages)	Current charge level.
Serial Number	Device alphanumeric identification number.

Criteria	Definition
Software	<p>Current software version of the individual device</p> <p>Important: A red notification dot means there is an update available. Select the software version to open the Settings tab and initiate an update.</p>
Lifetime Flights	Total number of flights in this organization.
Prop hours (Drone pages)	<p>Tracks the total propeller hours based on flight time.</p> <p>Note: Does not indicate prop health.</p>
Cloud Settings Last Synced	<p>Time and date of the most recent sync.</p> <p>Tip: Click on the Site name to enter the Site editor.</p>
Site (Dock pages)	Displays the name of the Site.
ANSI Serial	The device's unique identifier used for Remote ID and registration purposes, particularly with the FAA.

Flight System

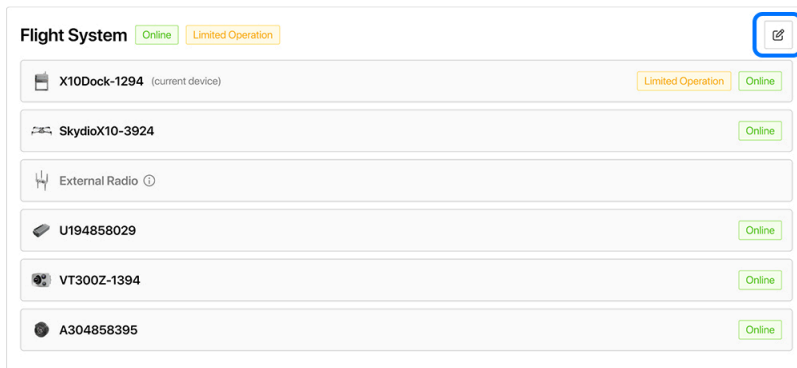

Flight System displays the following:

- Batteries
- Attachments
- Sensor Packages
- Health Status

To link a new device, select the **Edit** icon.

Issues

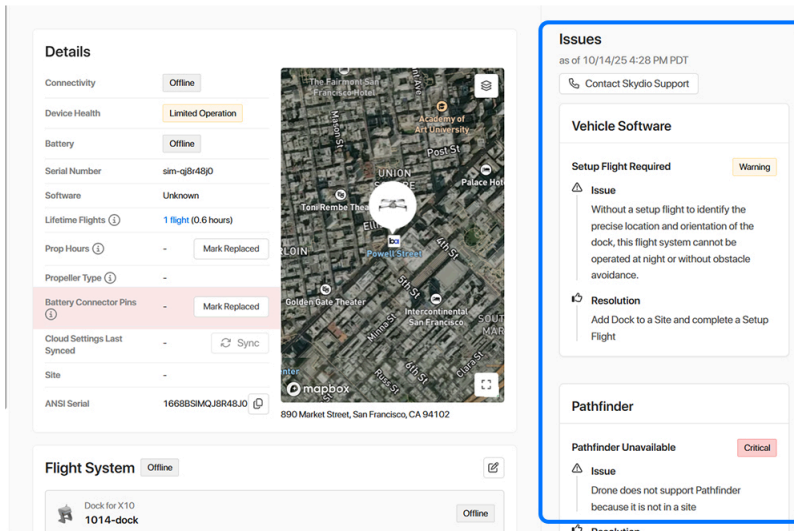

If a Device is in **Limited Operation** or **Inoperable**, the Issues section will provide:

- Issue descriptions detailing diagnostic faults.
- Severity assessments based on operational impact.
- Recommended actions to address the issue.

Note:

To view contact information, use **Contact Skydio Support**.

Connectivity

This section contains information about the Device Page Connectivity tab.

The image below shows the Connectivity tab of a Drone Device Page.

The screenshot displays the 'Connectivity' tab of a Drone Device Page. At the top, there are three navigation tabs: 'Overview', 'Connectivity' (which is selected and underlined), and 'Settings'. The main content area is divided into four sections:

- Network Details:** A table showing network information:

MAC Address(es)	3a:1d	[Copy]
IP Address(es)	-	
Carrier(s)	T-Mobile	
ICCID	0000000000	[Copy]
- Connect Fusion:** A section with a note: "Note: Connect Fusion settings are kept synced between each linked dock, drone, and external radio". It features a toggle for 'Connect 5G' which is currently turned on. Below the toggle are two buttons: 'Restore Default' and 'Save'.
- Streaming:** A section with three rows of streaming URLs, each with a copy icon:

Color	rtsp://stream.skydio.com/SkydioX10-1234/color	[Copy]
Thermal	rtsp://stream.skydio.com/SkydioX10-1234/thermal	[Copy]
Live Telemetry	wss://stream.skydio.com/data/SkydioX10	[Copy]
- Speed Test:** A section with a 'Start' button and a 'Vehicle' label. Below the 'Vehicle' label are three buttons: 'Downlink' (highlighted in blue), 'Uplink', and 'Media Sync'.

Criteria	Definition
Network Details	Displays MAC and IP addresses, cellular carriers, and SIM card Integrated Circuit Card Identifiers (ICCID).
Connect Fusion (Drone pages)	<p>Enables or disables Connect 5G.</p> <p>When enabled, system will use Connect Fusion to encode separate streams for both Connect SL and Connect 5G, then dynamically select the strongest feed in real-time.</p>
Streaming	Provides streaming links for Real Time Streaming Protocol (RTSP).
Speed Tests	<p>Measures data transfer performance between a device and Skydio Cloud. Assesses the quality of network communication and diagnoses issues related to connectivity or data throughput.</p> <hr/> <p>Downlink: Measures the data transfer rate from the Drone to Skydio Cloud.</p> <p>Note: Useful for evaluating how quickly telemetry, video streams, and logs can be uploaded from the Drone to the Skydio Cloud.</p> <hr/> <p>Uplink: Measures the data transfer rate from Skydio Cloud to the Drone.</p> <p>Note: Useful for assessing responsiveness and how quickly mission updates or configuration changes can be sent to the Drone.</p> <hr/> <p>Media Sync: Performance of high-throughput transfers during media synchronization.</p> <p>Note: Useful for photos or video file uploads from the Drone to Skydio Cloud.</p>

Settings

This section contains information about the Device Page Settings tab.

The Settings menu is used to manage general settings for a given device.

Licenses, Tools, and Pathfinder

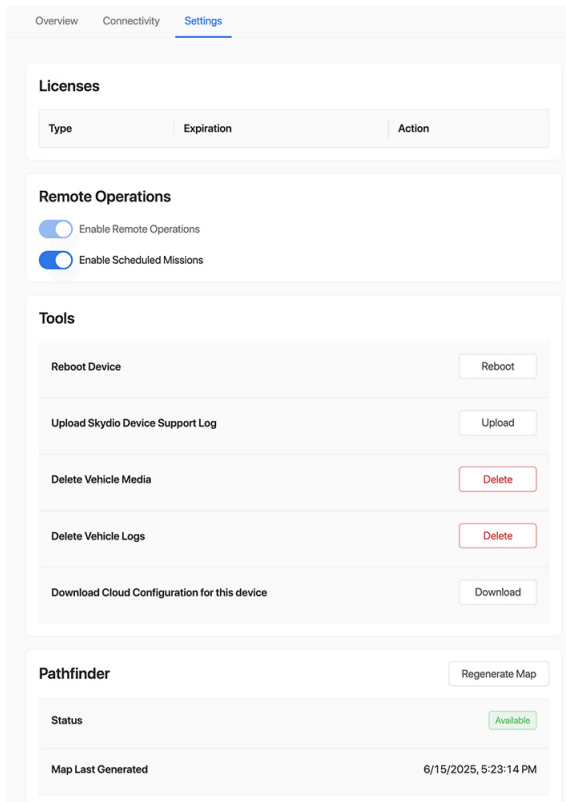

Criteria	Definition
Licenses	Lists all active licenses associated with the flight system.
Remote Operations	<p>The following options are available:</p> <ul style="list-style-type: none"> • Enable Remote Operations: <p>Note: Enabled by default for Dock and remote operations.</p> • Enable Scheduled Missions: Allows the selected flight system to perform pre-planned missions <p>Note: Created from the Missions tab in Skydio Cloud.</p>

Criteria	Definition
Tools	<p>The following options are available:</p> <ul style="list-style-type: none"> • Reboot: Remotely restarts the selected device. Selecting this power-cycles the device, terminating all active processes and connections before initiating a clean restart. <p>Note: Device Support Logs may be requested during interactions with Skydio Support.</p> <ul style="list-style-type: none"> • Upload Skydio Device Support Log: Attach a device support log to aid troubleshooting and support cases. • Delete Vehicle Media: Permanently delete media from a vehicle’s storage to free space or remove sensitive captures. • • Delete Vehicle Logs: Permanently delete on-vehicle logs to free storage or remove sensitive diagnostics. • Download Cloud configuration for this device: Export the device’s current Cloud configuration for audit, backup, migration, or support.
Pathfinder	<p>Review the Pathfinder map status and regenerate it. The following statuses apply:</p> <ul style="list-style-type: none"> • Red: No Pathfinder map is available and nothing is being generated. <p>Note: It is advised to regenerate the map.</p> <ul style="list-style-type: none"> • Yellow: New map is being generated. <p>Note: The start date of the artifacts generation workflow is displayed, helping users know if everything is on track.</p> <ul style="list-style-type: none"> • Green: A pathfinder map is available and all generation processes are complete. <p>Note: The date of the most recent available map is displayed if one is present.</p>

Lights and Sounds

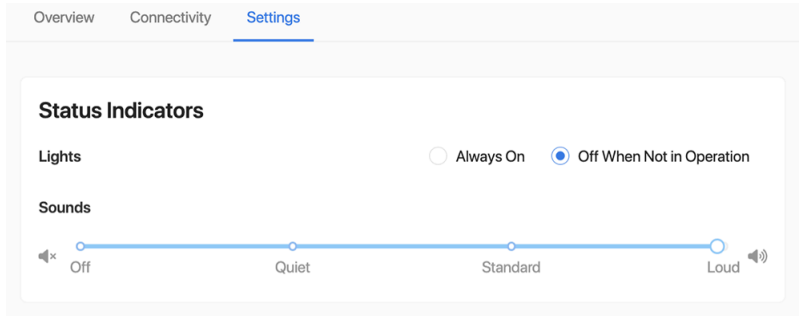

Criteria	Definition
Dock Device Settings	Status Indicators
Lights	Select between: <ul style="list-style-type: none"> • Always On • Off When Not in Operation
Sounds	Select between: <ul style="list-style-type: none"> • Off • Quiet • Standard • Loud

How-To: Clean the Dock for X10 Flight System

This section explains how to clean the Dock for X10 Flight System.

Required Items

Parts

Qty	Item	Part Number	SKU
1x	Roof Enclosure	850-209870-000	N/A
1x	Base	N/A	N/A
1x	Legs	N/A	N/A
1x	Asy, Led Strip, Base Perimeter	850-209589-000	DR4EDOKFRU13
1x	Rain Sensor	TBD	TBD
1x	Anemometer (Wind Sensor)	850-210687-000	DR4EDOKFRU5
1-2x	SA Camera Module (Front / Rear)	850-209536-000	DR4EDOKFRU4
1x	Asy, Inspection Camera Module	850-210136-000	DR4EDOKFRU10
1x	Asy, Platform	850-210141-000	DR4EDOKFRU16

Fasteners and Consumables

Qty	Item	Part Number	Torque / Notes
	N/A		

Tools

Qty	Item	Part Number	Notes
1x	Water Spray Bottle	N/A	
1x	Lens Cleaner	N/A	
1x	Glass Cleaner	N/A	
1x	Microfiber Towels	N.A	

Safety Information

DANGER



Motorized Dock for X10 moving parts
Moving parts may close or move unexpectedly.
Pinch points will cause serious injury or death.
Ensure the work area is clear of unnecessary personnel.
Maintain a 7.0 ft (2.1 m) distance from all moving mechanisms.
Obey all labels and warnings on the Dock.
Follow local/site specific lockout/tagout procedures for de-energizing the Dock.

Preparation

1. Turn the Dock for X10 Off.
 - a. Open the User Panel.

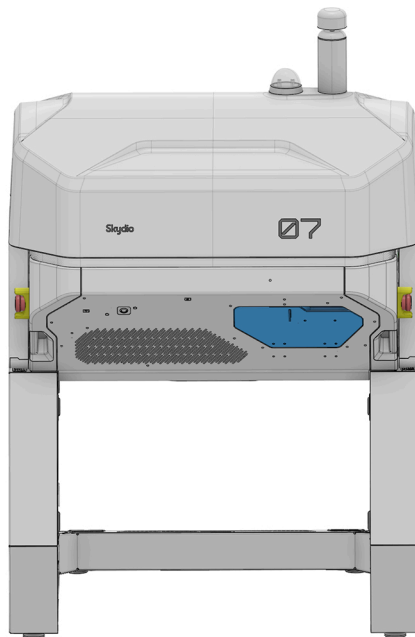

b. Turn off the Dock by switching the power toggle off ('O' position).

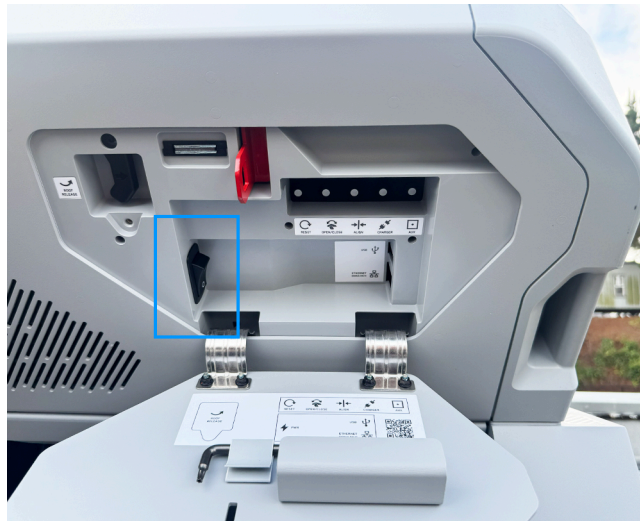

c. Close the User Panel.

2. Engage one or both E-Stop Buttons.

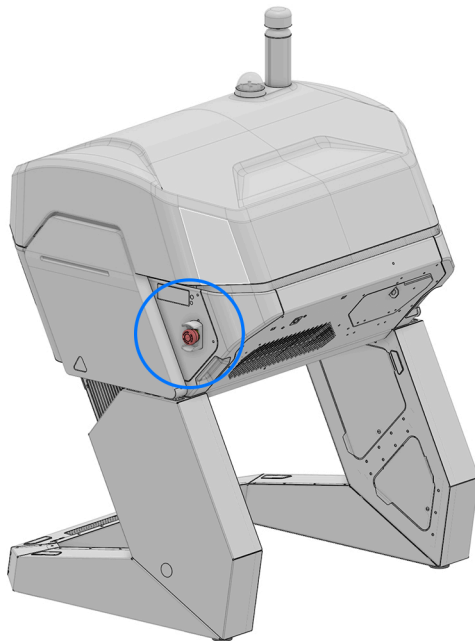

Dock Cleaning Procedure

Clean the Dock for X10 on an as-needed basis depending on environmental conditions. If the Dock is located in an area with excessive wind, dirt, or dust, the customer may need to clean the surfaces to ensure the external cameras remain clear.

Note:

The Dock for X10 will also be cleaned during the routine Annual Service that is conducted by a Skydio-certified technician.

Use only water or approved lens/glass cleaners where specified.

Important:

Do NOT use soap or cleaning agents on any part of the Dock.

Note the following:

- It is acceptable to hose down the exterior of the Dock when the Roof is closed, if the Dock is heavily soiled (ex. post-storm conditions).
- The area beneath the platform may appear dirty or stained. This is expected and does not require detailed cleaning.

To clean the Dock for X10, do the following:

1. Wipe down the entire Dock for X10 with a damp cloth.

Clean all surfaces until visibly free of dust, debris, and streaks:

- Roof Enclosure
- Base
- Legs

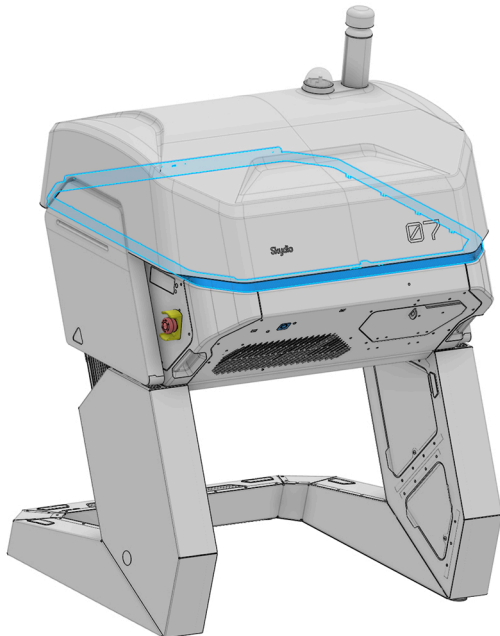

2. With the Roof both closed and open, wipe the Dock Perimeter Lights with a damp cloth.

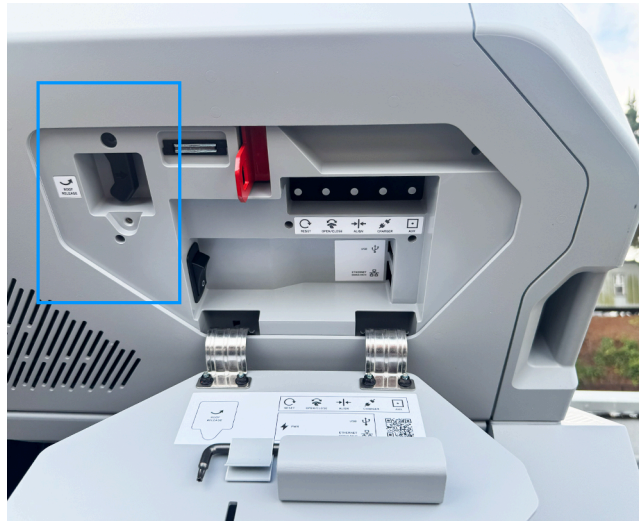

- a. To release the Roof Latch, pull the Roof Latch handle.
To manually open the Roof with the Dock turned OFF, do the following:



- b. Manually lift the Roof and allow it to slide fully open.

 CAUTION	
	<p>Risk of damage to Anemometer or Rain Sensor during roof operation. Potential damage to the Anemometer or Rain Sensor. When manually opening or closing the roof of the Dock, do not grab the Roof by the Anemometer or Rain sensor.</p>

- 3. To clean the Rain Sensor, do the following:
 - a. Gently wipe the sensor with a damp cloth.
 - b. Dry the sensor with a microfiber cloth.

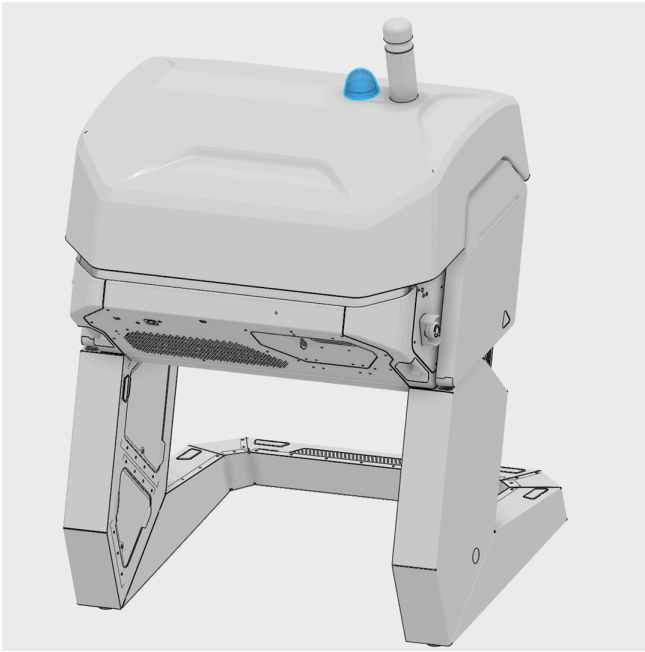

4. Gently wipe the underside of the Anemometer using a lens cleaner.

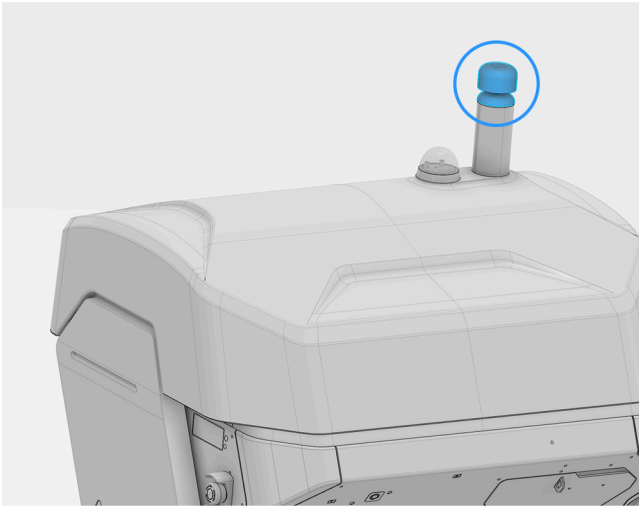

5. Clean the Dock Cameras.

- Clean the front Camera.

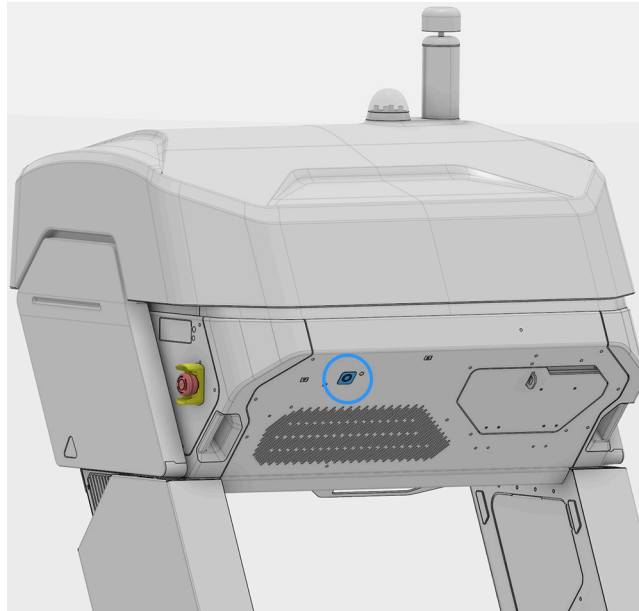

- Manually open the Roof and clean the Inspection Camera.

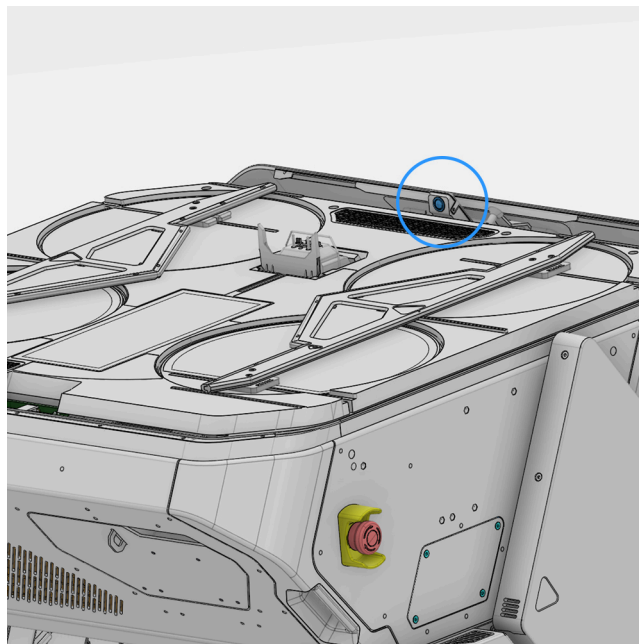

- If present, clean the Rear Camera.

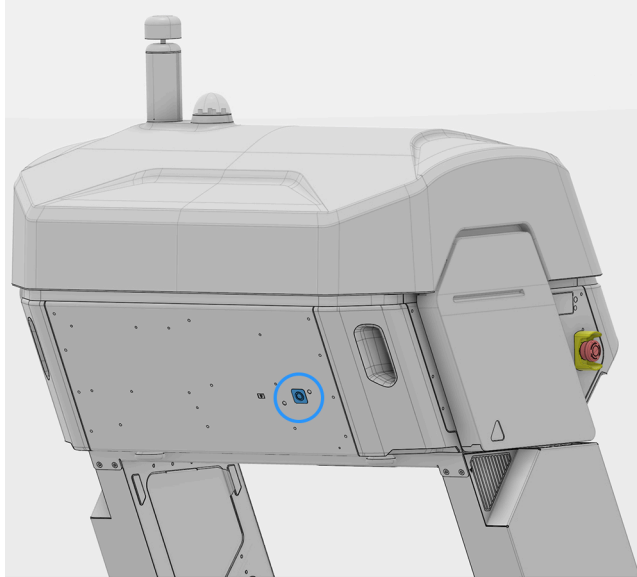

For each Camera, do the following:

Note:

Glass cleaner wipes may also be used.

- a. Lightly spray the camera lens with water.
- b. Let the water droplets run off naturally.
- c. Gently wipe the lens with a damp cloth.
- d. Dry the lens with a microfiber cloth.

6. Clean the Platform.

- With the Roof open, wipe the Platform surface with a damp cloth and microfiber towel until visibly free of dust, debris, and streaks.
- Clean the outer Platform Fences with Isopropyl Alcohol (IPA) 70% or greater wipes.

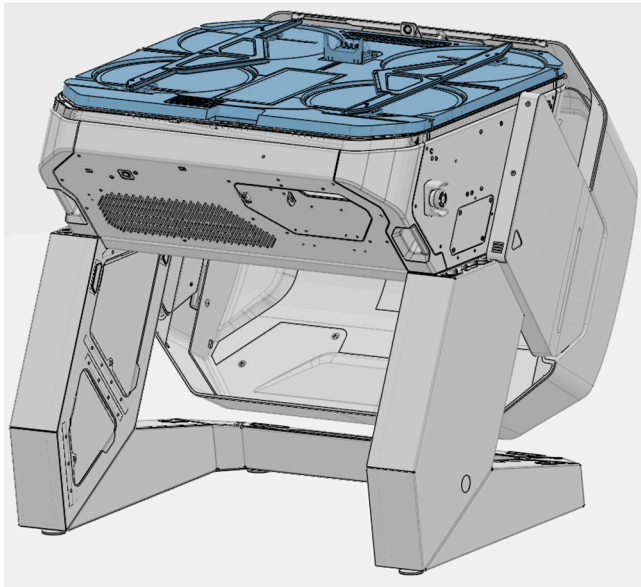

Monitoring and Routine Maintenance

This section contains information about how to monitor Flight System health and provide routine maintenance.

Regular monitoring and maintenance ensure continued performance of the Dock for X10.

Monitor system health in Skydio Cloud: Faults or performance issues generate notifications in Skydio Cloud. For alerts related to component status, regularly check **Settings > Equipment > Docks**.

Review environmental conditions: Certain serviceable units such as the Thermal Exchange Cooler (TEC) and weather sensors, rely on optimal environmental conditions. Monitor deployment locations for excessive dust, debris, or extreme temperatures that may impact performance.

Inspect for physical damage or debris buildup: Periodically inspect Parts such as filters and sensors for obstructions or wear that could reduce efficiency.

Follow replacement guidelines: If a component shows persistent faults, degraded performance, or repeated error notifications, reach out to Skydio Support.

Replacing a Drone and Returning to Operations

This section explains how to replace a Drone and return it to operations.

In the event that a Skydio X10 Drone is replaced under warranty or Skydio Care, the replacement Drone needs to be claimed in Skydio Cloud and linked to the Dock.

Claim and Link Devices

To manage a fleet of Skydio Flight Systems, hardware devices must be claimed and linked so that they can receive updates and are associated with the customer's Skydio Cloud organization.

Note:

For organizations with large fleets, a designated Customer Success Manager can assist in bulk claiming new Skydio Drones and batteries in Skydio Cloud.

Claiming devices enables tracking usage metrics and assigning additional software licenses. Hardware to claim includes:

- Drones
- Docks
- External Radios
- Controllers
- Sensor Packages
- Attachments
- Batteries

CAUTION:

Risk of equipment misconfiguration or operational failure. Do not attempt to pair a Dock-assigned drone with a Skydio X10 Controller, as this configuration is not supported. If pairing is absolutely necessary, extensive reconfiguration is required and must be coordinated through Skydio Support.

How-To: Claim a Device

This section explains how to claim a device.

1. Select **Settings > Devices**
2. Select **Claim Device**
3. Enter the **Device Name**

Depending on the device to be claimed, enter either the UAV name, serial number, or battery serial number.

4. **Optional:** Rename the device.

Device names display on the Fleet Page and during operations. To name a device:

- a. Locate the device to rename from the **Devices** tab.
- b. Click the three dots.

- c. Select **Change Settings**.
- d. Rename and Save.

How-To: Locate a Drone Name and Battery Serial Number

This section explains how to locate a Drone name and Battery serial number.

Skydio X10 UAV Name and **Battery Serial Number** can be found on the regulatory and identification label inside the battery bay of the Drone.

Label Location

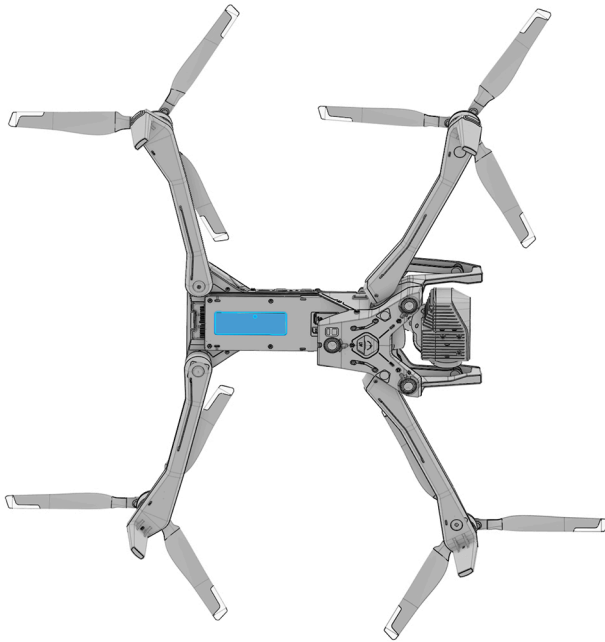

- The **UAV Name** begins with `skydioX10-` and is located on the upper-left side of the label.

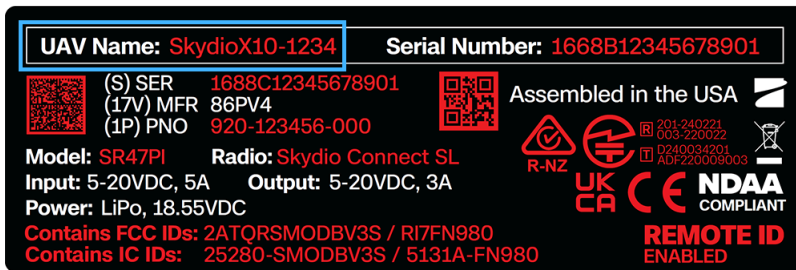

- The 16-digit **Serial Number** is located on the upper-right side of the label.

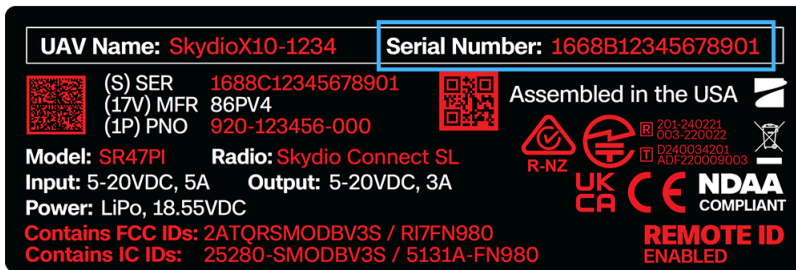

How-to: Link Devices

Ensure all Flight System Parts have been claimed:

- Skydio X10
- Dock for X10
- External Radio

1. Open the Dock for X10 Device Page.

From the **Overview** tab locate the **Flight System** section.

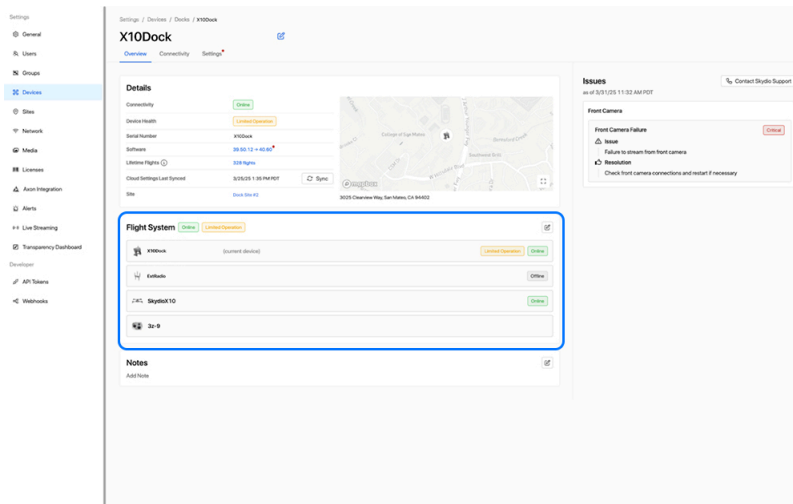

2. Edit the Flight System.

To view a drop-down list of linkable devices, click the edit icon in the upper right.

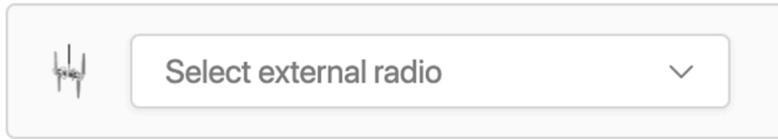

3. Link devices.

a. Select the relevant external radio and Drone from the drop-down menu.

b. To apply, click **Save**.

The devices will link when next connected to the internet.

4. To ensure the Flight System is operating properly, complete a Preflight Inspection and Functional Check Flight.

[Functional Check Flights \(on page 78\)](#)

How-To: Sensor Package Replacement

This section explains how to remove and install a Sensor Package.

Required Items

Parts

Qty	Item	Part Number	SKU
1x	VT300-Z <ul style="list-style-type: none"> • 64MP Wide • 48MP telephoto <p>Note: Cameras have lossless zoom and advanced image processing.</p>	DR4SAFEVT300Z	N/A
1x	VT300-L <ul style="list-style-type: none"> • 64 MP narrow module • 50 MP 1" wide module • LED flashlight • FLIR Boson+ radiometric module 	DR4GIMKTVT300L	N/A
1x	V100-L <ul style="list-style-type: none"> • 64 MP narrow module • 50 MP 1" wide module • LED flashlight 	DR4GIMKTV100L	N/A

Fasteners and Consumables

Qty	Item	Part Number	Torque / Notes
4x	M2.5 Captive Screws	N/A	28 cNm

Tools

Qty	Item	Part Number	Notes
1x	Skydio Torque Tool (2 mm, 28 cNm)	DR4ACCTT	

Safety Information

While a sensor package can be replaced, this process is not intended to be performed frequently or in the field. Only do so when necessary, and follow the steps outlined below.

Sensor Package Removal

This section explains how to remove the Sensor Package.

For reference, see the following video: [X10 Getting Started - How to Install and Uninstall a Sensor Package](#).

1. Remove the Gimbal Stabilizer Clip.

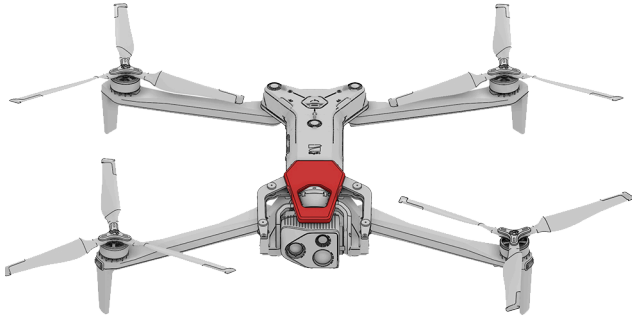

2. Remove the X10 Battery.
[Battery Removal \(on page 68\)](#)

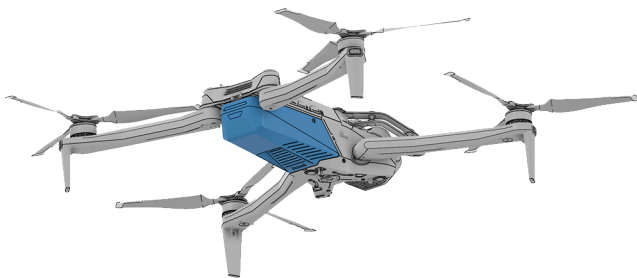

3. Loosen 4x Sensor Package fasteners.

- a. Unfasten 4x captive M2.5 Hex screws with a 2 mm hex tool.
Use the tool provided in the Sensor Package kit.

Note:

The 4x fasteners are captive screws and remain attached to the Sensor Package.

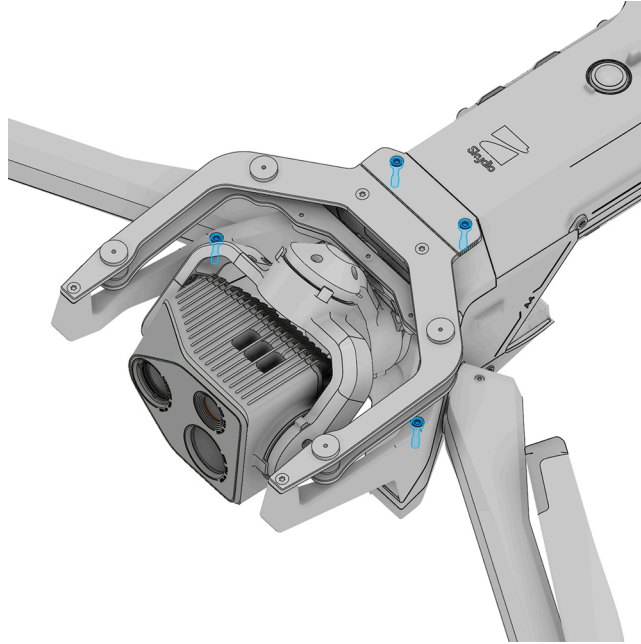

4. Remove the sensor package.

- a. Hold the edges of the Sensor Package Frame.

Important:

Do not lift on the sensor package itself.

- b. Lift the Sensor Package Frame up while gently rocking it side-to-side until it is completely free and clear of the guide posts on the X10 Drone.

Note:

This helps the Sensor Package disengage from 2x electrical connections on the airframe.

CAUTION:

Risk of equipment damage. Improper handling during Sensor Package replacement may damage the housing, the drone frame, or electrical connection points. To remove or install, lift or lower the Sensor Package up/down vertically. Do not pull the Sensor Package off at an angle. Do not use a peeling motion when removing the Sensor Package.

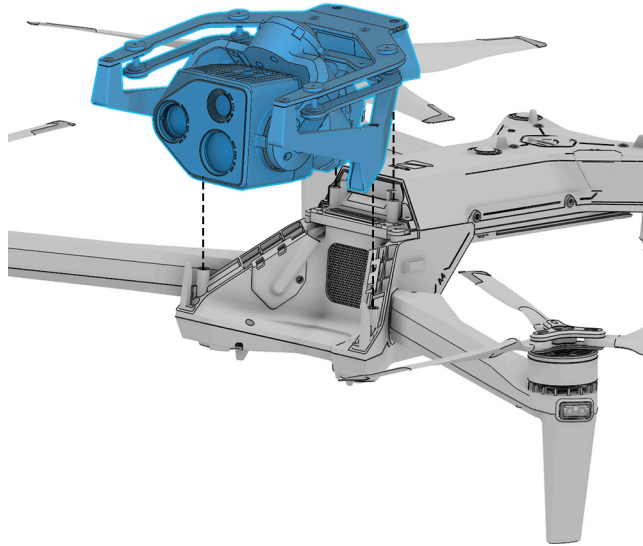

5. For safe storage, attach the gimbal stabilizer clip to the removed Sensor Package.

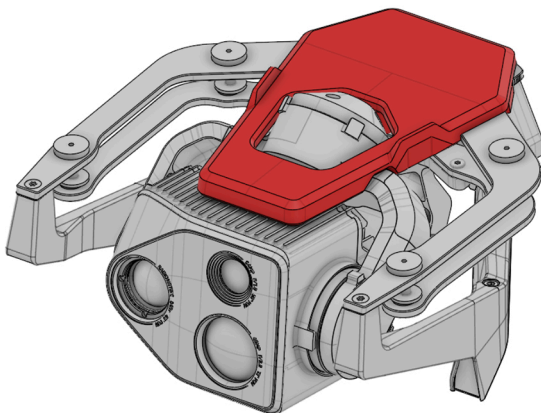

Sensor Package Installation

This section explains how to install the Sensor Package.

Ensure the Battery is removed from the X10 Drone.

1. Remove the Gimbal Stabilizer Clip to the Sensor Package.

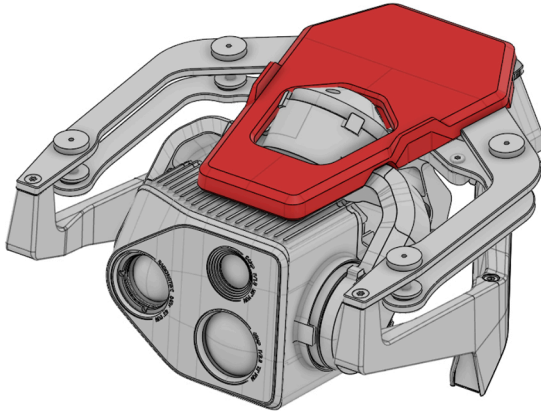

2. If present, remove the Gimbal Connector Plug from the Sensor Package.

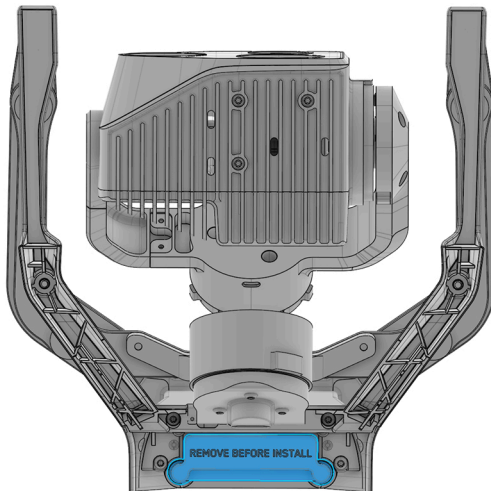

3. Install the Sensor Package.

- a. Hold Sensor Package Frame by the outside edges.

Important:

Do not directly handle the sensor package or cameras.

- b. Align 2x datum holes on the underside of the Sensor Package with 2x datum pins on the Drone.

Note:

This helps the Sensor Package electrical connector align with electrical connector on the Drone.

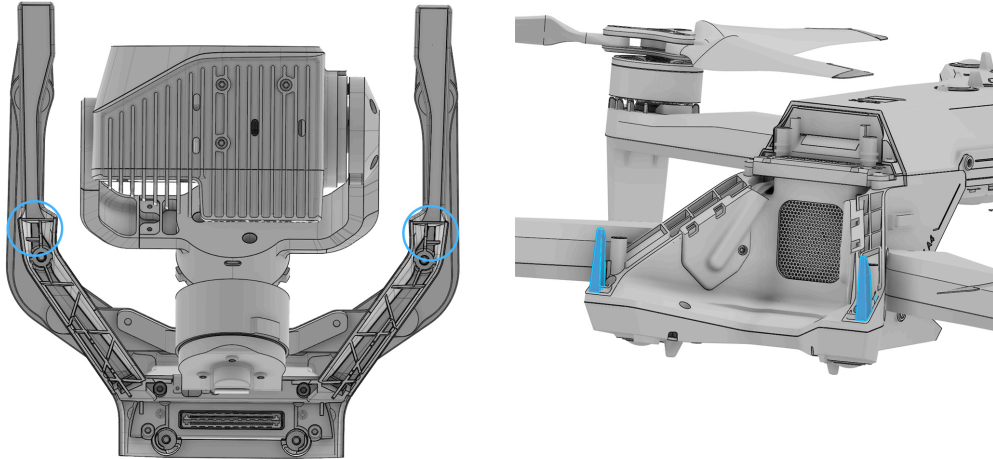

- c. Lower the Sensor Package Frame on to the Drone and firmly press down between the two screws on the top plate until the Sensor Package locks into place.

CAUTION:

Risk of equipment damage. Improper handling during Sensor Package replacement may damage the housing, the drone frame, or electrical connection points. To remove or install, lift or lower the Sensor Package up/down vertically. Do not pull the Sensor Package off at an angle. Do not use a peeling motion when removing the Sensor Package.

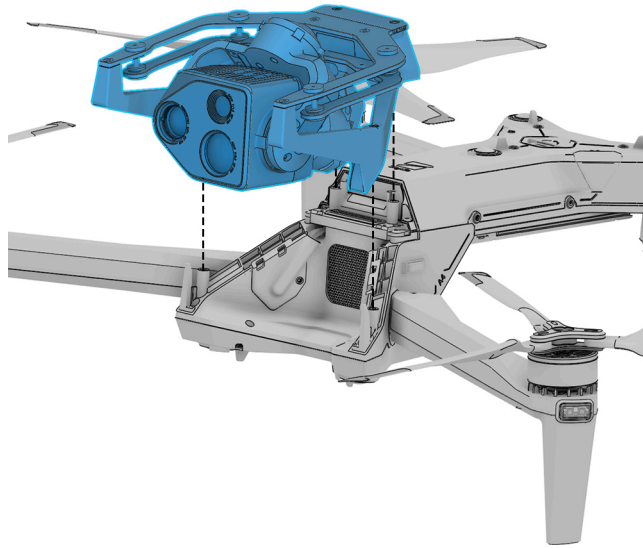

d. Ensure 4x captive M2.5 Sensor Package screws align with 4x fastener holes on the Drone.

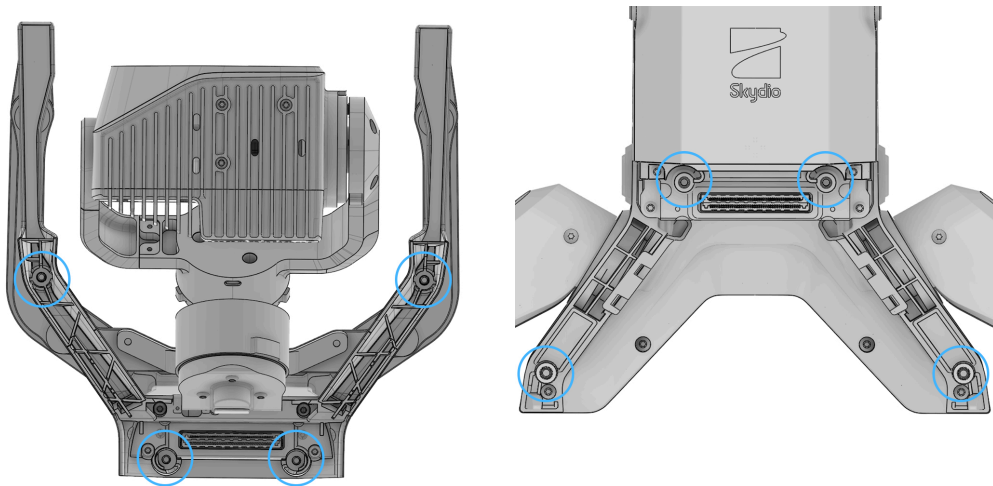

4. Install 4x Sensor Package fasteners.

- a. Torque 4x captive M2.5 Hex screws with the Skydio Torque Tool (2 mm, 28 cNm) or a 2 mm hex tool.
Torque: 28 cNm Nm.

Note:

If using the Skydio Torque Tool, the tool will "click" once the screws are fully torqued to specification.

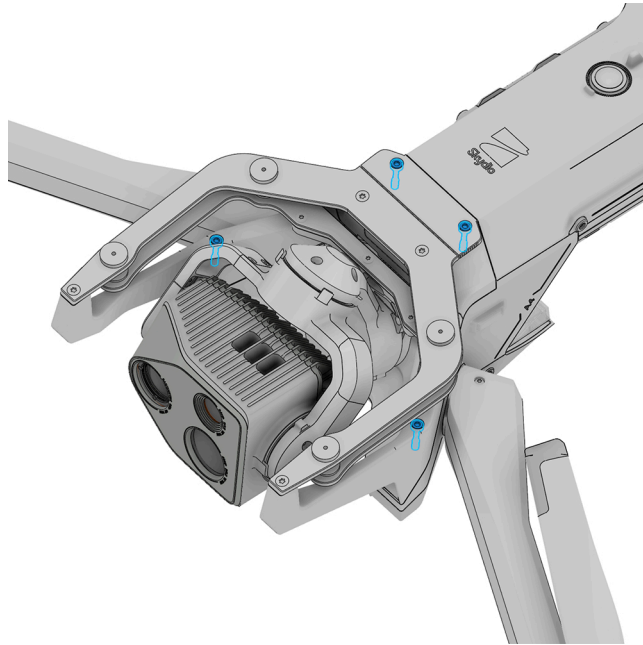

5. Install the X10 Battery.

[Battery Installation \(on page 69\)](#)

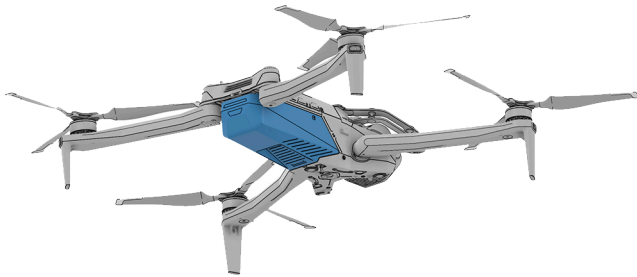

Functional Verification

This section explains how to verify functionality.

Complete a Functional Check Flight.
[Functional Check Flights \(on page 78\)](#)

Customer Maintenance Actions

Propeller Spring Inspection - X10 Drone

This procedure explains how to inspect propeller Springs on the X10.

Safety Information

This section contains relevant safety information.

WARNING:

Risk of serious injury or loss of control from propellers. Keep all limbs and body parts away from the Skydio X10 drone while it is in motion or in flight. Contact with moving propellers can cause severe injury or death. Never fly with damaged propellers. If cracks, nicks, bends, or other visible damage are found, do not proceed with flight. Skydio recommends replacing all four propellers at once prior to the next flight.

Inspection Process

This section explains preliminary steps required before the procedure.

1. Inspect 4x Propellers Springs.

If all conditions are true, the drone propeller springs must be replaced:

- Spring is damaged or broken in pieces.
- The motor spins freely while hand spinning.

Note:

If the motor does not spin freely, contact the Skydio Advanced Support team for next steps, as the drone will need to come back to Skydio for repair.

2. To request spare parts for Spring repair, contact the Skydio Advanced Support team.

How-To: Propeller Spring Replacement - X10 Drone

This procedure explains how to replace a damaged propeller Spring on the X10.

Required Items

Parts

Qty	Item	Part Number	SKU
4x	Motor	N/A270-209121-000	N/A

Fasteners and Consumables

Qty	Item	Part Number	Torque / Notes
1x	Skydio X10 Propeller Spring Replacement Kit (6 Springs)	TBD	N/A

Tools

Qty	Item	Part Number	Notes
1x	Painter's Tape		
1x	Tweezers		

Safety Information

This section contains relevant safety information.

WARNING:

Risk of serious injury or loss of control from propellers. Keep all limbs and body parts away from the Skydio X10 drone while it is in motion or in flight. Contact with moving propellers can cause severe injury or death. Never fly with damaged propellers. If cracks, nicks, bends, or other visible damage are found, do not proceed with flight. Skydio recommends replacing all four propellers at once prior to the next flight.

Preparation

This section explains preliminary steps required before the procedure.

1. Inspect 4x Propellers Springs.

If all conditions are true, proceed with the Spring Repair Procedure:

- Spring is damaged or broken in pieces
- The motor spins freely while hand spinning.

Note:

If the motor does not spin freely, contact the Skydio Advanced Support team for next steps, as the drone will need to come back to Skydio for repair.

2. To request spare parts for Spring repair, contact the Skydio Advanced Support team.

Spring Repair Procedure

For each broken Spring, do the following:

1. Remove 1x propeller from the drone.
[How-To: Propeller Replacement - X10 Drone \(on page 58\)](#)
2. Cover the Propeller Motor with 4x pieces of tape.
To prevent debris from entering the motor, ensure that the openings of the motor are not visible.

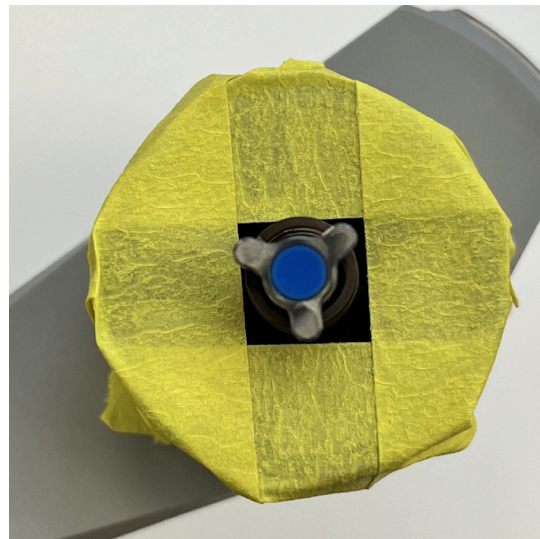
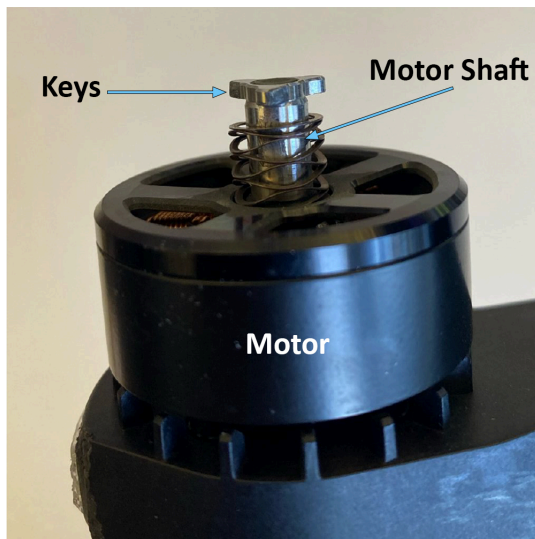

3. Remove 1x broken Spring.

CAUTION:

Risk of debris entering the Motor. While removing Springs, ensure the tweezers do not puncture the tape.

Use plastic tweezers to do the following:

- a. While holding the base of the motor, use tweezers to separate the end of the Spring and hook it over the first key.

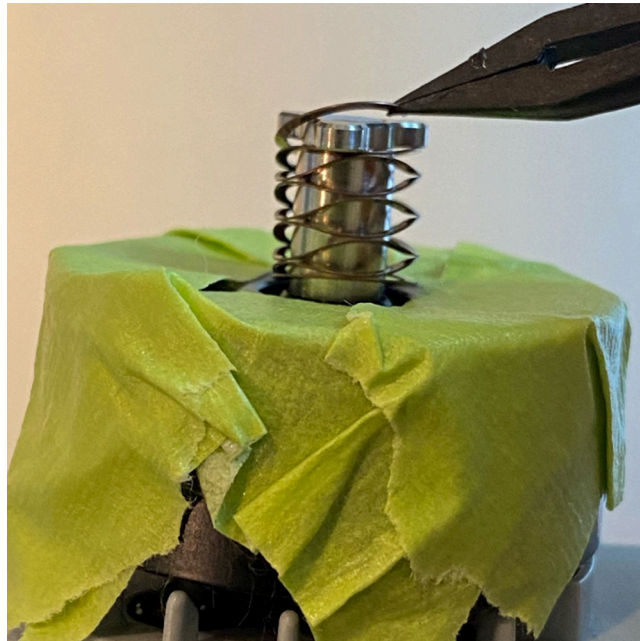

- b. Hook the Spring on top of the second key.

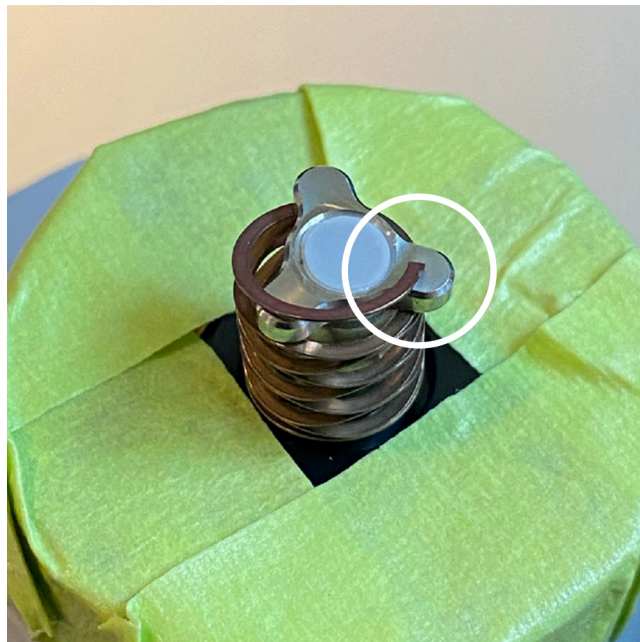

- c. Hook the Spring on top of the third key.



- d. Twist the Spring off of the key by hand.
Continue until the Spring is completely removed from the motor shaft.

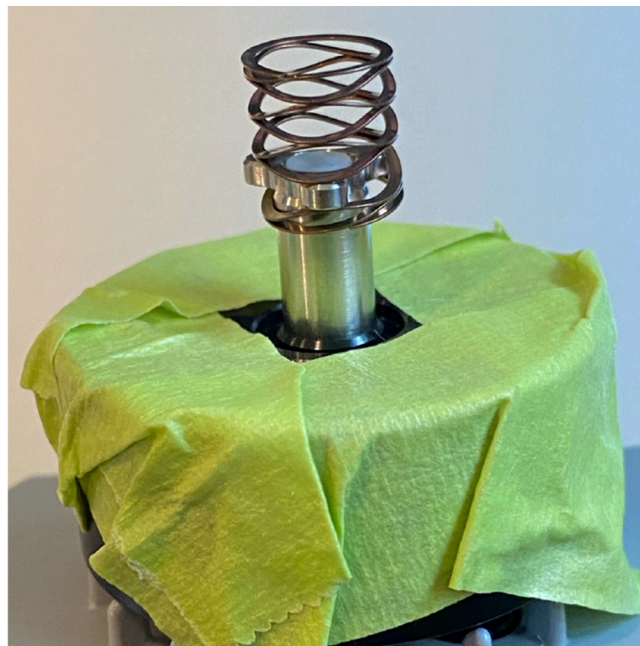

- 4. Verify there are no broken Spring parts inside the drone by flipping X10 upside down.
Perform a visual inspection and remove any Spring pieces from the crevice.

- a. Visually inspect for any Spring pieces.



- b. Remove broken Spring pieces using tweezers or fingers.

5. Install 1x new Spring.

- a. Gently pull apart the end of the Spring with tweezers or fingers.
b. Hook the Spring under the first, second, then third key and twist clockwise (down).

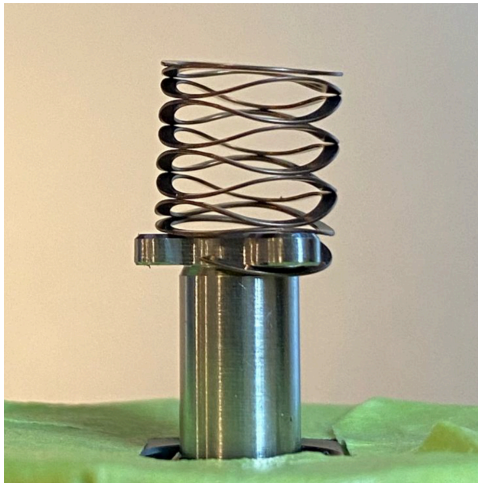

- c. Ensure the Spring stays upright and aligned with the motor shaft.
d. Twist clockwise until the Spring is fully installed.

CAUTION:

Risk of Spring damage. During installation, do not bend the springs or use excessive force.

6. Once the Spring is fully seated on the Motor Shaft, remove the tape.

Ensure the following:

- No tape residue is present on the Hub.
- In order to fly, the surface must be clean.

7. Install the propeller following the Skydio support article.
[How-To: Propeller Replacement - X10 Drone \(on page 58\)](#)
8. Repeat the above procedure for additional broken or damaged Propeller Springs.

Functional Verification

Verify the propeller spins smoothly.

How-To: Propeller Replacement - X10 Drone

WARNING:

Risk of serious injury or loss of control from propellers. Keep all limbs and body parts away from the Skydio X10 drone while it is in motion or in flight. Contact with moving propellers can cause severe injury or death. Never fly with damaged propellers. If cracks, nicks, bends, or other visible damage are found, do not proceed with flight. Skydio recommends replacing all four propellers at once prior to the next flight.

For optimal performance, Skydio recommends replacing propellers for the following reasons:

- After 250 hours of flight time
- Whenever damage is identified
- After 100 hours of flight time, if flying with multiple attachments in high-stress flight conditions

Important:

Dock for X10 flight systems should be flown using REV 2 propellers.

The total number of flight hours for an X10 Drone is tracked in the Drone Device Page within Skydio Cloud.

Propeller Replacement

Tip:

For ease of tracking total Propeller flight time, replace all propellers at the same time.

1. Remove the old or damaged propeller set.
 - a. Hold onto the motor with one hand and take the propeller hub in the other.
 - b. Press down on the propeller hub and twist to release.

Note:

Depending on the motor orientation on the Drone, it may be required to twist clockwise or counter-clockwise.

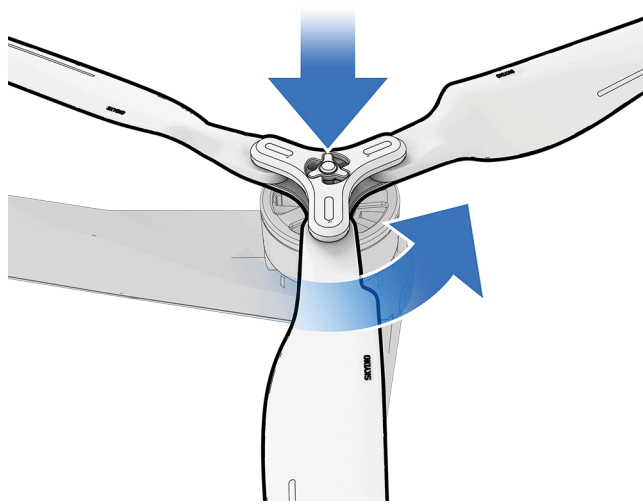

c. Pull the Propeller off of the Motor.

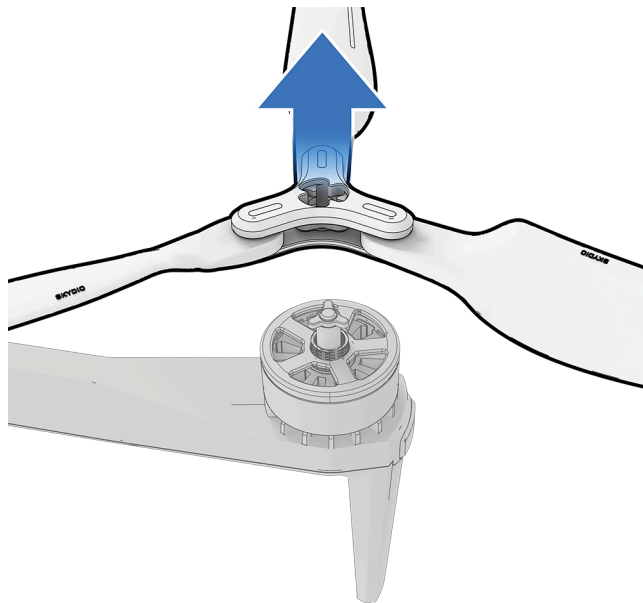

2. Identify the Propeller set that matches the Motor.

Match the replacement set of propellers to the color on the Motor.

3. Inspect all Motors for any dirt or debris.

4. Install a new Propeller set.

Important:

When installing, do not force the Propellers into place. If the propeller set does not fit on the Motor it might be the incorrect set or side.

- a. Hold onto the motor with one hand and take the propeller hub in the other.
- b. Align the opening on the hub with the motor.

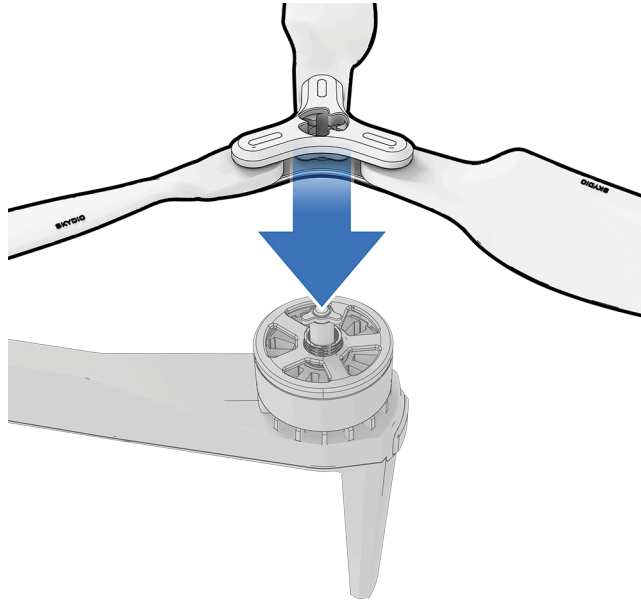

- c. Press down and twist to lock in place.

Note:

Depending on the Motor orientation on the Drone, it may be required to twist clockwise or counter-clockwise.

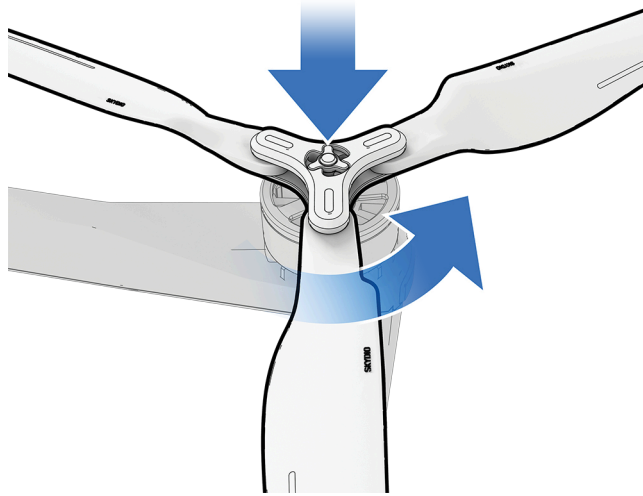
**5. Visually inspect the Propellers and X10 Drone.**

Do the following:

- Ensure all propellers free of cracks, nicks, bends, or other visible damage.
- Inspect the condition of visible Motor hubs.
- Inspect the condition of the Drone body
- Ensure the Drone arms are properly aligned and fully extended.
- Ensure the battery is fully seated and secured.
- Ensure any attachments are fully seated, secured, and connected.
- Ensure any unused attachment bays are closed with rubber seals.

6. After replacing a propeller set, ensure that an Organization Admin updates the **Prop Hours field within the Drone Device Page.**

[Tracking and Updating Propeller Hours \(on page 62\)](#)

Tracking and Updating Propeller Hours

This section explains how to track and update Propeller hours in Skydio Cloud.

WARNING:

Reduced flight safety. Exceeding recommended propeller flight hours can result in propeller failure, equipment damage, or loss of aircraft control. Track propeller flight hours. Regularly inspect propellers. Replace propellers within specified service limits.

For propeller replacements, Skydio Cloud enables users to count the Drone Propeller flight hours from the time of replacement. This helps users track maximum flight hours.

If a propeller is damaged, breaks, or when the Drone reaches its recommended interval for prop replacement, replace all 4x props on the Drone. Log the replacement in Skydio Cloud with the **Mark Replaced** button. This will update the date and time and restart the counter.

To begin tracking:

1. Click **Mark Replaced**, in **Prop Hours**.

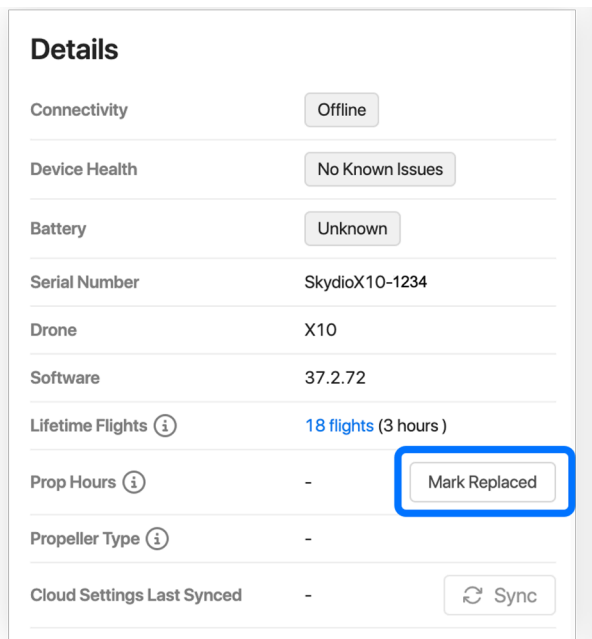

2. From the Select the Propeller **Type**.

Note:

Dock for X10 flight systems use REV 2 Propellers.

Update Propeller Details ×

Safety Notice ×
Always replace propellers in full matching sets of 4 to maintain accuracy and safety

Current propeller details

Type -

Installation Date -

Operation Time 5 hours

Select new propeller type

REV 1 old

REV 2 new

Select propeller replacement date

May 16, 2025 2:52 pm

Cancel Update

3. Enter the date and time of the last replacement in the **Installation Date** field.

Important:

If a dash "-" is present within the **Vehicle Device Page**, it means no date has been entered. Enter the date of the most recent replacement.

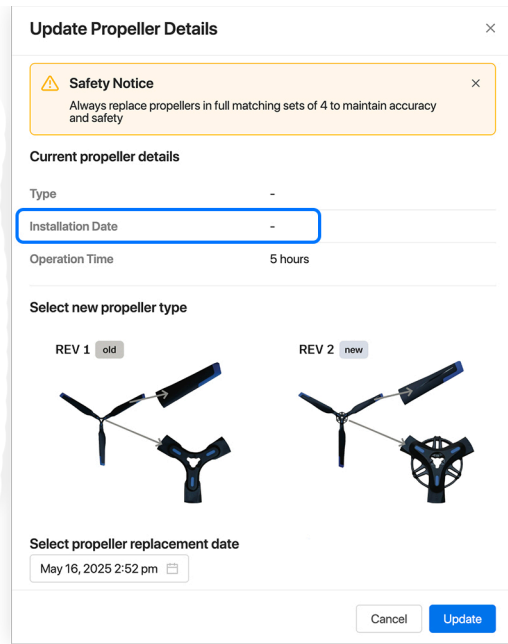

4. Click **Update**.

Once completed, Skydio Cloud will begin tracking the propeller flight hours.

When Skydio X10 Propellers exceed 250 hours of use, a notification will appear under the **Issues** panel on the **Device Page**.

For optimal performance, Skydio recommends replacing propellers for the following reasons:

- After 250 hours of flight time
- Whenever damage is identified
- After 100 hours of flight time, if flying with multiple attachments in high-stress flight conditions

X10 Drone Battery Maintenance

This section contains information about X10 Drone Battery Maintenance.

Skydio X10 Batteries are shipped in a hibernation state and will not power on Drone out of the box. During Dock installations, Skydio Deployment Engineers will exit the Battery hibernation.

To view warranty information, see: [Skydio Limited Warranty](#).

Battery Maintenance Cycle

This section contains information about the Battery Maintenance Cycle.

A Battery maintenance cycle should be performed every **2 months**.

To complete Battery maintenance cycle, do the following:

- Fully charge and discharge the batteries.
- Fly in a controlled environment until the Drone reaches the Low Battery landing threshold.

If Batteries have been stored for an extended period of time (longer than 2 months), a maintenance cycle is required.

Note:

For information about Battery Storage, see: [Battery Storage \(on page 65\)](#).

Battery Storage

This section contains information about storing Batteries.

WARNING:

Risk of fire, explosion, or injury from extreme environmental conditions. Exposure to extreme heat or cold can cause cell rupture, thermal runaway, or fire resulting in serious injury or property damage.

Do not charge, use, or store batteries in the following conditions:

- Extreme temperatures (below 14°F / -10°C or above 140°F / 60°C)
- Direct sunlight
- Inside hot vehicles

CAUTION:

Risk of Battery damage from improper storage conditions or low state of charge. Do not store Batteries at a very low state of charge (< 30%). Before long-term storage to prevent irreversible cell damage, charge Batteries to approximately 50%. Keep unused batteries in a cool, dry area with less than 75% relative humidity. For optimal performance and longevity, store Batteries at room temperature (71°F–82°F / 22°C–28°C).

Batteries that are attached to a Skydio X10 Drone and stationed inside a Dock for X10 are kept in a controlled environment that meets approved storage temperature standards.

Important:

If State of Charge (SOC) is greater than 50%, the battery will automatically begin self discharging after 14 days. In an effort to retain capacity, Batteries in an idle state (14 days of idle time with no flights) will begin to self-discharge. Self-discharge may take several days to complete and it is normal for the Battery to be slightly warm during the process.

Important:

If storing Batteries not attached to a Drone and outside of a Dock, ensure they are charged to at least 50% SOC.

How-To: Battery Replacement

This section explains how to remove and install a Battery on an X10 Drone.

NOTICE:

Battery compatibility for Dock charging and operation. The Dock for X10 Flight System requires Dock-compatible batteries in order to charge from the Dock. Batteries used in the controller-based configuration of the Skydio X10 Flight System are not chargeable from the Dock for X10. However, the system can still be flown using batteries from non-Skydio batteries. If the flight system detects a non-Skydio battery being used, the drone will return to the Safe Landing Point instead of the Dock when it is time to land, .

For optimal performance, Skydio recommends replacing Batteries every 300 charging cycles.

Note:

A battery cycle is the depletion of at least 80% of the charge. An undamaged and properly stored battery can be safely used beyond 300 cycles.

In-Warranty Batteries

While still under warranty, if a battery exhibits defects, damage, or other issues, contact Skydio Support for assistance.

Tip:

To help expedite the evaluation process when submitting a support request, include clear photos of the Battery or any visible damage.

Out-of-Warranty Batteries

If a Battery is no longer under warranty, contact a Skydio Account Executive to purchase a replacement.

Required Items

Parts

Qty	Item	Part Number	SKU
1x	Battery	DR4ACCBAT	N/A

Fasteners and Consumables

Qty	Item	Part Number	Torque / Notes
	N/A		

Tools

Qty	Item	Part Number	Notes
	N/A		

Battery Removal

This section explains how to remove a Battery from an X10 Drone.

Skydio X10 Batteries are secured using a magnetic connection.

To remove the Battery from the Drone, do the following:

1. Firmly grip the Drone chassis with one hand.
2. Grip the Battery with the other hand, placing a palm over the power button while wrapping a thumb under the Battery.
3. Using fingers as leverage, do the following:
 - a. Press against the Drone until the magnets disengage.
 - b. Slide the Battery away from the Drone.

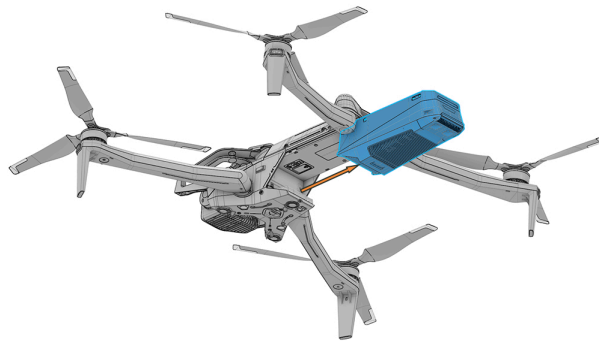

To dispose of a Battery, see: [Battery Disposal \(on page 70\)](#).

Battery Installation

This section explains how to install a Battery on an X10 Drone.

To install the Battery, do the following:

1. Prior to installing the Battery, ensure the connection pins and the Battery bay on the Drone are free of damage and debris.
2. Align the battery with the rails and slide it toward the Drone until the magnets engage.

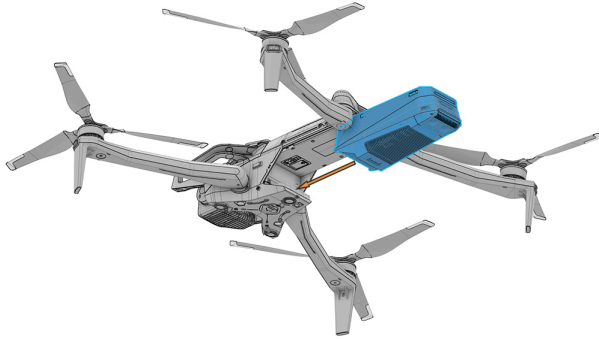

3. Before flying, ensure the Battery is fully seated and secured to the Drone.

Functional Verification

To ensure the Battery functions properly, turn the Drone on.

Battery Disposal

This section explains how to properly and safely dispose of Batteries.

WARNING:

Risk of fire, explosion, or injury from damaged or improperly handled batteries. If a battery shows signs of damage, such as substantial gouging or cracking of the plastic housing, place it in a non-flammable enclosure away from people and contact a local hazardous waste recycling agency for safe handling and disposal. Do not dismantle, open, or shred batteries. Do not dispose of batteries in regular garbage or recycling bins. Lithium polymer batteries must be disposed of only at certified electronic waste or battery recycling facilities. Never include batteries in burned waste. Lithium polymer batteries contain flammable materials that can cause explosive fires when overheated and may re-ignite due to thermal runaway. Do not store batteries in metal containers without appropriate insulation. Store damaged and undamaged batteries separately in temperature-controlled, non-conductive containers.

The Skydio X10 Drone and Battery are NOT considered common waste. Dispose of electronic waste and lithium polymer batteries in accordance with all applicable local laws and regulations.

Sending a Battery to Skydio

This section explains how to send Batteries back to Skydio, when requested.

WARNING:

Risk of fire, explosion, or injury during shipment of lithium-ion batteries. Unless requested by Skydio as part of a Return Material Authorization (RMA) process, do NOT return batteries to Skydio. If requested to return batteries to Skydio, follow the instructions provided by Skydio customer support for safe handling and transport. Do not ship damaged or leaking batteries. Ship batteries only in compliance with all applicable IATA, DOT, and local transport regulations. Discharge batteries to 30–50% state of charge before shipment.

Do the following:

- Cover terminals
- Package each battery separately in non-conductive material
- Label packages as “Lithium-ion Batteries, UN3480/UN3481.”

If Skydio requests the return of a faulty battery, a special **return box** and prepaid **ground shipping label** will be provided. The box contains special flame retardant liners that must surround the battery. A tracking number will also be assigned to the outbound shipment.

Important:

The box can only be shipped by UPS ground using the shipping label provided.

The box is properly labeled for **UN3480 hazardous materials**, which include:

- Drone battery packs when shipped loose
- Lithium-polymer batteries
- High-capacity battery packs
- Individual rechargeable lithium-ion cells



Flight System Software, Firmware, and Skydio Cloud Updates

This section contains information about Flight System Software, Firmware, and Skydio Cloud Updates.

Skydio regularly releases updates across the entire Flight System. Updates may deliver new features, improve performance, or resolve any diagnostic issues. A single release may include a variety of updates across different parts of the system.

Releases are accompanied by release notes, which explain both new and improved features as well as known limitations and bug fixes. Release notes provide important details about how the updates will affect operations.

When a new release is published, customers will receive an email notification as well as in-Cloud alerts. A red notification dot will appear on the individual Device Page when an update is available.

Important:

To ensure safe and effective operations, it is the customer's responsibility to read the release notes and keep the flight system updated.

Definitions

Software Updates

A Software Update modifies or replaces programs that run on top of the device's operating system. They are intended for high level device functionality that controls how the Drone, Dock, or software applications operate (ex. updated autonomous behavior).

Firmware Updates

Firmware Updates modify low-level code that directly controls device hardware operation. They apply to physical Parts such as Drones, Docks, or External Radios.

If there is an update available for the flight system, a red notification dot will be present in the following locations:

- Next to the gear icon on the Flight System Page
- Next to the version number in the Device Page

Skydio Cloud Updates

Updates the Skydio Cloud platform, which could include minor interface improvements or new features.

Updates to Skydio Cloud occur automatically.

When an update is released, there will be a red notification dot next to the **What's New** menu on the left sidebar. To read a summary of the release and follow the link to the full release notes, select **What's New** in the left sidebar menu.

Update Sequence

Update devices in the following order:

1. **X10 Drone** [How-To: X10 Drone Software/Firmware Updates \(on page 74\)](#)
2. **External Radio** [How-To: External Radio Software/Firmware Updates \(on page 76\)](#)
3. **Dock for X10** [How-To: Dock for X10 Software/Firmware Updates \(on page \)](#)

How-To: X10 Drone Software/Firmware Updates

This section explains how to complete a software or firmware update on the X10 Drone.

Update Via Skydio Cloud

Before updating, ensure the Drone is fully charged. For update downloading, connect to WiFi or a stable internet connection.

1. Turn the Skydio X10 Drone on.
Press and hold the Battery button for 3 seconds.

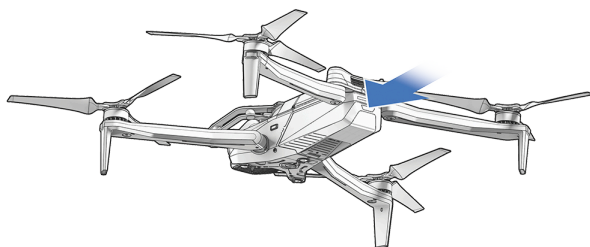

2. Login to Skydio Cloud.
<https://cloud.skydio.com/entry/login>

3. Navigate to **Settings > Devices**.

4. Select the applicable Drone's **Device Page**.

If an update is available, it will be indicated next to the Drone's name.

5. Click **Update**.







To update the Drone, follow the on-screen prompts.

Important:

Do NOT power off the Drone or exit the application while the update is in progress.

During the update, the lights (LEDs) on the Drone will indicate update status:

Update Status	LED Description	Images
Initializing	Solid Yellow	
0% - 12%	Front Left Arm Flashing Yellow	

Update Status	LED Description	Images
12% - 25%	Front Left Arm Solid Yellow Rear Left Arm Flashing Yellow	
25% - 37%	Front Left Arm Solid Yellow Rear Left Arm Solid Yellow Rear Right Arm Flashing Yellow	
37% - 50%	Front Left Arm Solid Yellow Rear Left Arm Solid Yellow Rear Right Arm Solid Yellow Front Right Arm Flashing Yellow	
50% - 100%	Breathing Yellow Note: LEDs may flash on and off during 50% - 100%.	
Complete	Solid Green	
Error	Flashing Red	

Important:

After download and installation, the Drone will automatically reboot.

6. Upon reboot, re-connect to the Drone and verify the updated is correct.
7. After all Parts have been updated and before returning the flight system to normal operations, complete a Functional Check Flight.
[Functional Check Flights \(on page 78\)](#)

How-To: External Radio Software/Firmware Updates

This section explains how to complete a software or firmware update on the External Radio.

Update Via Skydio Cloud

1. Login to Skydio Cloud.

<https://cloud.skydio.com/entry/login>

2. Navigate to **Settings > Devices**.

3. Select the applicable External Radio **Device Page**.

If an update is available, it will be indicated next to the device name.

4. Click **Update**.

5. After all Parts have been updated and before returning the flight system to normal operations, complete a Functional Check Flight.

[Functional Check Flights \(on page 78\)](#)

How-To: Dock for X10 Software/Firmware Updates

This section explains how to complete a software or firmware update on the Dock for X10.

Update Via Skydio Cloud

Before updating, ensure the Drone is fully charged. For update downloading, connect to WiFi or a stable internet connection.

1. Ensure the Dock for X10 is powered ON.
2. Login to Skydio Cloud.
<https://cloud.skydio.com/entry/login>
3. Navigate to **Settings > Devices**.
4. Select the applicable Drone's **Device Page**.

If an update is available, it will be indicated next to the Dock's name.

5. Click **Update**.

To update the Drone, follow the on-screen prompts.

Important:

Do NOT power off the Dock or exit the application while the update is in progress.

During the update, the lights (LEDs) on the Dock will indicate update status.

Important:

After download and installation, the Dock will automatically reboot.

6. Upon reboot, do the following:
 - a. Re-connect to the Dock in Skydio Cloud.
 - b. verify the update is correct.
7. After all Parts have been updated and before returning the flight system to normal operations, complete a Functional Check Flight.
[Functional Check Flights \(on page 78\)](#)

Functional Check Flights

Upon completion of each maintenance interval, it is recommended that a Functional Check Flight (FCF) is performed by the Remote Pilot in Control (RPIC) or Field Services Technician.

Important:

Any individual performing functional check flights must be qualified per FAA requirements, including a Remote Pilot Certificate for Part 107 operation.

Maintenance intervals for the flight system include:

- System installation
- Scheduled maintenance
- Repairs
- Replacement of system Parts
- Software updates

It is recommended that FCFs be documented in the Maintenance Logbook to include:

- Date of the FCF
- Device IDs for the Dock for X10 and Skydio X10 Drone
- RPIC who performed the FCF
- Duration of the FCF
- Results of the FCF (including any items that require post-flight action)

Note:

A sample Maintenance and Functional Check Flight log is included in this section. Standard operating procedures related to Functional Check Flights are the responsibility of the Owner/Operator of the flight system to develop, execute and document.

For a printable Functional Check Flight Log, see: [Maintenance and Functional Check Flight Log Template \(on page 82\)](#)

Maintenance Log

Record Name	Equipment ID	Description of Activity or Update	Date of Activity or Update Performed	Name of Person Performing Activity or Update
X10 Update	X10 - FA1234567	Replaced all 3 propellers	5/15/25	John Doe
Signature: John Doe 5/15/25				

Functional Check Flight Log

Record Name	Equipment ID	FCF Completed?	Date of FCF	FCF Pilot	FCF Duration (mins)	FCF Result
X10 Update	X10 - FA1234567	Completed	5/15/25	John Doe	10	Successful!
Signature: John Doe 5/15/25						

How-To: Functional Check Flight

This section contains information about Functional Check Flights.

Prior to conducting remote operations, the Remote Pilot in Control (RPIC) must complete a series of preflight checks to ensure the Flight System is airworthy, the environment is safe, and the system configuration reflects operational requirements.

The purpose of the Functional Check Flight (FCF) is to do the following:

- Verify the Drone is functioning properly.
- Ensure the Drone is in a condition for safe operation.
- Familiarize the RPIC with any new features.

Functional Check Flight Process

To verify the aircraft is fully functional and ready to be deployed for future operations, the RPIC should conduct a FCF keeping the aircraft over a safe area.

Verify the following function properly:

Important:

If any unexpected flight behavior occurs during an FCF, immediately return and land.

- Launch
- Manual flight maneuvers along each axis:
 - Strafe left/right
 - Ascend/descend
 - Fly forward/backwards
- Test Sensor Package during Drone yaw and angle
- Test features that are routinely used
- Test for any new features
- Verify the drone returns and lands properly

Before starting a FCF, do the following:

1. Inspect environmental conditions using the External Dock Cameras (Flight System Page)

Note:

Refer to the Skydio Dock for X10 Operator Manual for detailed Preflight Inspection information.

2. To help identify potential safety issues which may interfere with launch or mission execution, use the External Dock Cameras to remotely inspect the following conditions:
 - Launch area
 - Sky conditions
 - Visibility
 - Surrounding environment

Tip:

The list of External Dock Cameras is available on the **Flight System Page** of the selected Dock.

Use the External Cameras to do the following:

- Verify the Dock launch/land area is free from obstruction
- Check for any people in the launch/land area so they can be notified and cleared of the area prior to launch
- Verify Safe Landing points are free from obstruction and people (if viewable from your External Dock Camera)
- Inspect general visibility and for low cloud ceilings

Important:

Visibility must be at least 3 statute miles (4.8 km) as seen from the control station. The RPIC must remain at least 400 feet (121.9 m) below any cloud and at least 2,000 feet (609.6 m) horizontally from it.

Maintenance and Functional Check Flight Log Template

The following are examples of a Maintenance Logs and Functional Check Flight Log.

Maintenance Log Template

Record Name	Equipment ID	Description of Activity or Update	Date of Activity or Update Performed	Name of Person Performing Activity or Update
Signature:				
Signature:				
Signature:				
Signature:				
Signature:				
Signature:				
Signature:				
Signature:				
Signature:				
Signature:				
Signature:				

Functional Check Flight Log Template

Record Name	Equipment ID	FCF Completed?	Date of FCF	FCF Pilot	FCF Duration (mins)	FCF Result
Signature:						
Signature:						
Signature:						
Signature:						
Signature:						

Emergency Stop and Lockout/Tagout

This section contains information about Emergency Stop (E-Stop) and Lockout/Tagout.

E-Stop Information

DANGER:

Motorized Dock for X10 moving parts. Moving parts may close or move unexpectedly. Pinch points will cause serious injury or death. Ensure the work area is clear of unnecessary personnel. Maintain a 7.0 ft (2.1 m) distance from all moving mechanisms. Obey all labels and warnings on the Dock. Follow local/site specific lockout/tagout procedures for de-energizing the Dock.

The Dock for X10 Flight System is equipped with 2x red E-Stop buttons located on the exterior sides of the Base.

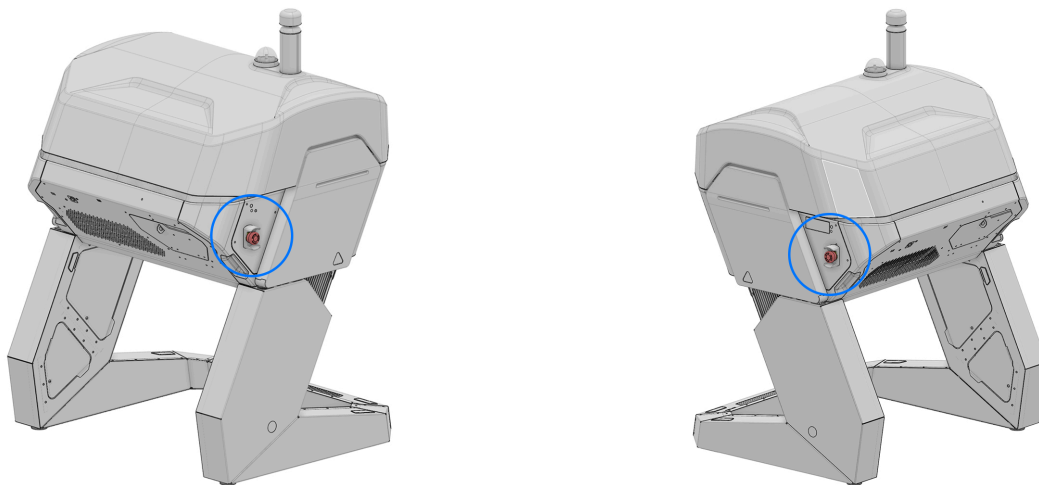

Engaging the E-Stop will cut power to high energy Parts like motors, chargers, and temperature controls. However, low power compute Parts will remain energized.

Important:

Only use the E-Stop in situations where it is necessary to halt all Dock activity, such as:

- A visible safety hazard (ex. smoke, overheating, or physical damage)
- Immediate risk to nearby personnel or property
- Maintenance or power isolation requirements

How-To: Engage E-Stop

To engage E-Stop, firmly push one or both of the red E-Stop buttons inward.

The Dock will shut down immediately. If a Drone is actively flying when power is shut off, the Drone will follow Lost Connection behaviors.

Note:

If the E-Stop is activated while the Roof is opening or closing, power will be lost and the Roof Motor will not operate. The Roof will fall gently to the fully open or fully closed position. The Roof may be moved manually while in this state.

CAUTION:

Risk of damage to Anemometer or Rain Sensor during roof operation. Potential damage to the Anemometer or Rain Sensor. When manually opening or closing the roof of the Dock, do not grab the Roof by the Anemometer or Rain sensor.

Lockout/Tagout (LOTO)

Before completing maintenance or service on the Dock for X10, ensure all energy sources connected to the Dock for X10 are safely isolated and cannot be unexpectedly energized by following Lockout/Tagout (LOTO) procedures.

DANGER:

Electrical hazard. Exposure to energized components can result in serious injury or death. Follow local/site specific lockout/tagout procedures for de-energizing the Dock and removing electrical hazards. Ensure the work area is clear of unnecessary personnel. If necessary, restrict access to the area.

Before performing service on the unit, do the following:

- Engage the Dock E-Stop button.
- Turn the Dock OFF.
- Disconnect the Dock from the AC power supply.
- Disconnect all external data and power cables from the Dock.
- Complete required lockout/tagout procedures per site requirements.

Important:

If field service is required, a Skydio-certified technician will shut off power and lock out/tagout the flight system.

Maintenance Logs

Logging Maintenance Intervals

At the conclusion of each maintenance interval, it is advised that all information related to any repair, replacement, update, or modification be tracked in a Maintenance log. Maintenance log information should include the following information:

- Date the maintenance was performed
- Name and organization of the individuals performing the maintenance action
- Description of the maintenance actions performed, including:
 - Dock-based field service
 - Regular Drone maintenance
 - Software updates
- Results of the Functional Check Flight (FCF)

Note:

FCF information can be logged separately. See: [Functional Check Flights \(on page 78\)](#).

Maintenance Log Template

For Maintenance and Functional Check Flight Log Templates, see: [Maintenance and Functional Check Flight Log Template \(on page 82\)](#)

Tip:

In addition to the Maintenance Log template, it is recommended that the Notes section of a Device Page in Skydio Cloud is utilized. This section is useful for high-level snapshots of recent maintenance activity.

Skydio Support

Skydio Support is available seven days a week.

The general response time for a Support inquiry is 24-48 business hours, however, most urgent requests are answered within 1-2 business hours.

Skydio Support Hours

Support business hours and available channels may expand over time. Please check <https://skydio.com/myrequests> for updates to hours of operation and service channels.

To contact Skydio Support, see: [How-To: Contact Skydio Support \(on page 87\)](#).

Day	Time
Monday - Friday	8 am - 2 am EST
Saturday - Sunday	8 am - 6 pm EST

How-To: Contact Skydio Support

This section explains how to contact Skydio Support.

For Support needs related to General Care or Scheduled Maintenance, do the following:

- Email Skydio at support@skydio.com.
- Create a case via <https://skydio.com/myrequests>.

For urgent troubleshooting or other requests where real-time assistance is needed:

- Call Skydio Support: **855-463-5902**
- Use the **Contact Skydio Support** button within a Device Page to reach out via email or phone.

To view all Support services rendered for a customer account:

- [Customer Portal](#)
- <https://skydio.com/myrequests>

Note:

To request access, email support@skydio.com.

How-To: Uploading Support Logs

When contacting Skydio Support for troubleshooting help, there may be requests to upload Support Logs. Support Logs assist with diagnosing issues.

There are two different types of logs to upload:

- **Flight Support Logs** contain data from a specific flight. For issues experienced during flight such as a "Failed return to the Dock", upload a Flight Support Log.
- **Device Support Logs** include debugging data from outside of a flight, such as failures to launch or device-specific issues (ex. the Dock camera is not working). Device Logs help address issues that occur before or after flight.

Note:

Customers cannot download or analyze flight logs for troubleshooting purposes. All tooling used to interpret flight logs is proprietary to Skydio. If flight data needs to be reviewed, the Skydio Support team will conduct the analysis and provide a summary or root cause assessment as needed. If video from the primary or navigation cameras is required for review, Skydio will first obtain permission.

How to upload a Flight Support Log

1. Navigate to the **Flight Systems Page**.
Fleet > Select the applicable device.

2. Scroll to **Flight History**.

Note:

Located under the Dock camera.

3. Click the three dots.

4. Select **Upload Skydio Flight Support Log**.

5. Select **Release to Skydio**.

For organizations that follow Criminal Justice Information Services (CJIS) protocols, to release certain flight, media, or data files to Skydio, optionally mark them as **Non-CJI**. This helps to ensure Skydio Support can assist without compromising restricted media.

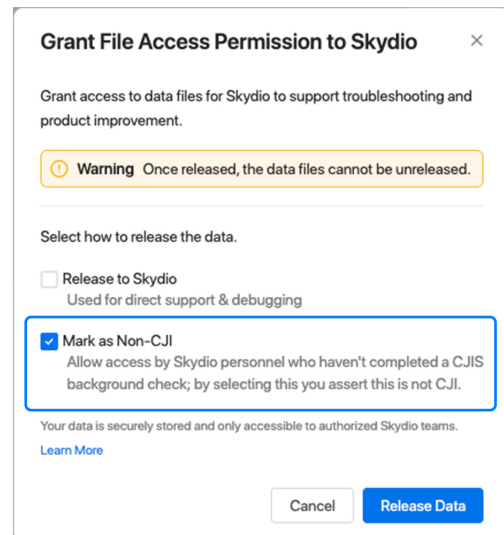
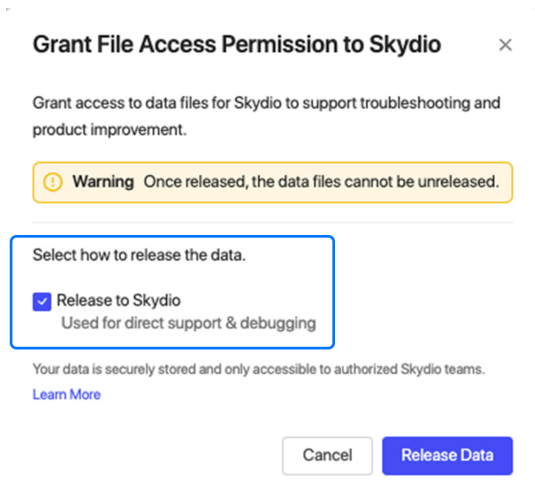

6. Click **Release Data**.

How to upload a Device Support Log

1. Open an applicable **Device Page**.
Settings > Devices or select a device from the Fleet page and the gear icon.
2. From the **Device Page**, select the **Settings** tab.

Note:

Located under the name of the Device.

3. Within the **Tools** section, click the **Upload** button next to **Upload Skydio Device Support Log**.

Terms and Conditions

Safe Operation

Before operating a Skydio Dock for X10 Flight System, review the Getting Started information including the Skydio Dock for X10 Flight System Operator Manual available at: www.skydio.com/manuals and the Skydio Safety and Operating Guide available at: www.skydio.com/safety .

Retain all documentation for future reference.

Battery

Handle Batteries with extreme care. For additional information, refer to the Skydio X10 Operator Manual and Skydio Safety and Operating Guide.

DANGER:

Risk of fire, explosion, serious injury, or death. Failure to follow battery safety warnings and handling guidelines can cause fire, explosion, or severe burns, resulting in serious injury or death, and may damage the drone, Dock, or surrounding property. Incorrect battery replacement can cause fire or explosion, resulting in serious injury, death, or property damage.

WARNING:

Risk of fire or equipment damage. Use only batteries designed specifically for use with Skydio equipment. Do not install or operate the system with incompatible cells or batteries.

WARNING:

Risk of fire, explosion, or injury from damaged or improperly handled batteries. If a battery shows signs of damage, such as substantial gouging or cracking of the plastic housing, place it in a non-flammable enclosure away from people and contact a local hazardous waste recycling agency for safe handling and disposal. Do not dismantle, open, or shred batteries. Do not dispose of batteries in regular garbage or recycling bins. Lithium polymer batteries must be disposed of only at certified electronic waste or battery recycling facilities. Never include batteries in burned waste. Lithium polymer batteries contain flammable materials that can cause explosive fires when overheated and may re-ignite due to thermal runaway. Do not store batteries in metal containers without appropriate insulation. Store damaged and undamaged batteries separately in temperature-controlled, non-conductive containers.

Skydio One (1) Year Limited Warranty

Skydio warrants the included hardware product against defects in materials and workmanship in hardware under normal use in accordance with published guidelines including but not limited to the Terms of Use, Operator Manual and the Skydio Safety and Operating Guide for one year from the date of delivery (the "Limited Warranty"). The Limited Warranty does not warrant against normal wear and tear or damage caused by accident or abuse and is not applicable to any software provided with the hardware product. The Limited Warranty is subject to the full terms and detailed information about how to obtain service available at www.skydio.com/legal/limited-warranty . If a valid claim is submitted under this Limited Warranty, Skydio will either repair, replace, or refund a hardware product at its sole discretion. The customer may be required to furnish proof of purchase details when making a claim under this Limited Warranty.

Skydio Care for Drones Only

Skydio offers Skydio Care for its Drones only as a subscription service at an additional cost that provides protection from collisions, water damage, or lost Drones which are not covered under the Limited Warranty. Skydio Care can be purchased as a one (1) year plan co-extensive with the Limited Warranty, or as a three (3) year plan, which includes a two (2) year extension to the one (1) year term of the Limited Warranty.

Skydio Care is subject to the full terms and detailed information about how to obtain service available at <https://www.skydio.com/legal/skydio-care-terms-of-service>. If a valid claim is submitted under Skydio Care, customers may be eligible to purchase discounted Drone replacements for otherwise uncovered damage or losses. The Skydio Care benefits are in addition to the rights provided under the Limited Warranty.

For the Skydio Dock for X10, maintenance plans may be made available. Please reach out to a Skydio sales representative for additional details.

California Prop 65 Warnings

Skydio X10 uses lithium-ion batteries. Exposure to lithium-ion, containing cobalt lithium nickel oxide, and nickel, is known to the State of California to cause cancer and birth defects, or other reproductive harm. For more information visit: www.P65Warnings.ca.gov.

Skydio X10 VT300-Z, VT300-L, and V100-L sensor packages contain chemicals including nickel, which are known to the State of California to cause cancer and birth defects, or other reproductive harm. For more information visit: www.P65Warnings.ca.gov.

FCC Compliance Statement

Any changes or modifications to this equipment not expressly approved by Skydio will void the user's authorization to operate this equipment.

This equipment has been tested and found to comply with the limits for a Class A digital device, pursuant to Part 15 of the FCC Rules. These limits are designed to provide reasonable protection against harmful interference in a residential installation. This equipment generates, uses and can radiate radio frequency energy and, if not installed and used in accordance with the instructions, may cause harmful interference to radio communications. However, there is no guarantee that interference will not occur in a particular installation. If this equipment does cause harmful interference to radio or television reception, which can be determined by turning the equipment off and on, the user is encouraged to try to correct the interference by one of the following measures:

- Reorient or relocate the receiving antenna.
- Increase the separation between the equipment and receiver.
- Connect the equipment into an outlet on a circuit different from that to which the receiver is connected.
- Consult the dealer or an experienced radio/TV technician for help.

This device complies with Part 15 of the FCC Rules. Operation is subject to the following two conditions:

- This device may not cause harmful interference.
- This device must accept any interference received, including interference that may cause undesired operation.

This equipment complies with FCC radiation exposure limits set forth for an uncontrolled environment. The distance between user and products should be no less than 20cm. The end user must follow the specific operating instruction for satisfying RF exposure compliance. This transmitter must not be co-located or operating in conjunction with any other antenna or transmitter.

CANADA (ISED)

The installer of this radio equipment must ensure that the antenna is located or pointed such that it does not emit RF field in excess of Health Canada limits for the general population; consult Safety Code 6, obtainable from Health Canada's website <https://www.canada.ca/en/services/health/health-risks-safety.html>.

This device contains license-exempt transmitter(s)/receiver(s) that comply with Innovation, Science and Economic Development Canada's license-exempt RSS(s). Operation is subject to the following two conditions:

- This device may not cause interference.
- This device must accept any interference, including interference that may cause undesired operation of the device.

L'installateur de cet équipement radio doit s'assurer que l'antenne est située ou pointée de manière à ne pas émettre de champ RF au-delà des limites données par Santé Canada pour la population générale; consultez le Code de sécurité 6, disponible sur le site Web de Santé Canada www.hc-sc.gc.ca/rpb.

L'émetteur exempt de licence contenu dans le présent appareil est conforme aux CNR d'Innovation, Sciences et Développement économique Canada applicables aux appareils radio exempts de licence. L'exploitation est autorisée aux deux conditions suivantes:

- L'appareil ne doit pas produire de brouillage;
- L'appareil doit accepter tout brouillage radioélectrique subi, même si le brouillage est susceptible d'en compromettre le fonctionnement

FAA Remote ID Compliance Statement

Skydio Drones sold in the United States are Standard Remote ID-compliant. Unless specifically exempt, this product complies with 14 CFR Part 89 regulations on Remote Identification per RID-ASTM-F3586-22-NOA-23-01 (ASTM F3411-22a-RID-B and ASTM F3586-22 with corrections).

The Skydio X10 DOC is RID000000750-11.

See DOC list here: <https://uasdoc.faa.gov/listDocs>.

Software License

The Skydio Software End-User License Agreement available at www.skydio.com/legal/eula governs the use of any Skydio software that is preinstalled, downloaded, installed, or otherwise provided in connection with any included hardware.

Additional Resources

For all the latest information about Skydio and our products visit: www.skydio.com.

For Skydio legal information and product terms of use visit: www.skydio.com/legal.

Skydio products are protected by patents and trademarks, registered in the United States and other countries. For Skydio intellectual property information visit: www.skydio.com/legal/ip.

© 2026 Skydio, Inc. All rights reserved. Skydio and the Skydio logo are trademarks of Skydio, Inc., registered in the United States and other countries.

Revision History

Revision	Description	Date
1	Initial Release	March 27, 2026