

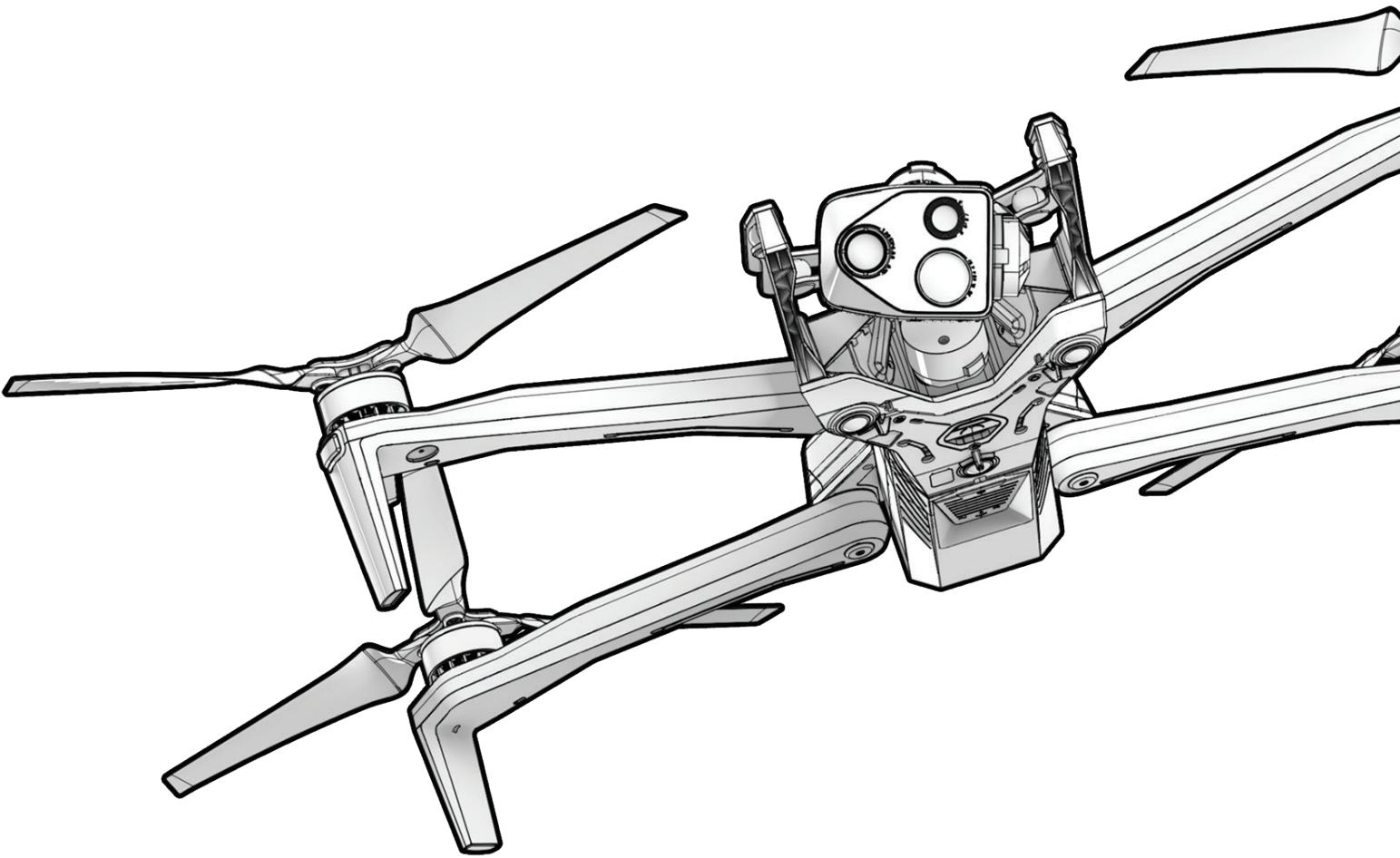

# Skydio X10

## Maintenance Manual





**WARNING:** Please read all documentation provided with your Skydio X10, including but not limited to the X10 Safety Guidelines in the Safety and Operating Guide: [www.skydio.com/safety](http://www.skydio.com/safety). Failure to follow any instructions or recommendations in our documentation may void the Skydio Limited Warranty.



**NOTE:** Skydio is not responsible for any loss, retention, or recovery of data resulting from the execution or non-execution of this Secure Data Erasure & Factory Reset procedure. The operator is solely responsible for ensuring that all required backups are completed and that each step of the checklist is properly performed and verified. Failure to follow the full procedure may result in residual data remaining on the aircraft, controller, or removable media. For more information, visit: [skydio.com/manuals](http://skydio.com/manuals)

# Revision History

Revision	Software Version and Description	Date
1	Initial release of the Skydio X10 Maintenance Manual, consolidating maintenance guidance previously distributed across the Operator Manual and Support documentation.	March 23, 2026
2	Updated Sensor Package Isolator maintenance guidance.	April 20, 2026

## Scope

This manual is designed to provide users with maintenance procedures and schedules to ensure optimal flight behavior. A lifecycle table to record and track flight hours is included. Read the Operator Manual for detailed information about flying your Skydio X10.

Sections divide the manual into major categories of information:

- **Equipment**
- **Fleet Management**
- **Maintenance**
- **Inspection**
- **Schedule**
- **Legal**



# Flight System Overview

This section covers

---

Skydio X10 Starter Kit

---

Skydio X10 Starter Case Layout

---

Skydio X10 Hardware

---

Skydio X10 Controller Hardware

---

Updating the X10 Controller

---

Updating Skydio X10

---

Specifications

---

# Skydio X10 Starter Kit

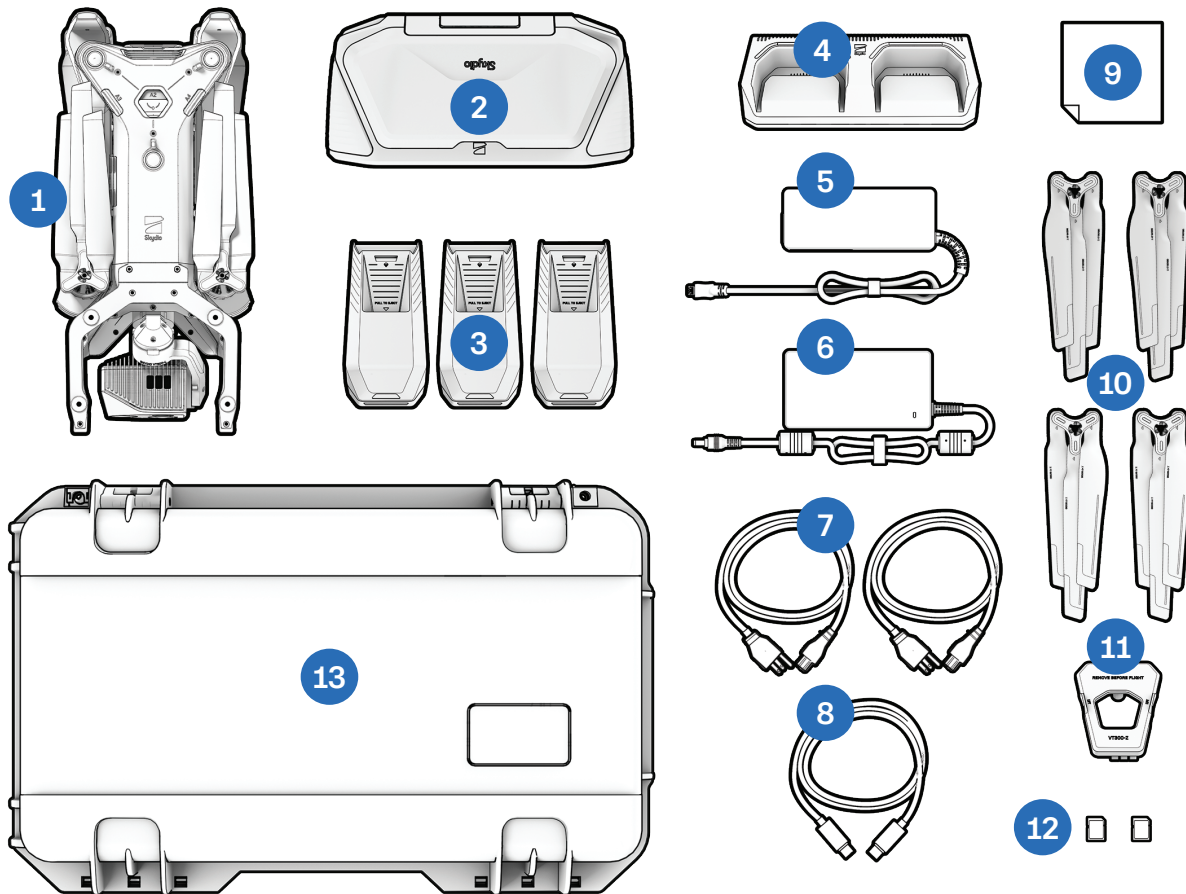

1. Skydio X10 and sensor package
2. Skydio X10 Controller with chosen Skydio Connect option
3. Batteries (3)
4. Skydio X10 Dual Charger
5. 100 W power supply (USB-C)
6. 230 W fast power supply (barrel jack)
7. Power cables (2)
8. USB-C to USB-C pairing cable
9. Microfiber cleaning cloth
10. Spare propeller sets (4)
11. Gimbal Stabilizer Clip
12. 256 GB microSD cards, pre-installed (2)
13. Starter Case (hard shell)

*Also included in some international shipments: USB-C to A adapter cable, neck strap, LTE USB adapter, Ethernet adapter*



*Scan for more information about the kits available for purchase.*

# Skydio X10 Starter Case Layout

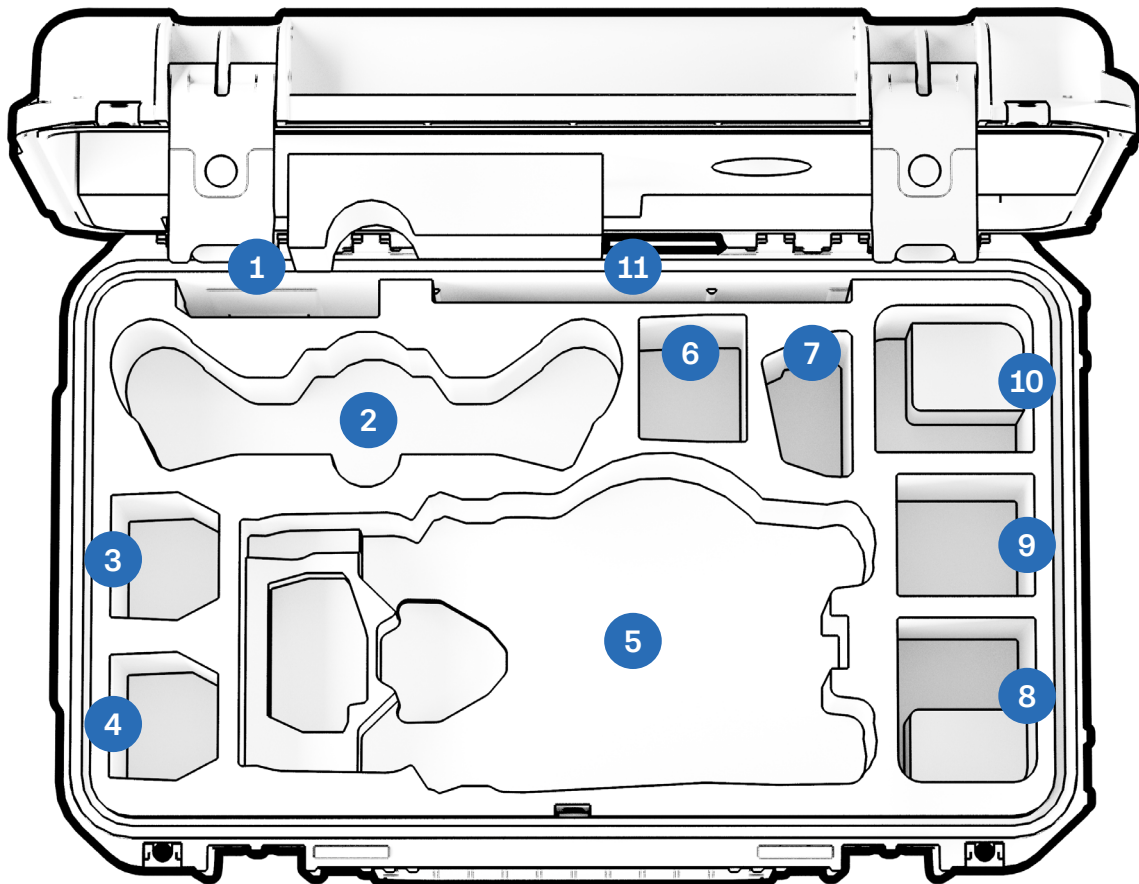

- |                                                 |                                                                          |
|-------------------------------------------------|--------------------------------------------------------------------------|
| 1. Propellers                                   | 8. Flex space: 100W Power Supply or Attachment (battery not recommended) |
| 2. X10 Controller                               | 9. Flex space: 100W Power Supply or Attachment (battery not recommended) |
| 3. X10 Battery                                  | 10. Flex Space: 230W Power Supply or Attachment                          |
| 4. X10 Battery                                  | 11. Quick Start Guide and other documents                                |
| 5. Skydio X10 Drone                             |                                                                          |
| 6. Flex space: 100W Power Supply or X10 Battery |                                                                          |
| 7. X10 Dual Charger                             |                                                                          |



**NOTE:** If you purchased a Starter Case prior to March 2026 and later upgrade to the VT300-Z REV2 sensor package, the REV2 will not fit in your existing case. Skydio X10 Starter Cases purchased after March 2026 are compatible with the VT300-Z REV2.

# Skydio X10 Hardware

1. Chassis
2. Arm (4)
3. Sensor package
4. Sensor package frame
5. Log and Media card slots (2)
6. Top navigation cameras (3)
7. Top attachment bay (A2)
8. Side attachment bay (A3, A4)
9. Bottom navigation cameras (3)
10. Bottom attachment bay (A1)
11. Time of flight sensor

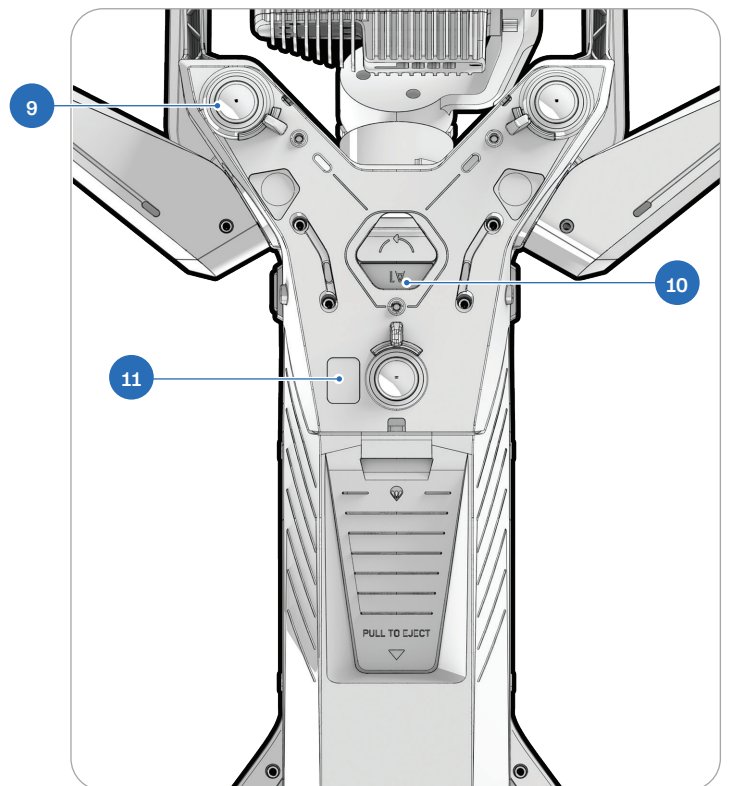
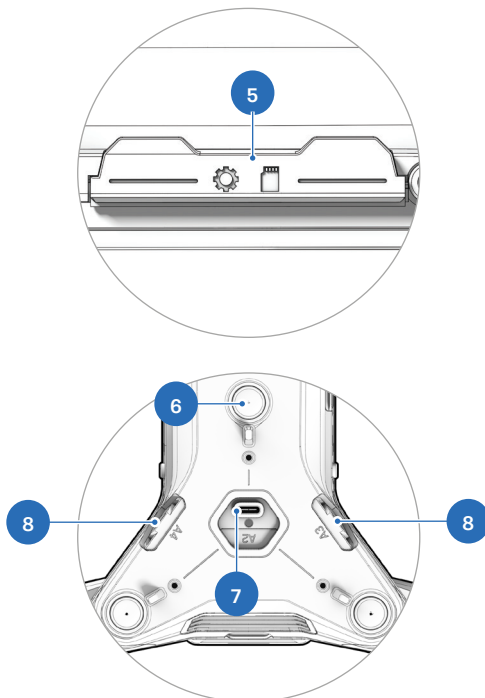
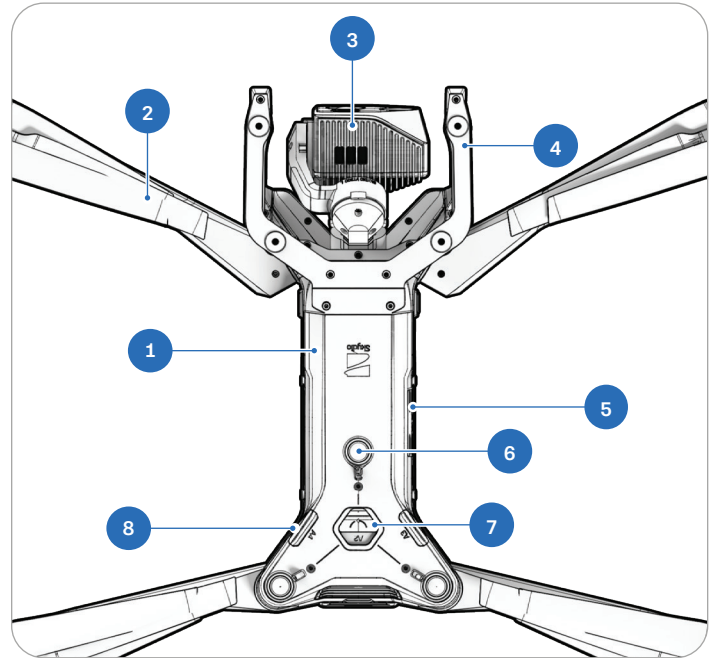

# Flight System Overview

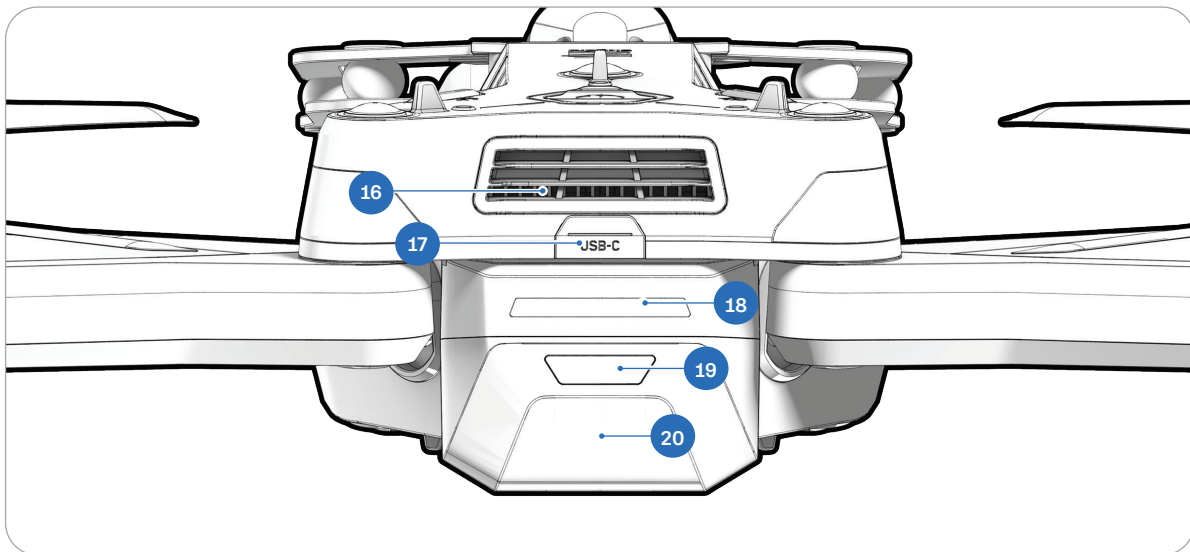
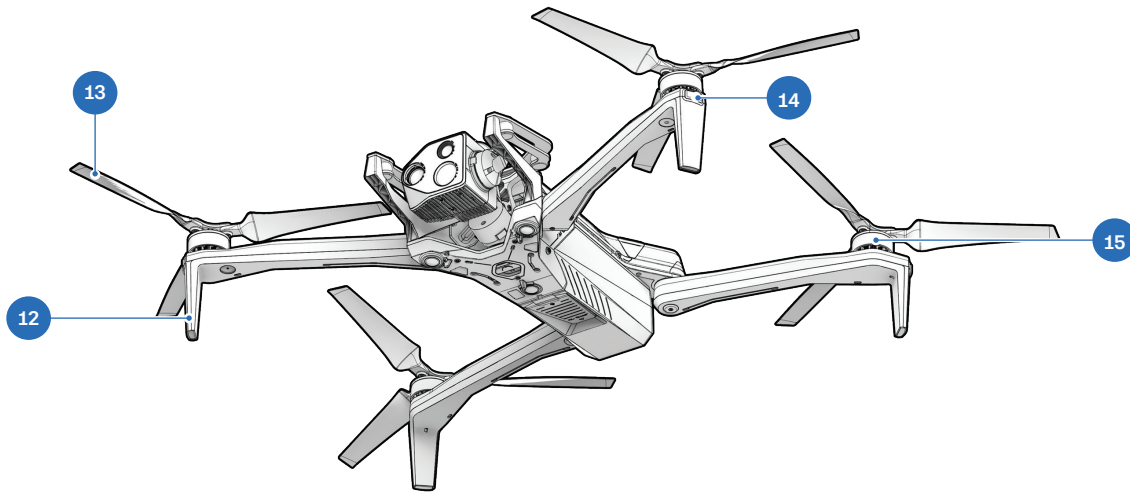

- 12. Landing feet/antennas
- 13. Propeller blades
- 14. RGB/strobe lights
- 15. Propeller motors
- 16. Cooling fan/outlet
- 17. USB-C charge port
- 18. Battery lights
- 19. Power button
- 20. Battery



*Scan for more information about the sensor packages available for purchase.*

# Skydio X10 Controller Hardware

1. Left joystick
2. Menu/Back button
3. C1 button<sup>1</sup>
4. C2 button<sup>1</sup>
5. C3 button<sup>1</sup>
6. Power button
7. Launch/Return/Land button
8. Pause button
9. Directional pad (D-pad)
10. Right joystick
11. Controller cover/antennas
12. R1 button (Shutter)
13. Right wheel
14. HDMI port
15. USB-C charge port
16. L1 button (Boost)
17. Left wheel<sup>1</sup>
18. R2 button<sup>1</sup>
19. Cooling fan
20. Neck strap<sup>2</sup> and tripod mount
21. L2 button<sup>1</sup>

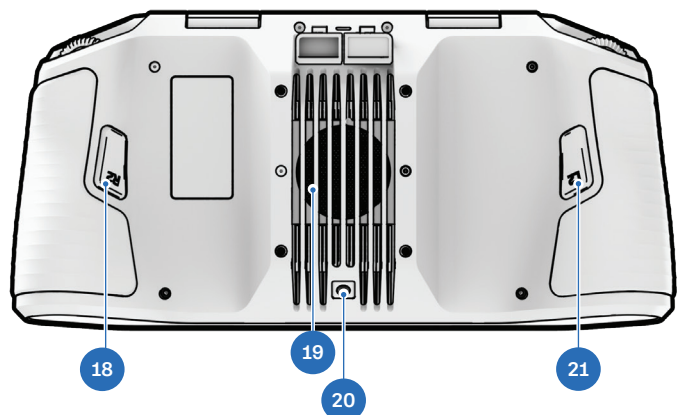
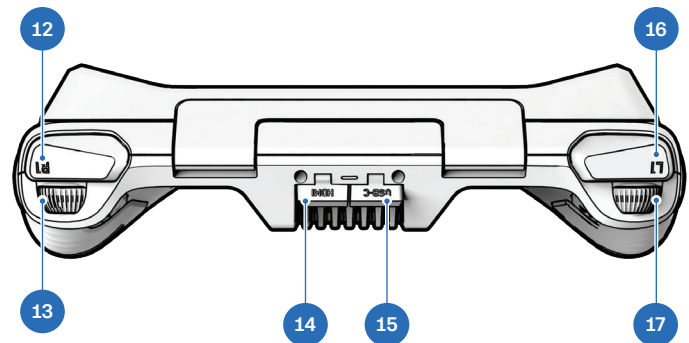
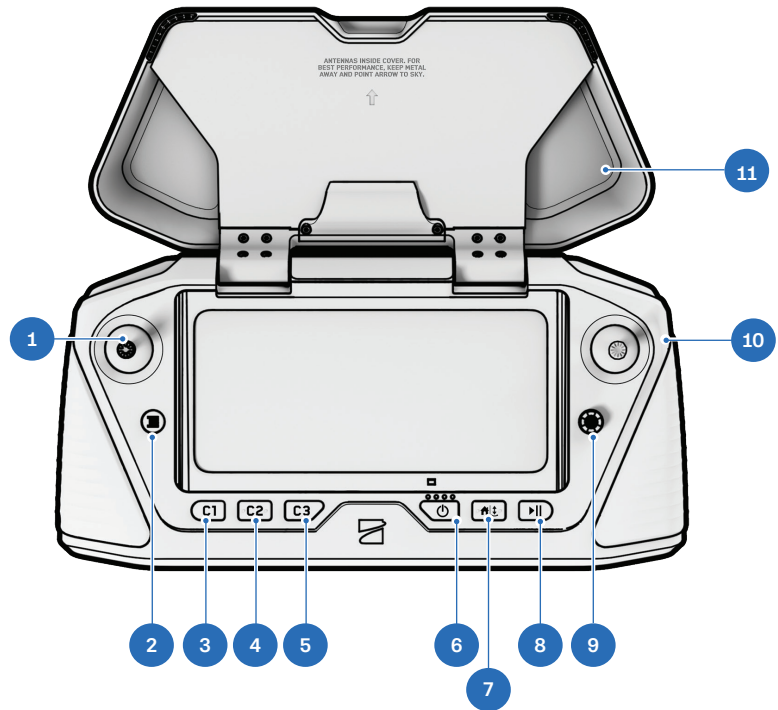

<sup>1</sup>Customizable

<sup>2</sup>Neck strap sold separately

# Updating the Skydio X10 Controller



**NOTE:** Check for available updates before flying. You must update the Skydio X10 Controller first before updating Skydio X10.

## Step 1 - Power on the Skydio X10 Controller

Open the controller lid and hold the Power button for five seconds. The lights on the front of the controller will turn on and indicate the level of charge.

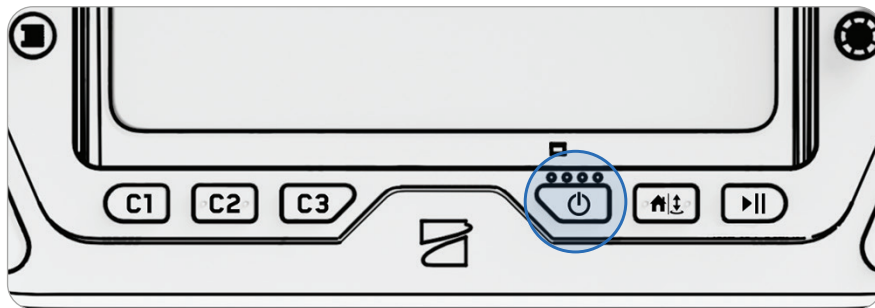

## Step 2 - Navigate to the Information menu

Located within Global Settings.

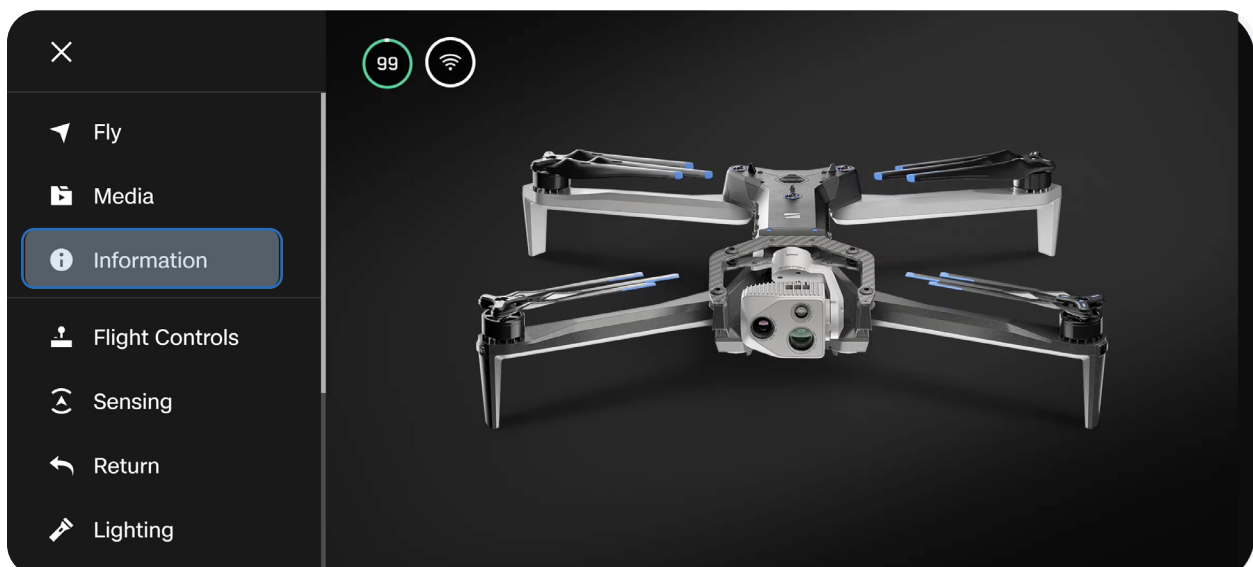

# Flight System Overview

---

## Step 3 - Select Controller Update under Settings

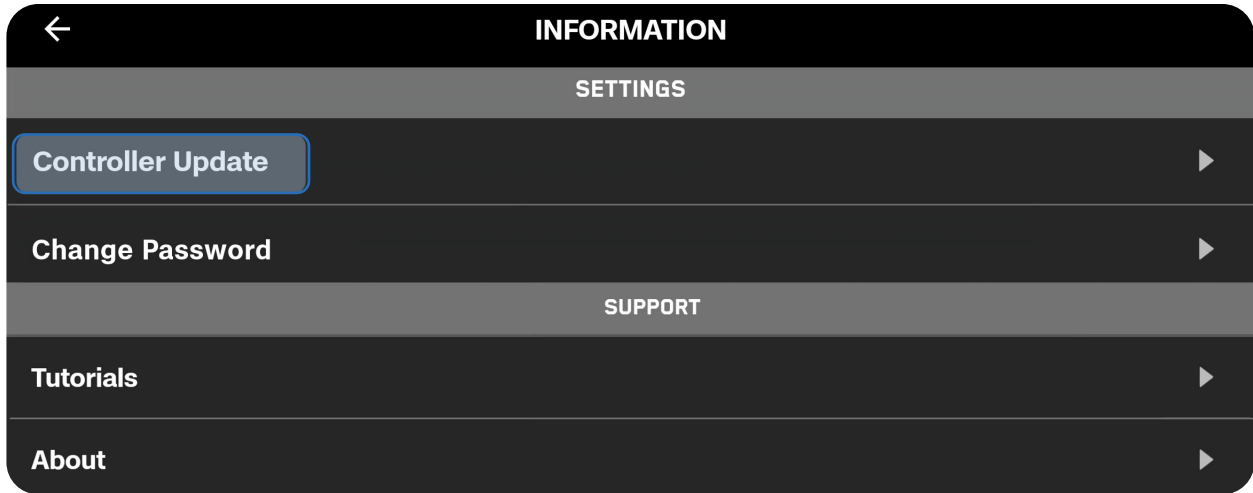

## Step 4 - Select Check for Update

## Step 5 - Select Update

Follow the on-screen prompts to update your controller.

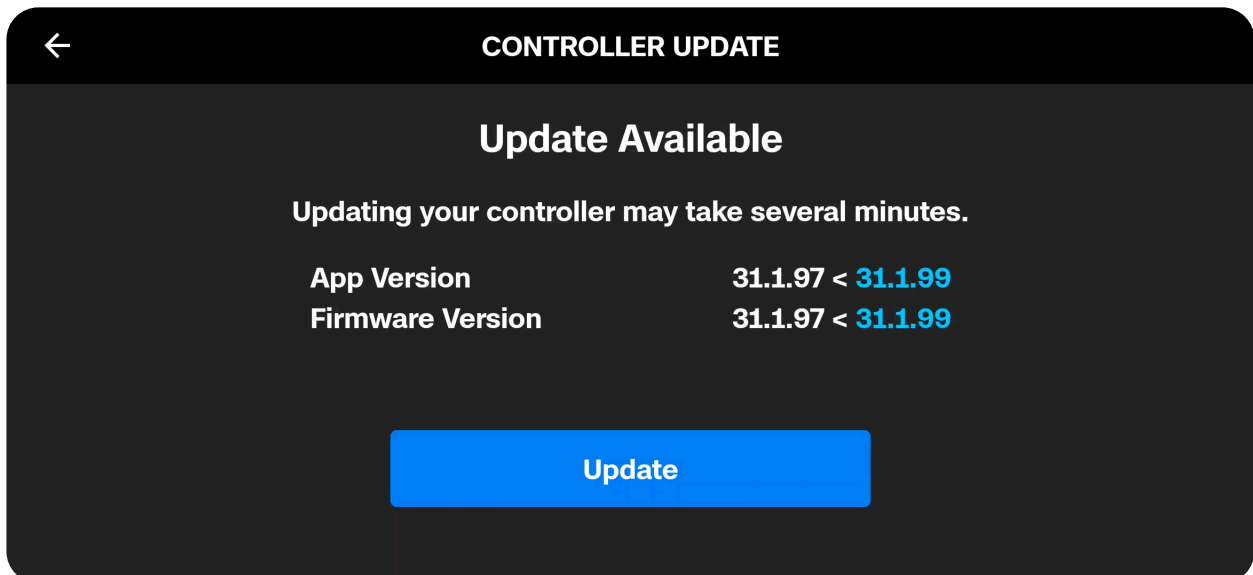

# Updating Skydio X10

Skydio will not force an update for your system, however, for optimal performance, we recommend that you keep your Skydio system up-to-date. If an update is available, you will see a red notification icon in the **Information** menu.

### Step 1 - Power on Skydio X10

Press and hold the Power button on the battery for three seconds.

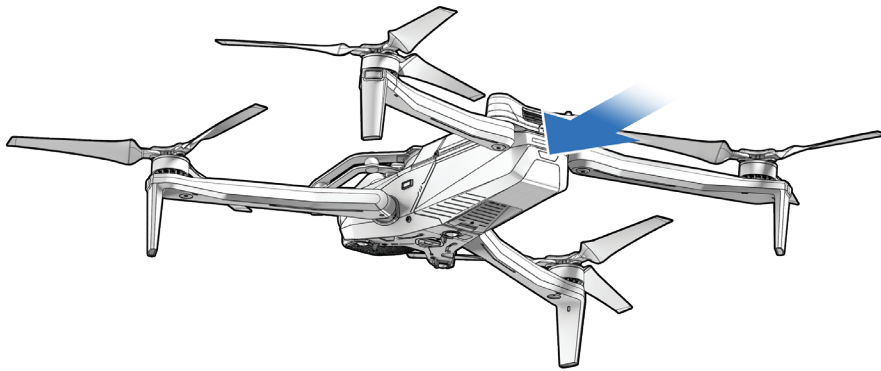

### Step 2 - Power on the Skydio X10 Controller

Open the controller lid and hold the Power button for five seconds. The lights on the front of the controller will turn on and indicate the level of charge.

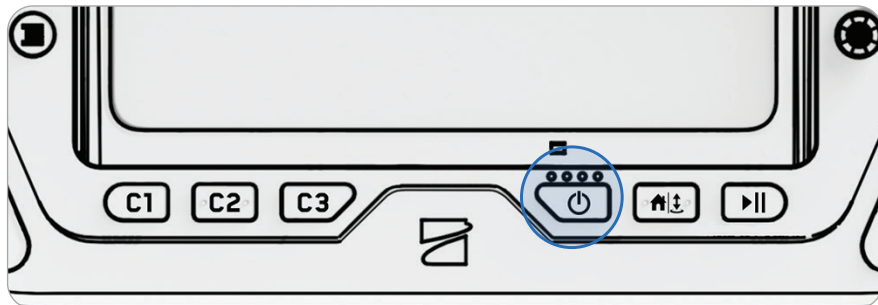

# Flight System Overview

## Step 3 - Navigate to the Information menu

Located within Global Settings.

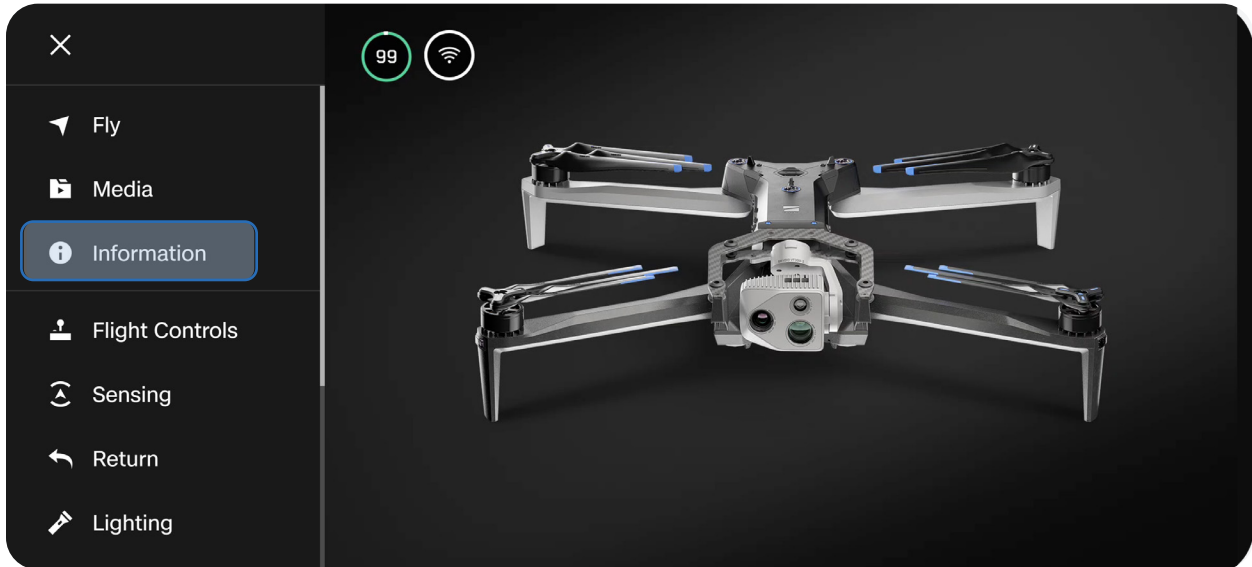

## Step 4 - Select your Skydio X10 under Devices

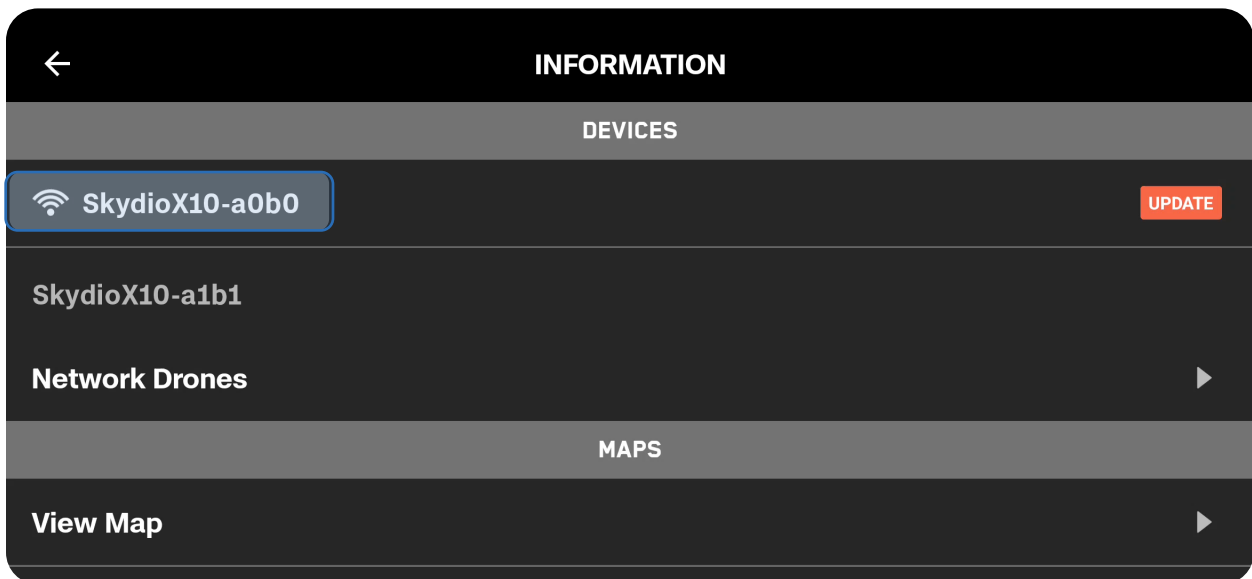

# Flight System Overview

---

## Step 5 - Select Update

Follow the on-screen prompts to update your drone.

Select **Check for Updates** anytime to look for available updates.

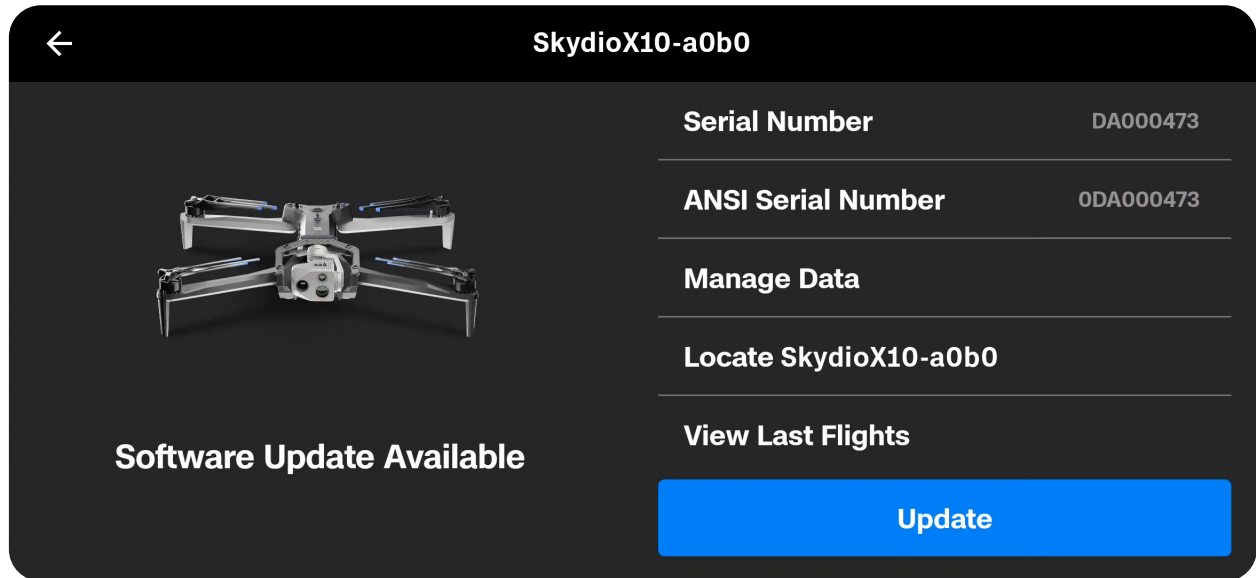

# Specifications

## X10 Drone

---

<b>Applicable Model Numbers</b>	SR47PI, SR47PV, SR47PCI, SR47PCV SR47PC9V
<b>Dimensions (unfolded, with propellers)</b>	31.1" x 25.6" x 5.7"
<b>Dimensions (folded, without battery)</b>	13.8" x 6.5" x 4.7"
<b>Weight (incl. batteries)</b>	Connect SL: 2.11 kg / 4.65 lbs Connect SL + 5G1: 2.14 kg / 4.72 lbs
<b>Max Launch Weight</b>	2.49 kg / 5.49 lbs
<b>Operation Frequency</b>	Connect SL: 2400-2483.5MHz, 5150-5850Mhz
<b>Transmitter Power (EIRP)</b>	Connect SL: 34.3dBmi (2.4GHZ) Connect SL: 33.7dBmi (5GHZ)
<b>Hovering Accuracy (windless or breezy)</b>	VIO: +/- 10cm
<b>Max Angular Velocity</b>	GNSS: +/- 1m
<b>Max Tilt Angle</b>	Yaw: 100 deg/s Roll / Pitch: 225 deg/s 40 degrees
<b>Max Ascent/Descent Speed</b>	Ascent: 6 m/s / 13.4mph Descent: 4 m/s / 9.0mph
<b>Max Non-Vertical Descent Speed</b>	6 m/s / 13.4mph
<b>Max Horizontal Speed (at sea level)</b>	20 m/s / 45mph
<b>Max Horizontal Speed with Obstacle Avoidance</b>	16 m/s / 36mph
<b>Max Service Ceiling Above Sea Level (without other payload)</b>	15,000 ft density altitude
<b>Max Gust Handling</b>	Under 12.8 m/s / 28 mph
<b>Max Hover Time</b>	35 minutes
<b>Max Flight Time<sup>1</sup></b>	40 minutes

## Flight System Overview

---

<b>Processors</b>	NVIDIA Jetson Orin SoC Qualcomm QRB5165 SoC
<b>Ingress Protection Rating</b>	IP55
<b>GNSS</b>	GPS + Galileo + GLONASS + BeiDou
<b>Operational Temperature Range</b>	-20C to +45C / -4F to 113F
<b>Wireless Range (no interference, line of sight operation)</b>	Connect SL: 12km / 7.5 miles
<b>Wireless Networking (media offload)</b>	Connect SL: WiFi6
<b>Obstacle Avoidance Coverage</b>	True 360°

<sup>1</sup>In optimal, controlled conditions; completely depleting a fully charged battery

## X10 Controller

---

<b>Controller Dimensions</b>	10" x 5" x 3"
<b>Dimensions</b>	10.5" x 5" x 3"
<b>Screen</b>	6.6" Dynamic AMOLED touchscreen 120Hz Adaptive Refresh Rate Resolution: 2340 x 1080 pixels Brightness: 1750 nits (outdoor peak) 392ppi
<b>Weight</b>	1135 grams
<b>Max Range</b>	Connect SL: 12km / 7.5 miles
<b>Operating Frequencies</b>	Connect SL: 2400-2483.5MHz, 5150-5850MHz
<b>Transmitter Power (EIRP)</b>	Connect SL: 34.7dBmi (2.4GHz) Connect SL: 35.9dBmi (5GHz)
<b>Ingress Protection Rating</b>	IP54
<b>Operating Time</b>	Approx. 5 hours
<b>Battery</b>	9600mAH
<b>GNSS</b>	GPS + Galileo + GLONASS + BeiDou
<b>Operational Temperature Range</b>	-20C to +45C / -4F to 113F
<b>Wired Outputs</b>	HDMI & USB-C
<b>Wireless Networking</b>	WiFi, Cellular LTE/5G 1
<b>Security</b>	NDA compliant AES-256 encrypted data link Encrypted internal disk storage Password protected Root of trust Trusted boot Secure update

---

### VT300-Z Sensor Package

---

Angular Vibration Range

---

User Controllable Range

---

Mechanical Range

---

### VT300-L and V100-L Sensor Package

---

Angular Vibration Range

---

User Controllable Range

---

Mechanical Range

---

Flashlight Illumination

---

### Telephoto Camera (VT300-Z only)

---

Sensor	1/2" 48MP CMOS
Diagonal Field of View	13°
Focal Length	35 mm (190 mm equivalent)
Aperture	f/2.2
Focus	hybrid PDAF, 5 m to ∞
Exposure Compensation	+/-3
Electronic Shutter Speed	1/30 to 1/8000
ISO Range	100 to 16000
Max Video Resolution	3840 x 2880
Max Photo Size	8000 x 6000

### Wide Camera (VT300-L and V100-L only)

---

Sensor	1" 50.3MP CMOS
Diagonal Field of View	93°
Focal Length	8 mm (20 mm equivalent)
Aperture	f/1.95
Focus	100% focus pixel, 1 m to ∞
Exposure Compensation	+/-3
Electronic Shutter Speed	1/30 to 1/8000
ISO Range	100 to 16000
Max Video Resolution	3840 x 2880
Max Photo Size	8192 x 6144

### Narrow Camera (VT300-Z, VT300-L, and V100-L)

---

Sensor	1/1.7" 64MP CMOS
Diagonal Field of View	50°
Focal Length	10 mm (46 mm equivalent)
Aperture	f/1.8
Focus	hybrid PDAF, 1 m to ∞
Exposure Compensation	+/-3
Electronic Shutter Speed	1/30 to 1/8000
ISO Range	100 to 16000
Max Video Resolution	3840 x 2880
Max Photo Size	9248 x 6944

---

### Thermal Camera (VT300-Z and VT300-L)

---

<b>Thermal Imager</b>	Flir Boson+ Uncooled VOx Microbolometer
<b>Diagonal Field of View</b>	41°
<b>Focal Length</b>	13.6 mm (60 mm equivalent)
<b>Aperture</b>	f/1.0
<b>Focus</b>	5 m to ∞
<b>Thermal Sensitivity</b>	<30mK NEDT
<b>Infrared Temperature Measurement Accuracy</b>	Larger of +- 5°C or 5%
<b>Image Processing</b>	Adreno 650 GPU accelerated ISP pipeline
<b>Max Video Resolution</b>	640 x 512
<b>Photo Size</b>	640 x 512
<b>Photo Format</b>	JPEG, RJPEG
<b>Pixel Pitch</b>	12 um
<b>Temperature Measurement Method</b>	Spot Meter, Region of Interest
<b>Temperature Measurement Range</b>	-40° to 150° C (-40° to 350° C low gain)
<b>Palette</b>	White hot Black hot Ironbow Rainbow

---

### Vision Systems / Navigation Cameras

---

<b>Configuration</b>	6x cameras in trinocular configuration top and bottom
<b>Sensor</b>	1/2.8" 32MP color CMOS
<b>Light Sensitivity</b>	Visible Light
<b>Aperture</b>	f/1.8
<b>Diagonal Field of View</b>	200°
<b>Obstacle Sensing Range</b>	20 meters
<b>Environment Coverage</b>	True 360°

---

### Flight Battery

---

<b>Capacity</b>	8419 mAh
<b>Voltage</b>	18.55 V
<b>Battery Type</b>	Rechargeable Lithium Ion Polymer
<b>Energy</b>	156.17 Wh
<b>Net Weight</b>	1.56 lbs +/- 0.003 lbs
<b>Operational Temperature Range</b>	-20C to 60C
<b>Storage Temperature Range</b>	-20C to +45C (storage less than 3 months)
<b>Charging Temperature Range</b>	5C to 45C
<b>Chemical System</b>	Lithium Ion Polymer

---

### Skydio Connect

---

<b>Operating Frequency</b>	Connect SL: 2400-2483.5MHz 5150-5850MHz Connect 5G: 600MHz-4400MHz
----------------------------	--------------------------------------------------------------------------

---

<b>Transmitter Power (EIRP)</b>	Connect SL: 34.7dBmi (2.4GHz) Connect SL: 35.9dBmi (5GHZ) Connect 5G: 20dBmi
---------------------------------	------------------------------------------------------------------------------------

---

<b>Antenna Configuration</b>	Connect SL: 2Tx, 4Rx
------------------------------	----------------------

---

### System Security

---

<b>Wireless Encryption</b>	Connect SL: AES-256
----------------------------	---------------------

---

<b>NDAA Compliance</b>	NDAA Compliant
------------------------	----------------

---

<b>Root of Trust</b>	HSM protected keys
----------------------	--------------------

---

<b>System Integrity</b>	Secure boot
-------------------------	-------------

---

<b>Secure Update</b>	AES-256 encrypted, signed, & verified
----------------------	---------------------------------------

---

<b>Internal Disk Storage</b>	Encrypted
------------------------------	-----------

---

<b>SD Cards</b>	Unencrypted
-----------------	-------------

---

<b>Pairing</b>	Secure wired pairing
----------------	----------------------

---

### X10 Dual Charger and Power Supplies

---

<b>Dimensions</b>	180 x 75 x 48mm
<b>Weight (w/o Battery)</b>	0.73 lbs
<b>Charge Time 230W</b>	1 hour (0-100%)
<b>Charge Time 100W</b>	1 hour 45 minutes (0-100%)
<b>Weatherproofing</b>	No ingress protection
<b>Power input (100W USB-C)</b>	5VDC, 3A / 20VDC, 5A (USB PD)
<b>Power input (230W DC Barrel)</b>	20VDC, 11.5A

---



# Fleet Management

This section covers

---

Data Storage

---

Passwords

---

---

---

---

---

---

---

---

---

---

# Data Storage

There are two 256 GB UHS Speed Class 3 (or faster) microSD cards one for storing media and one for recording flight logs. Each card will occasionally need to be cleared of data and reformatted. Reformatting the cards will delete the stored data, ensure that any data is safely transferred.

**Step 1 - Select the Global Settings menu, Information, and drone name under Devices**

**Step 2 - Select Manage Data and either**

- Format Media Card or
- Format Logs Card

**Step 3 - Select Delete when the warning message displays**

- Select OK in the confirmation message

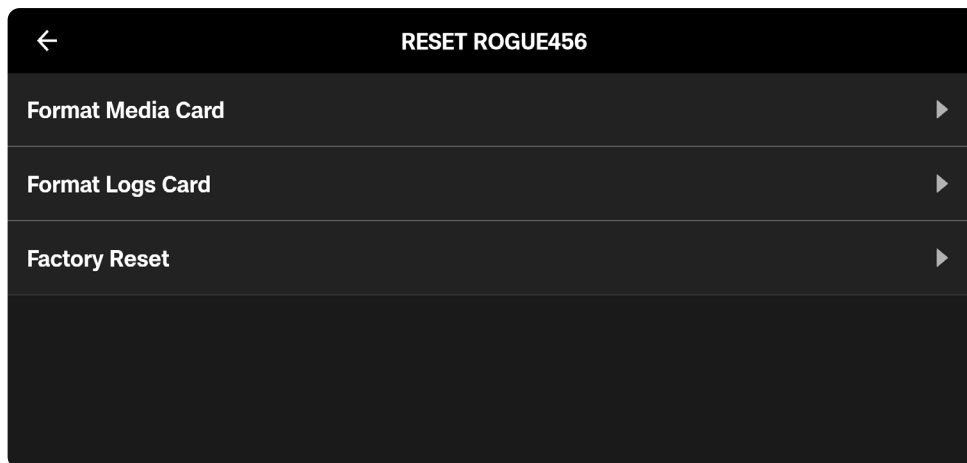

The **Media menu** displays a gallery of images and videos and allows you to manage captured images and videos. Media is encrypted or unencrypted depending on your settings.

To access the media viewer:

**Step 1 - Select the Global Settings icon and the Media menu**

- Individual thumbnails can be selected to view in full screen
- Select single or multiple to export
- Select the trashcan to delete

# Passwords



**CAUTION:** To maintain operational security and prevent conflicts with controller functionality, never sign in to personal or third-party accounts (such as Google Drive, Gmail, OneDrive, or other cloud services) on the X10 Controller. If you need to import maps or export logs, use the supported workflows provided by Skydio.



**CAUTION:** The password cannot be recovered or reset. Ensure that your password is entered correctly and is written down and stored in a safe location. If the password is lost, the controller will need to be replaced.

If you have set a password for your X10 system. It is recommended that you occasionally update your password per your organizations guidelines for length and complexity. To change your original password:

**Step 1 - Select the Global Settings menu and Information**

**Step 2 - Select change password**

# Monitoring Drones and Batteries in Skydio Cloud

If you've claimed your Skydio X10 drones and batteries in Skydio Cloud, you can track the total number of flights and flight hours for each device.



**NOTE:** Skydio X10 drones and batteries must be claimed in Skydio Cloud to view this flight data. Visit the Skydio Cloud Setup section of this manual for instructions on how to claim your devices.

## Skydio X10

Navigate to Reports > Activity. Here you can view the total number of flights and total flight time for each drone in your fleet.

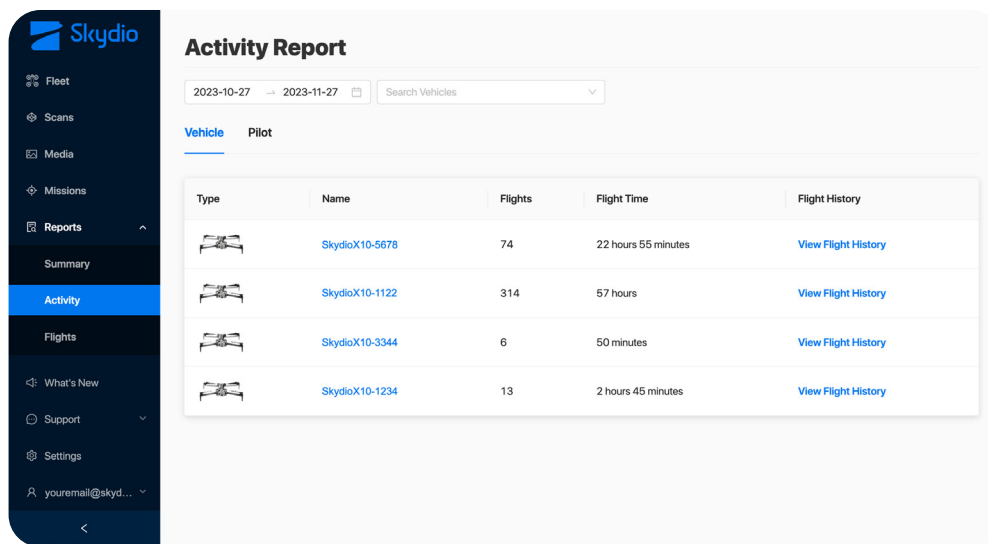

# Fleet Management

Under the Flights tab you can also view a list of all flights, their duration, launch time, and more.

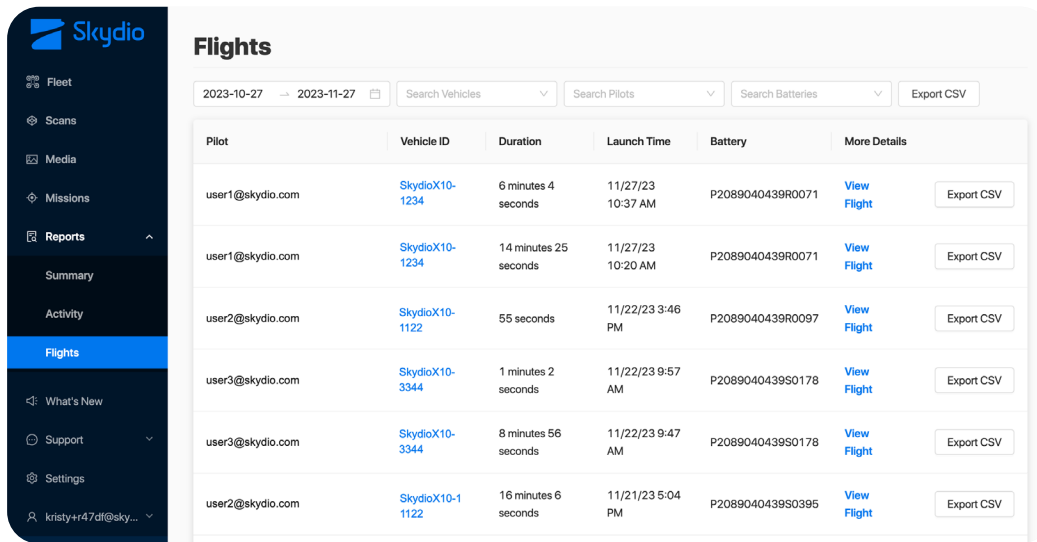

The screenshot shows the Skydio interface with the 'Flights' tab selected. The page displays a table of flight records. The table has columns for Pilot, Vehicle ID, Duration, Launch Time, Battery, and More Details. Each row includes a 'View Flight' link and an 'Export CSV' button.

Pilot	Vehicle ID	Duration	Launch Time	Battery	More Details
user1@skydio.com	SkydioX10-1234	6 minutes 4 seconds	11/27/23 10:37 AM	P2089040439R0071	<a href="#">View Flight</a> <a href="#">Export CSV</a>
user1@skydio.com	SkydioX10-1234	14 minutes 25 seconds	11/27/23 10:20 AM	P2089040439R0071	<a href="#">View Flight</a> <a href="#">Export CSV</a>
user2@skydio.com	SkydioX10-1122	55 seconds	11/22/23 3:46 PM	P2089040439R0097	<a href="#">View Flight</a> <a href="#">Export CSV</a>
user3@skydio.com	SkydioX10-3344	1 minutes 2 seconds	11/22/23 9:57 AM	P2089040439S0178	<a href="#">View Flight</a> <a href="#">Export CSV</a>
user3@skydio.com	SkydioX10-3344	8 minutes 56 seconds	11/22/23 9:47 AM	P2089040439S0178	<a href="#">View Flight</a> <a href="#">Export CSV</a>
user2@skydio.com	SkydioX10-1122	16 minutes 6 seconds	11/21/23 5:04 PM	P2089040439S0395	<a href="#">View Flight</a> <a href="#">Export CSV</a>

## Skydio X10 Batteries

Navigate to Settings > Devices > Batteries. Here you can view the total number of flights, total flight time, and cycles for each battery in your fleet.

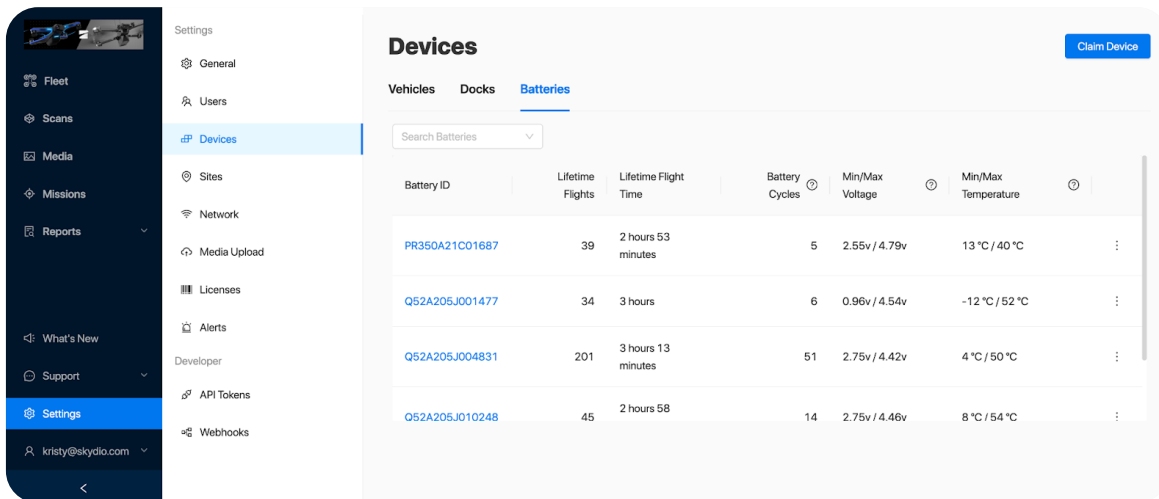

The screenshot shows the Skydio interface with the 'Settings' > 'Devices' > 'Batteries' path selected. The page displays a table of battery information. The table has columns for Battery ID, Lifetime Flights, Lifetime Flight Time, Battery Cycles, Min/Max Voltage, and Min/Max Temperature. Each row includes a 'Claim Device' button.

Battery ID	Lifetime Flights	Lifetime Flight Time	Battery Cycles	Min/Max Voltage	Min/Max Temperature	
PR350A21C01687	39	2 hours 53 minutes	5	2.55v / 4.79v	13 °C / 40 °C	<a href="#">Claim Device</a>
Q52A205J001477	34	3 hours	6	0.96v / 4.54v	-12 °C / 52 °C	<a href="#">Claim Device</a>
Q52A205J004831	201	3 hours 13 minutes	51	2.75v / 4.42v	4 °C / 50 °C	<a href="#">Claim Device</a>
Q52A205J010248	45	2 hours 58	14	2.75v / 4.46v	8 °C / 54 °C	<a href="#">Claim Device</a>

# Sending Skydio Support Logs



**WARNING:** *Powering off the drone immediately after a landing or a crash will result in missing data in the flight logs. Always allow your drone to complete postflight operations before powering off. Removing, swapping, or altering file names on the media card will impact the availability of the flight logs.*



**CAUTION:** *To maintain operational security and prevent conflicts with controller functionality, never sign in to personal or third-party accounts (such as Google Drive, Gmail, OneDrive, or other cloud services) on the X10 Controller. If you need to import maps or export logs, use the supported workflows provided by Skydio.*

Uploading your flight logs allows our support team to troubleshoot any issues or questions you may have.

**Do not reformat or factory reset your Skydio drone prior to contacting our support team.** Skydio will never review your videos or data without your permission.

# Fleet Management

When uploading to Skydio Support, monitor the upload progress of an individual flight directly from the Skydio Support Logs menu:

## Individual Flight Log Status

- **Not Started** – Log has not been uploaded
- **Partial** – Some data was uploaded, but the log is incomplete; when you retry, only the missing data will upload
- **Complete** – The log has been fully uploaded

## Individual File Status

- **Green** – Upload successful
- **White** – Upload failed; select the error icon (triangle) in the top right to view the files

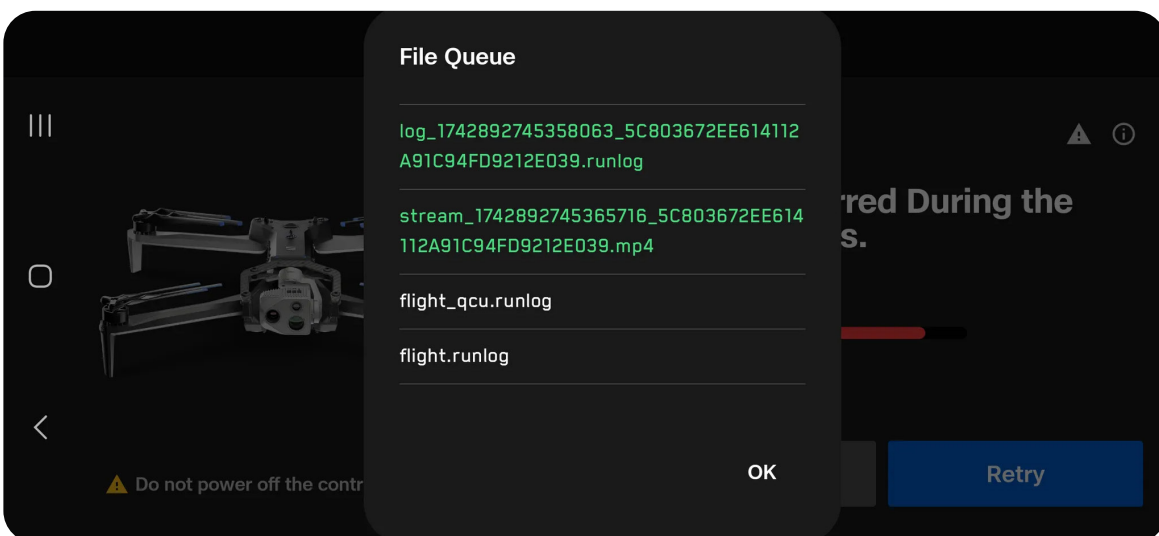
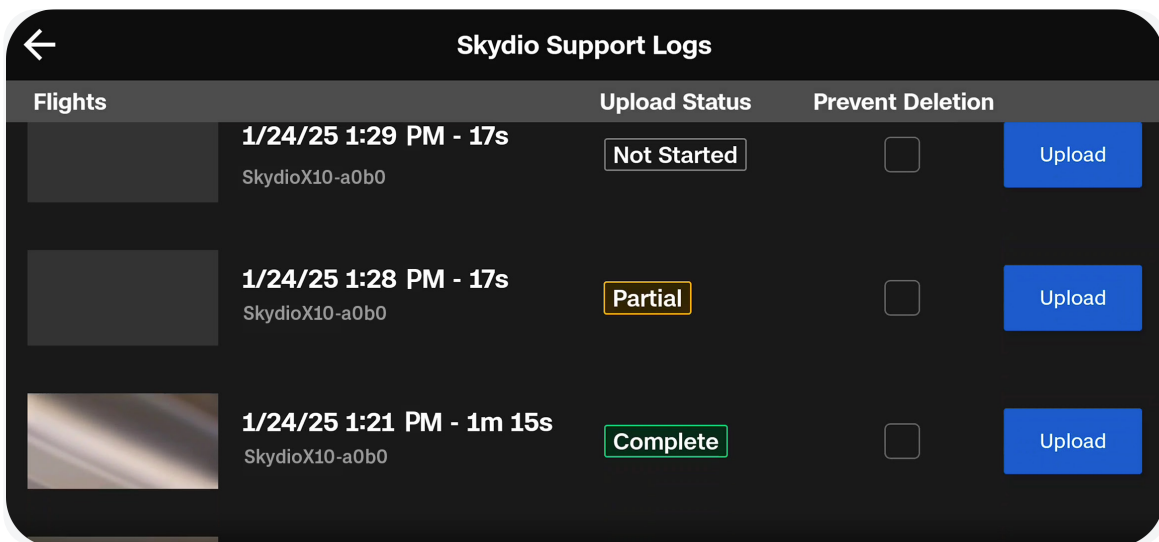

## Uploading Support Logs



**NOTE:** The transport of large support logs are not supported over 5G cellular.

### Step 1 - Power on Skydio X10 and the X10 Controller

Ensure your X10 Controller is fully charged.

### Step 2 - Navigate to Global Settings > Information

### Step 3 - Select Skydio Support Logs

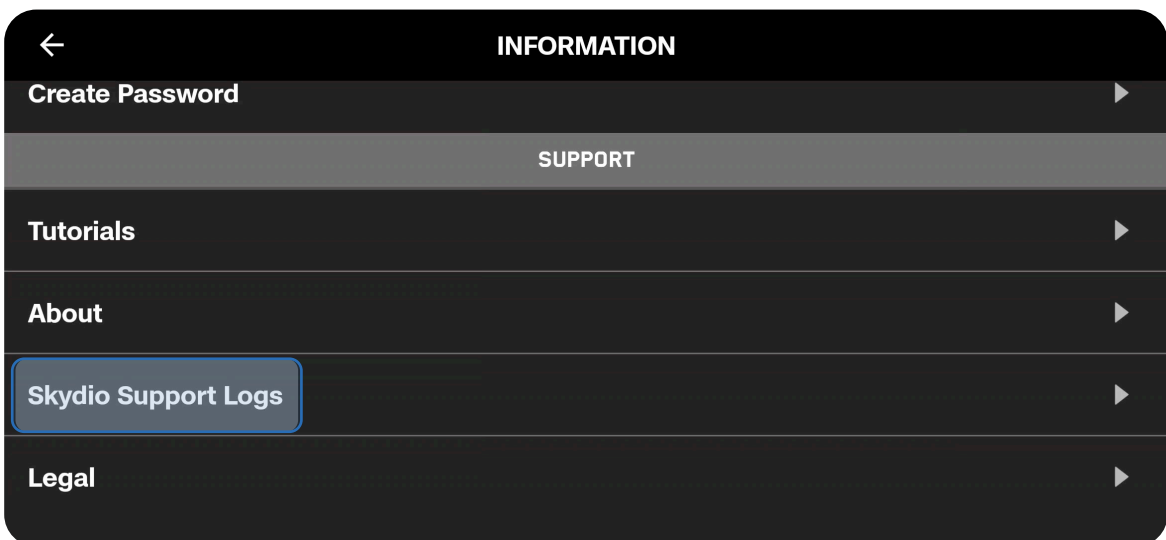
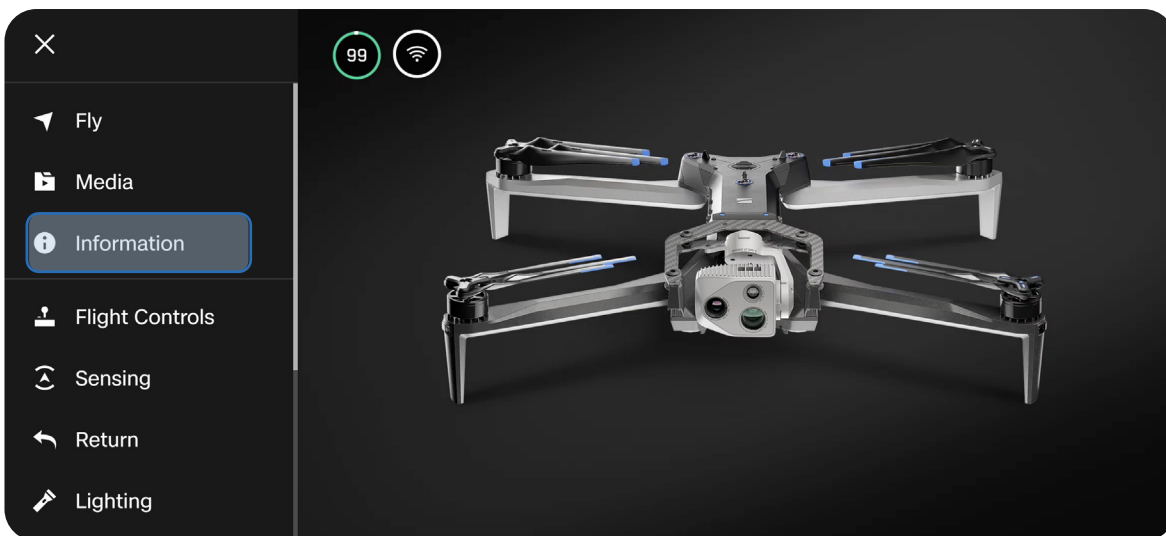

## Step 4 - Select Upload to Skydio Support

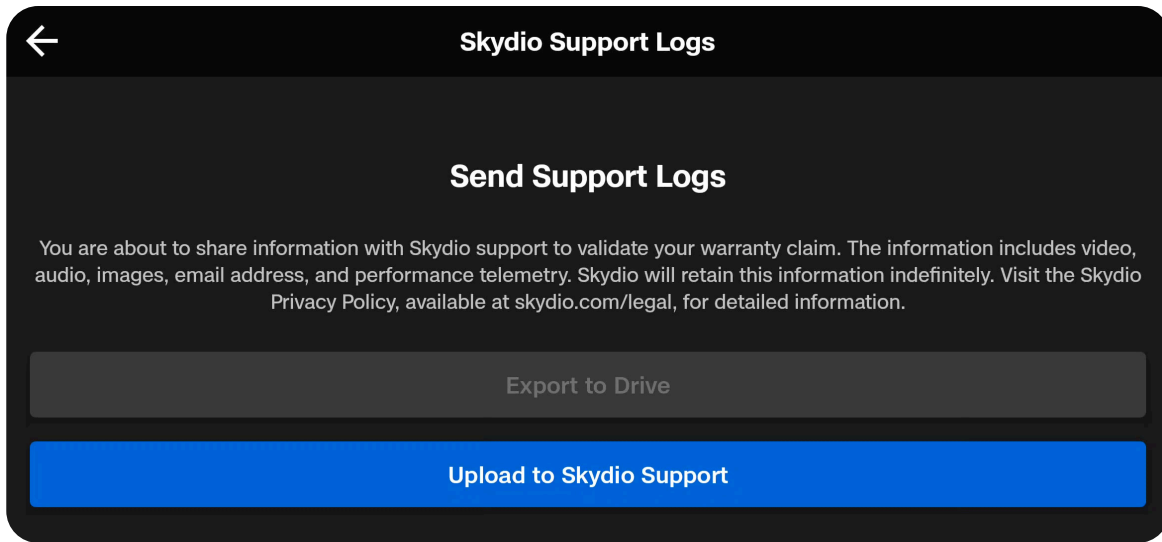

## Step 5 - Choose between a flight or controller logs

**Select Flight to Upload** includes all logs from a specified flight. This option will show you the history of all flights, organized by date and time. Select the individual flight you wish to upload.

**Send Controller Logs** uploads all flights saved on the controller from all flight history. This option allows you to sync logs whether or not you are connected to the drone.

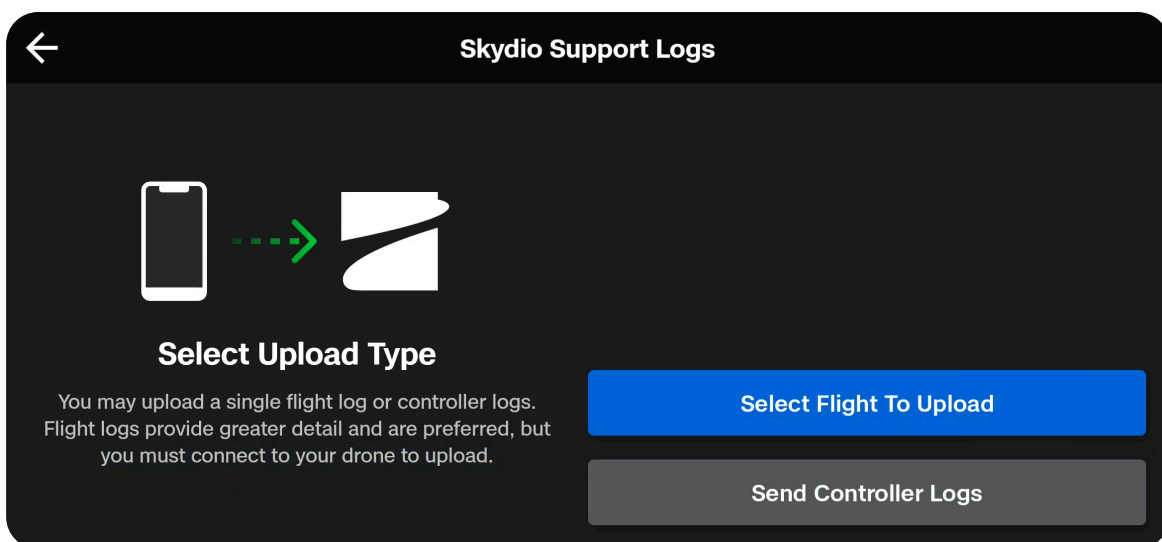



# Fleet Management

## Step 6 - Upload Flight Logs

If you selected **Select Flight to Upload** in the previous step, select which flight you wish to send to support.

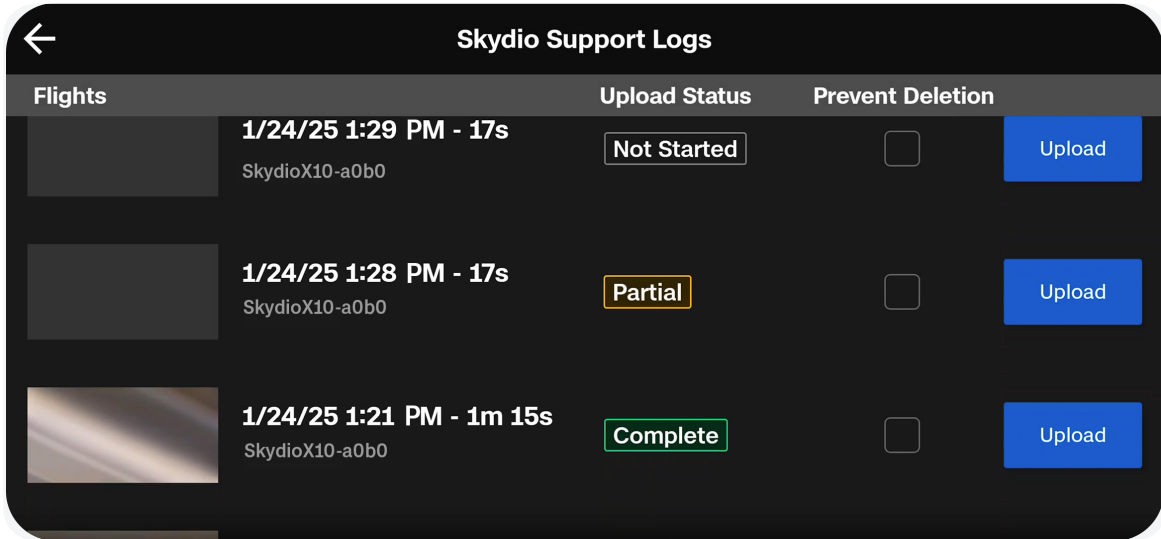
Wait as your upload completes. You will see a summary after the upload finishes.

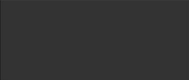

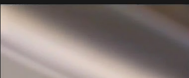
Flights	Upload Status	Prevent Deletion
 <b>1/24/25 1:29 PM - 17s</b> SkydioX10-a0b0	Not Started	<input type="checkbox"/> <span>Upload</span>
 <b>1/24/25 1:28 PM - 17s</b> SkydioX10-a0b0	Partial	<input type="checkbox"/> <span>Upload</span>
 <b>1/24/25 1:21 PM - 1m 15s</b> SkydioX10-a0b0	Complete	<input type="checkbox"/> <span>Upload</span>

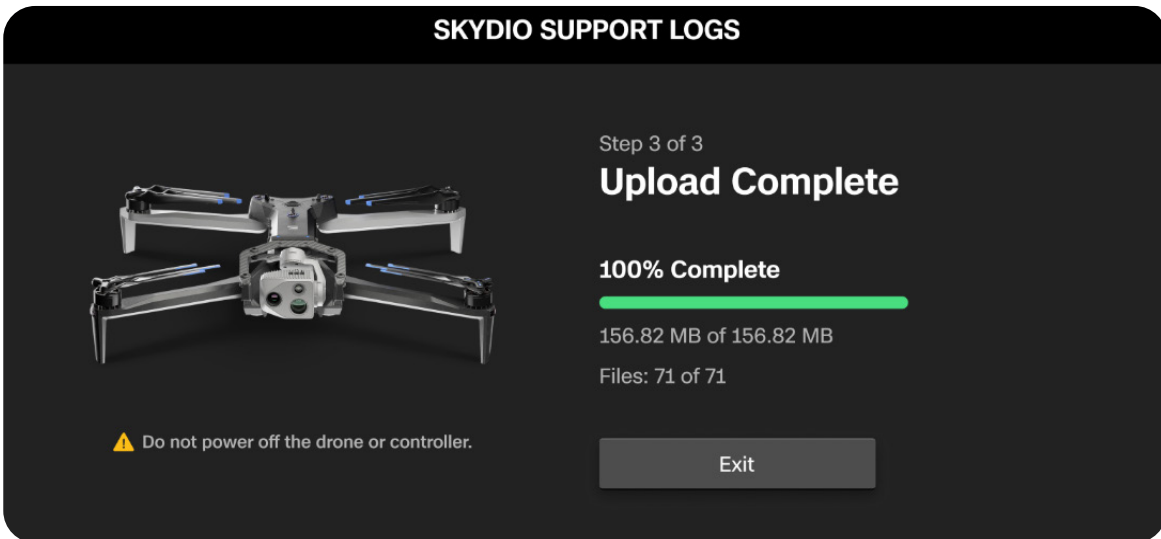

**SKYDIO SUPPORT LOGS**

Step 3 of 3

## Upload Complete

**100% Complete**

156.82 MB of 156.82 MB

Files: 71 of 71



 Do not power off the drone or controller.

Exit

## Uploading Debug Logs

Depending on the issue, Skydio Support may ask you to upload debug logs.

### Step 1 - Power on Skydio X10 and the X10 Controller

Ensure your X10 Controller is fully charged.

### Step 2 - Navigate to Global Settings > Information

### Step 3 - Select the name of your X10 under Devices

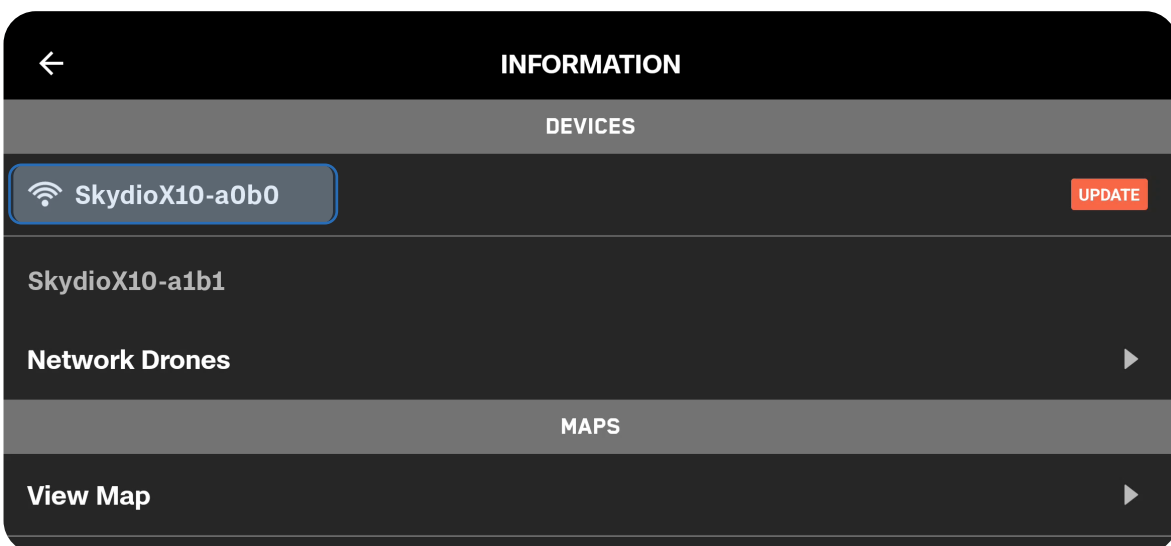
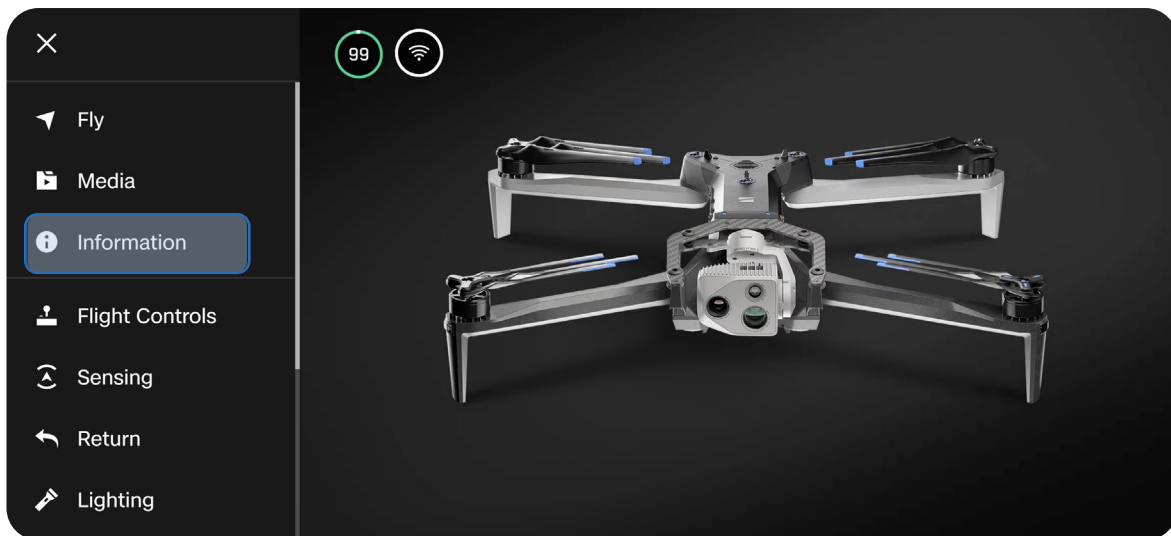

# Fleet Management

## Step 4 - Select Upload debug logs

It may take a few minutes for debug logs to upload to Skydio.

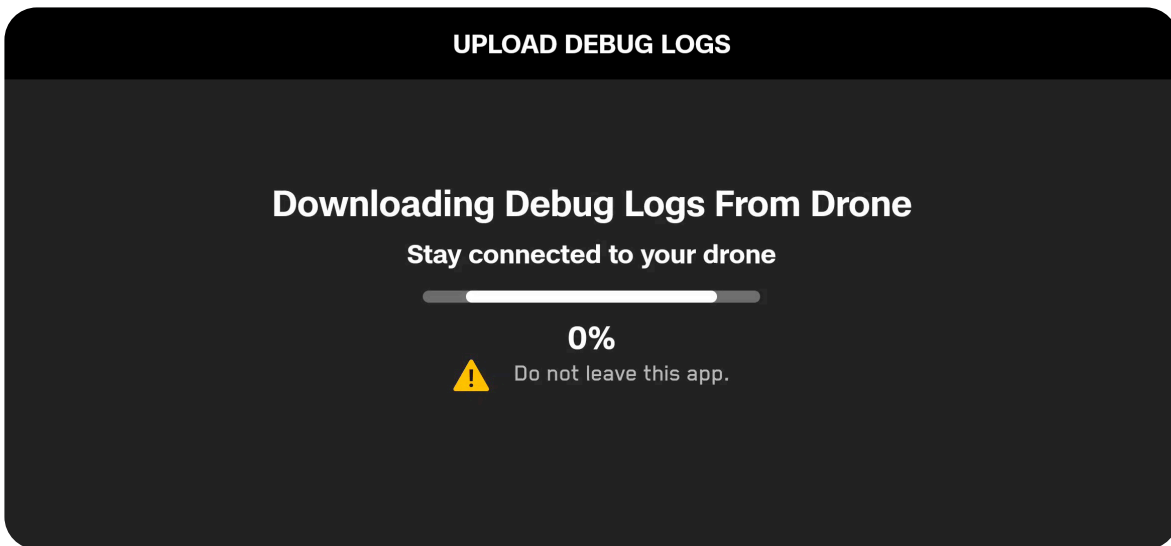
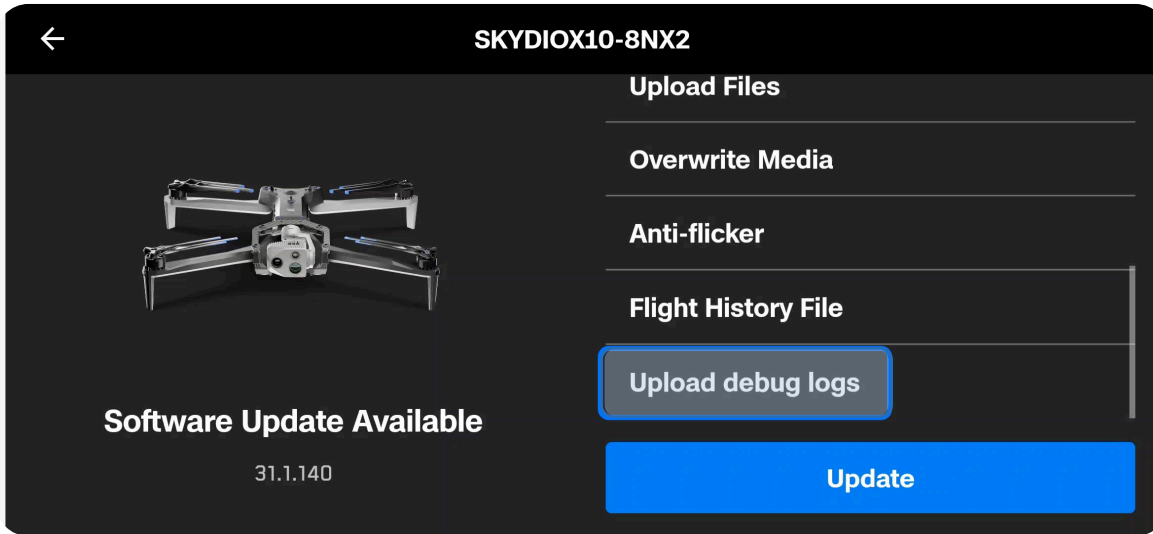



# Maintenance

This section covers

---

Maintenance Schedule

---

Physical Inspection

---

Cleaning the Flight System

---

Storage

---

Stowing Skydio X10

---

Differences between Skydio REV 1 and REV 2 Props

---

Propeller Maintenance

---

Sensor Package Maintenance

---

Battery Maintenance

---

# Maintenance Schedule

To optimize the performance of your Skydio X10 it's important to keep your drone updated, inspect your equipment, store your equipment properly, and occasionally replace your propellers and batteries.

<b>Action</b>	<b>Interval</b>
<b>Update system</b>	When an update is available (per your organization's guidelines).
<b>Clean drone navigation cameras</b>	Before each operational session, and after sessions in dust or precipitation. If flying in areas with high amounts of dust or debris, you may be prompted to clean your camera lenses before each flight.
<b>Replace propellers</b>	Per 250 hours of flight time
<b>Replace battery</b>	Per 300 battery cycles A battery cycle is the depletion of at least 80% of the charge. An undamaged and properly stored battery can be safely used beyond 300 cycles.
<b>Inspect and/or replace sensor package isolators</b>	When storing the X10 in hot temperatures (122°F/50°C to 131°F/55°C) and to ensure the system stays healthy, regularly inspect the Sensor Package Isolators during pre-flight inspections.

# Maintenance

Description	Performed By	Action	Frequency
Check for damage, wear, and proper alignment of the blades, propeller hub and interface to motor	Operator	Inspect	Routinely
Examine motor mounts for stability and damage	Operator	Inspect	Routinely
Inspect for external signs of wear or damage	Operator	Inspect	Routinely
Check light cover for damaged	Operator	Inspect	Routinely
Inspect Time of Flight sensor lenses for damage/Debris	Operator	Inspect	Routinely
Inspect fan exhausts for obstructions or damage	Operator	Inspect	Routinely
Ensure arms rotate smoothly without obstruction	Operator	Inspect	Routinely
Check for damage in the battery connection pins	Operator	Inspect	Routinely
Check for batteries for swelling	Operator	Inspect	Routinely
Examine navigation cameras for clarity and damage. Check for lens damage and recessed cameras	Operator	Inspect	Routinely
Manually spin motors to check for smooth operation	Operator	Check	10 flight hours
Check arm stops for proper functioning	Operator	Check	10 flight hours
Inspect for cracks or damage around arm hinge	Operator	Inspect	10 flight hours
Inspect landing legs for damage or wear	Operator	Inspect	10 flight hours
Inspect 6 navigation camera protective fins are present and free of damage	Operator	Inspect	10 flight hours
Check for damage or wear in the battery bay	Operator	Inspect	10 flight hours
Check fan inlets for blockages or damage	Operator	Inspect	10 flight hours
Examine sensor cameras for lens clarity	Operator	Inspect	10 flight hours
Check gimbal motors for movement	Operator	Inspect	10 flight hours
Inspect gimbal isolators for wear or damage	Operator	Inspect	10 flight hours

# Maintenance

Description	Performed By	Action	Frequency
Charge stored vehicle batteries	Operator	Charge	2 months
Charge stored controller batteries	Operator	Charge	2 months
Check visible motor wires for fraying or damage	Operator	Inspect	50 flight hours
Inspect all fasteners for tightness and wear	Operator	Inspect	50 flight hours
Inspect welds on arms for cracks or weaknesses	Operator	Inspect	50 flight hours
Inspect for damage on gimbal frame, confirm that screws are secure	Operator	Inspect	50 flight hours
Check attachment bracket for cracks, confirm C-Clip to bracket is installed tightly	Operator	Inspect	50 flight hours
Check all USB-C port seals for leaks or damage	Operator	Inspect	50 flight hours
Test lights for proper operation	Operator	Inspect	50 flight hours
Confirm attachment connector is free of debris	Operator	Inspect	On Install
Check cables for damage	Operator	Inspect	On Install
Confirm attachment are fully seated and torqued	Operator	Inspect	On Install
Inspect propeller hub for more than 10° of movement	Operator	Inspect	50 flight hours
Replace damaged or worn propellers	Operator	Replace	250 flight hours
Replace batteries as needed due to health warnings, visual inspection, or damage	Operator	Replace	On fault or damage
Replace battery lifecycle	Operator	Replace	300 cycles
Replace faulty motors or arms	Skydio	Replace	On fault or damage
Factory service to replace cameras and recalibration and repeat end of line tests	Skydio	Replace	On fault or damage
Replacement or update sensor	Skydio	Replace	On fault or damage

# Physical Inspection



**WARNING:** Carefully inspect your drone and environment before launching to ensure a safe flight.

- **Inspect the chassis** to ensure it is free of damage.
- **Inspect drone arms** and verify they are fully extended and free of damage.
- **Inspect the battery** and confirm it is securely seated prior to launching. Skydio X10 uses magnets to seat the battery which may attract metallic debris. Ensure the connector pins are free of debris or damage.
- **Clean the camera lenses and time of flight sensor** with a clean microfiber cloth. Cameras should be dust and smudge-free before flight.
- **Fan out the propellers and inspect** to verify they are firmly attached and properly seated in the motors and spin freely. Propellers should be free of cracks or damage. Do NOT fly with damaged propellers.
- **Inspect the sensor package before powering on** and ensure it moves freely and is not damaged, and remove the Gimbal Stabilizer Clip before flying.
- **Ensure all USB-C and microSD card seals are secured** over the ports.
- **If using an attachment, inspect the connections** and confirm cables are fully seated and thumb screws are secure. Loose or partially connected cables may detach during flight and cause damage.
- **Check your surroundings before launching** to ensure a safe environment for flight.
- **Point the controller cover/antennas toward the drone** for maximum wireless performance.
- **Verify batteries and the controller are fully charged** before flying.
- **Check for drone and controller updates** before flying.

# Cleaning the Flight System

It is recommended to wipe down your drone after flights in environments with significant dust or debris.



**WARNING:** Do not submerge your drone or batteries or place them under running water. Water volumes from flight in precipitation are much lower than those from a faucet or hose. Water may get into areas where the drone is not designed to withstand and you may compromise the sensors.

- Wipe down your drone with a dry or water-damp microfiber cleaning cloth.
- Only use lens cleaner on cameras.
- Do not submerge your drone or batteries.
- Do not place your drone or batteries under running water.
- Use a compressed air canister to remove any debris in hard to reach areas.
- If needed, mild soap and water may be used to remove heavier dirt or debris. Avoid getting any soap near ingress areas on the drone.
- Keep all the drain holes on the drone and battery clear. If any debris is blocking a drain hole (e.g., mud), use compressed air or gently scrape with a toothpick to remove.

# Storage

- Do not store Skydio X10 while wet. After flying in precipitation, allow the drone to air dry in a dry, temperature-controlled environment before stowing. Visit the Flying in Precipitation section of this manual for more information.
- Store batteries at room temperature 71°F - 82°F (22°C - 28°C) for optimal performance and longevity.
- Store batteries in a cool, dry area with less than 75% relative humidity. Do not store your batteries in extreme environmental conditions.
- Batteries in an idle state (14 days of idle time with no flights) will start to self-discharge in an effort to retain capacity. This may take several days to complete and it is normal for the battery to be slightly warm during this discharge process.

# Stowing Skydio X10

## Step 1 - Wait for postflight tasks to complete

If the battery is low while performing a longer postflight task, such as Onboard Modeling with Map Capture, ensure the drone is plugged into a power source.

- Powering off or removing the battery during postflight tasks will result in loss of data

## Step 2 - Power off Skydio X10 and the X10 controller

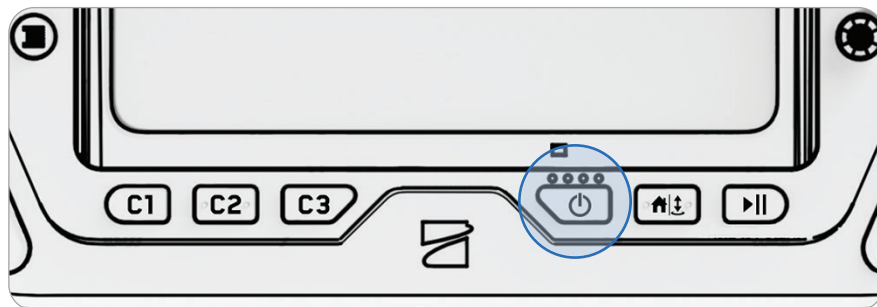
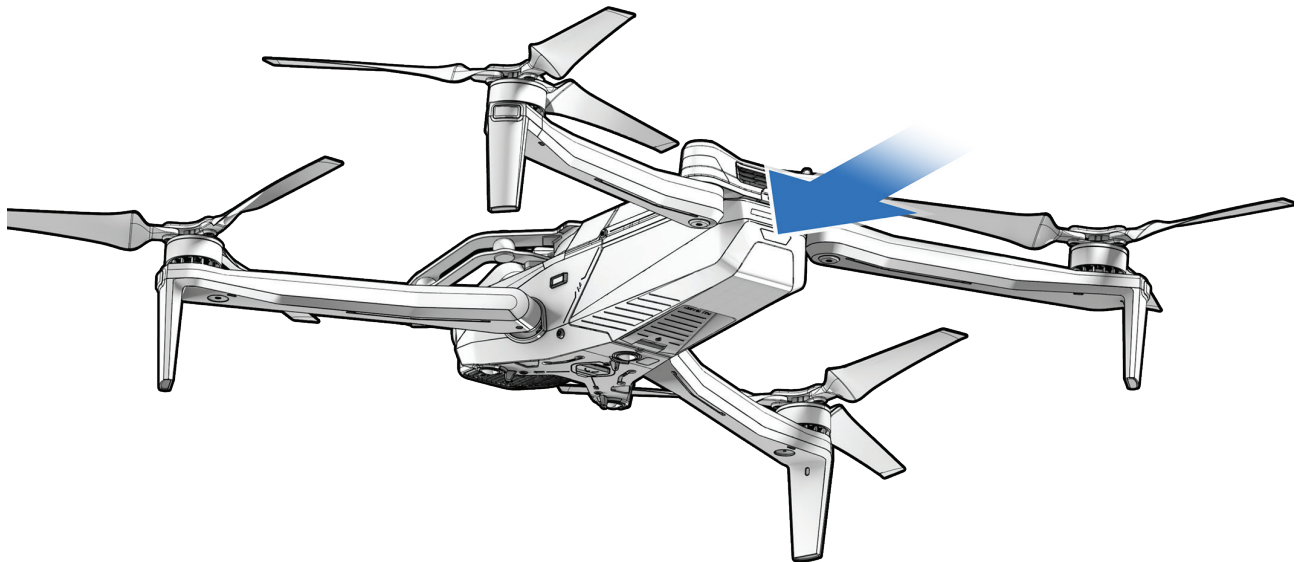

## Maintenance

---

### Step 3 - Fold in the front arms

Hold the drone with the sensor package facing away from you. Gently pull the arm toward the back of the drone and rotate until it is tucked into place.

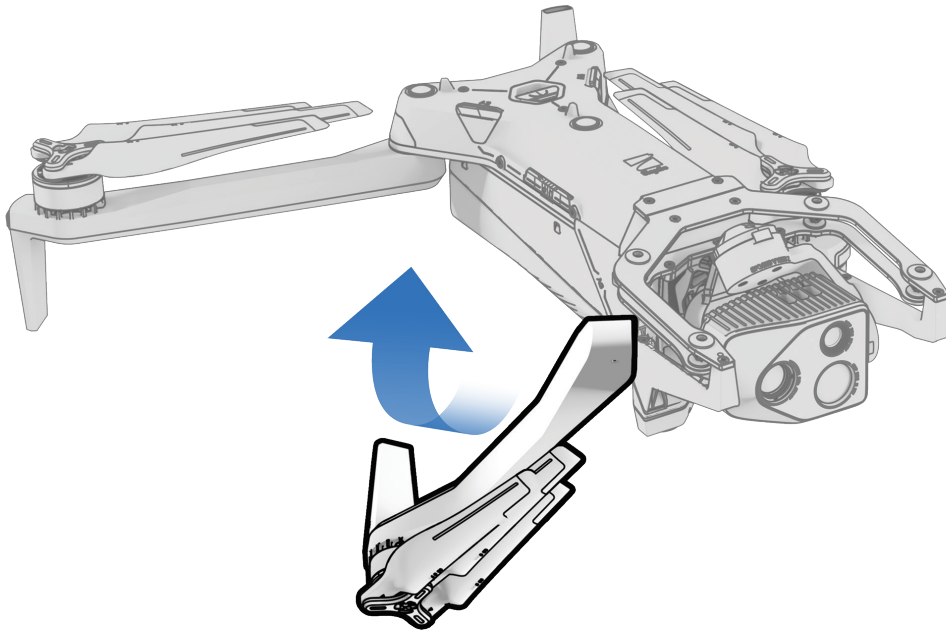

### Step 4 - Fold in the rear arms

Push laterally toward the chassis. Gently continue until you meet resistance.

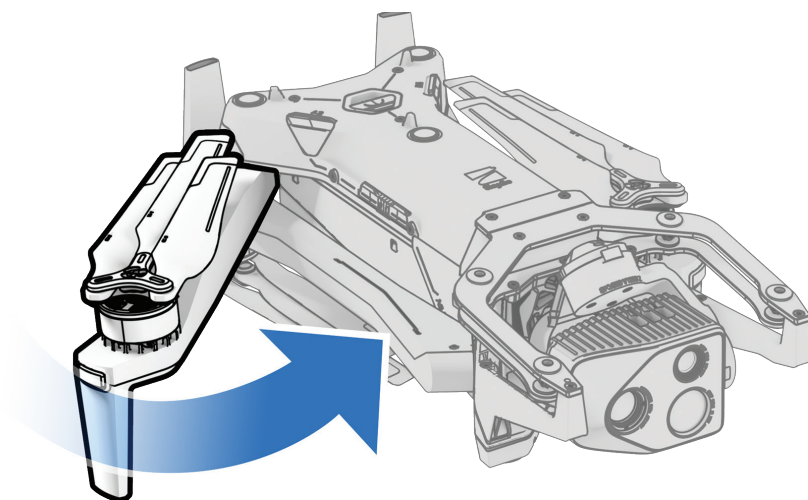

## Maintenance

---

### Step 5 - Attach the gimbal stabilizer clip

Hold the sensor package and gently reattach the lock to the top of your drone.

- Ensure you are using the correct gimbal stabilizer clip for your sensor package. The clip label should match your gimbal version (for example, "VT300-Z REV2"). Using the wrong clip will prevent proper fit.

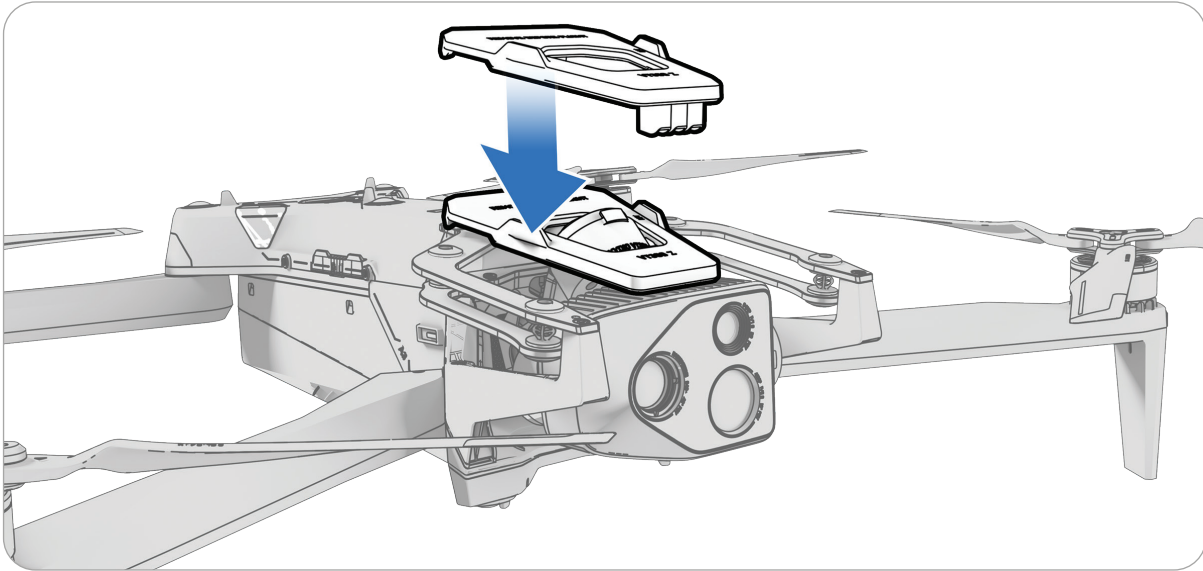

**NOTE:** Refer to the *Flying in Precipitation* section of the *Skydio X10 Operator Manual* for steps on how to properly store your drone after flight in precipitation.

# Differences between Skydio X10 REV 1 and REV 2 Propellers



**NOTE:** Propellers are consumable items and should be planned for and replaced as part of a regular maintenance schedule when they reach the end of their usable life. To purchase new propellers, work with your Skydio account team.

Revision 2 (REV 2) Propellers enhance durability and reliability, and addresses an accelerated propeller hub wear issue seen with the previous Revision 1 (REV 1) design per NTO: Skydio X10 Accelerated Propeller Hub Wear.

The REV 2 propeller design features two primary changes:

- **Materials** - Skydio shifted to using low-friction plastic as we found that this was most capable of handling high aerodynamic loads at the interface of propeller hub and the motor shaft
- **Stabilizing Hoop** - Added to reduce strain on the quick-release attachment point and improve structural integrity under high-stress/high-speed flight conditions

Perform routine preflight inspections to ensure your propellers are in good working condition. Skydio X10 propellers are designed for up to 250 hours of useful life under normal flight conditions.

Skydio recommends drones that are still flying with REV 1 propellers and accumulate flight hours primarily via high-stress profile conditions undergo a visual propeller hub inspection every 5 flight hours. High-stress flight conditions include:

- Sustained flight airspeed above 33 mph (53 km/h)
- Aggressive or max throttle, pitch, and yaw
- Flights conducted in high wind or gust conditions

## Maintenance

If propellers are reaching the end of their cycle count or accelerated propeller wear is detected, you will see the following notification on the controller:



# Inspecting Propeller Hubs

The inspection procedure involves observing the degree of movement in the propeller hub and the motor shaft.

**Step 1 - Place Skydio X10 on a stable, flat surface**

**Step 2 - Grasp the motor between your index finger and thumb with one hand**

- Grasp the propeller hub with your other hand

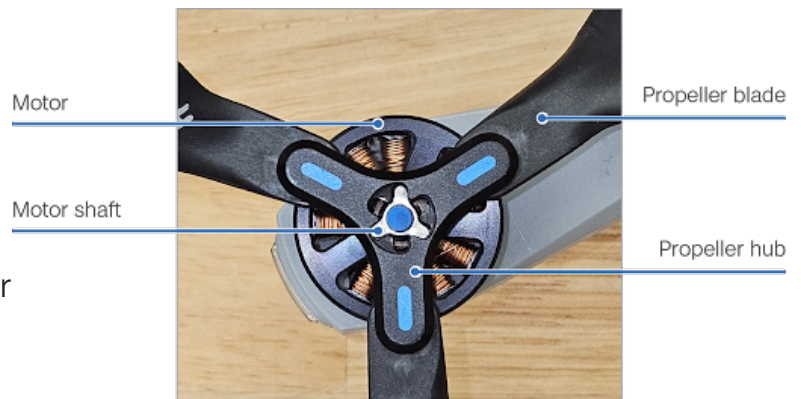

**Step 3 - Apply firm opposite torsion between the propeller hub and the motor in both directions without pressing down**

**Step 4 - Look and feel for movement of the motor shaft compared to the pocket it rests in within the propeller hub**

Flight worthy propeller hub:

- Propellers with less than 10 degrees of movement
- The top surface of the motor shaft is not occluded by any portion of the propeller hub
- There is no accumulation of gray dust around the top of the hub

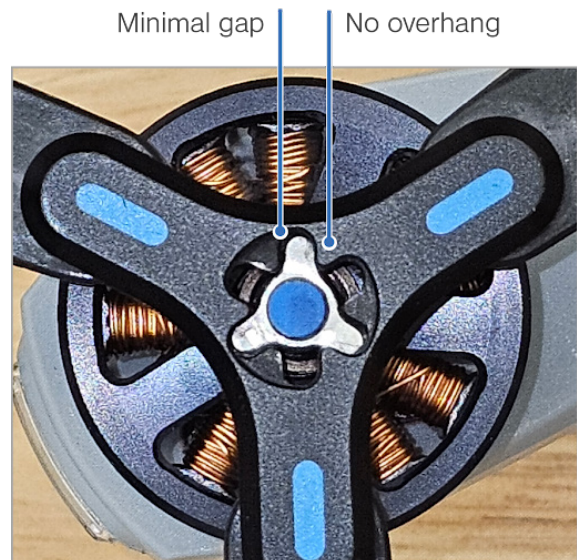

# Inspecting Propeller Springs

The X10 propeller springs keep the propeller in place and allows for easy installation and removal of the propeller. The springs can get damaged after high flight hours or with REV 1 propellers.

**Inspect all four propeller springs. If all conditions are true, the drone propeller springs must be replaced. Reach out to Skydio Support for further assistance:**

- Spring is damaged or broken in pieces
- The motor spins freely while hand spinning

If the motor does not spin freely, contact the Skydio Support team for next steps as the drone will need to come back to Skydio for repair.

To request spare parts for propeller spring repairs, contact the Skydio Support team.

# Replacing Propellers



**WARNING:** Propellers with hairline cracks or large breaks, chops, or bends should be replaced immediately. Do **NOT** fly Skydio X10 with propellers that are not in good condition as serious bodily harm or injury may occur.

For optimal performance, Skydio recommends replacing your propellers **after 250 hours of flight time** or whenever you notice any damage. Organization Admins have the ability to enable Propeller Hour Tracking in Skydio Cloud Settings.

## Step 1 - Remove old or damaged propeller set

Hold onto the motor with one hand and take the propeller hub in the other. Press down on the propeller hub and twist to release.

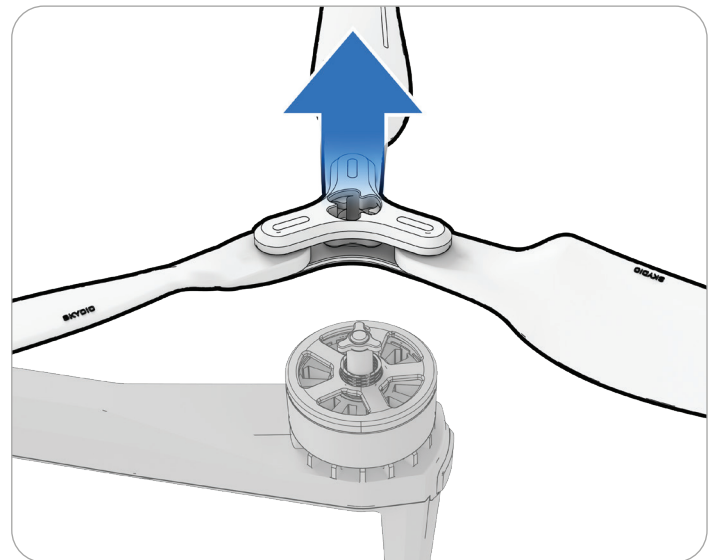
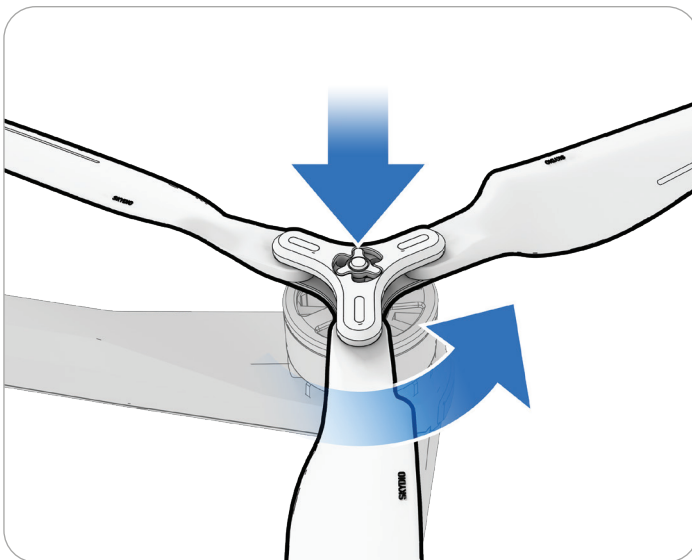

**NOTE:** You will need to twist either clockwise or counterclockwise depending on the motor.

## Maintenance

### Step 2 - Identify the propeller set that matches the motor

Match the replacement set of propellers to the color on the motor.

### Step 3 - Inspect for any debris

Inspect the motor to ensure there is no dirt or debris.

### Step 4 - Install new propeller set

Hold onto the motor with one hand and take the propeller hub in the other. Flip the propeller hub so the opening on the hub aligns with the motor. Press down and twist to lock in place.

Be gentle and do not force the fitment. If the propeller set does not fit on the motor it might be the incorrect set or side.

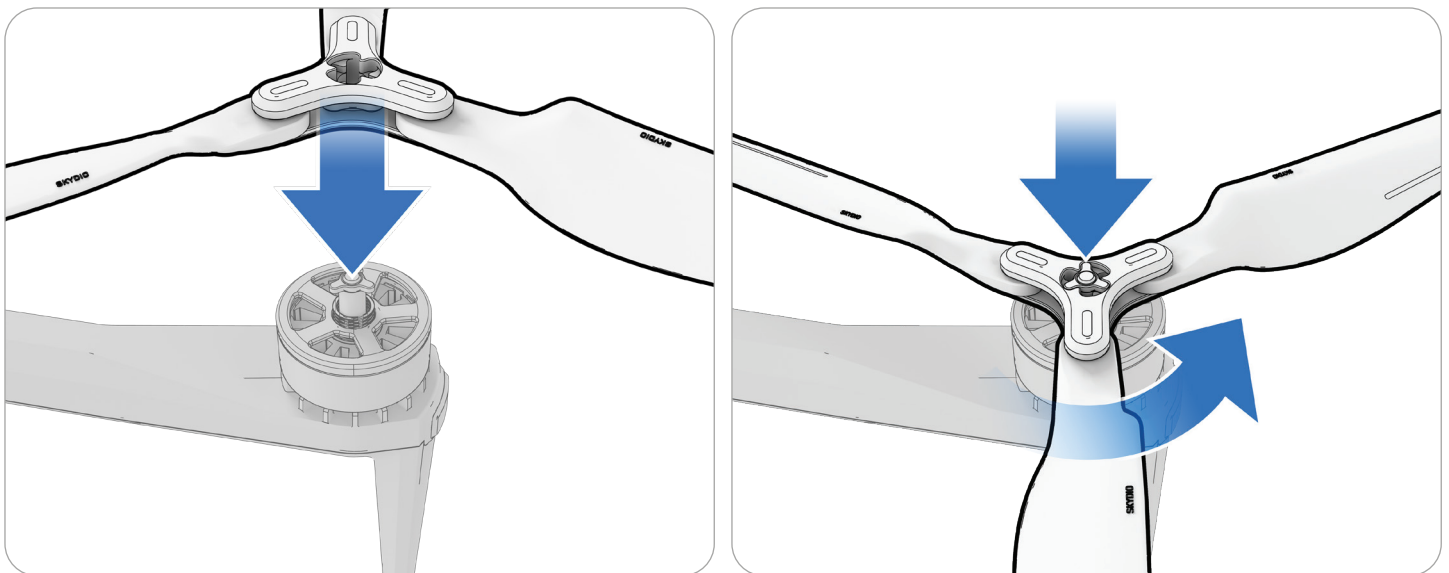

**NOTE:** You will need to twist either clockwise or counterclockwise depending on the motor.



**TIP:** The total number of flight hours for your drone is tracked in Skydio Cloud. Consider replacing all propellers at the same time for ease of tracking total propeller flight time.

# Removing the Sensor Package



**WARNING:** Always hold the sensor package by the frame. Do not hold the sensor package camera housing.

**Step 1 - Remove your sensor package lock and the battery**

**Step 2 - Loosen the 4 sensor package screws**

- Using the torque driver provided in your kit
- The 4 screws will remain attached to the sensor package frame

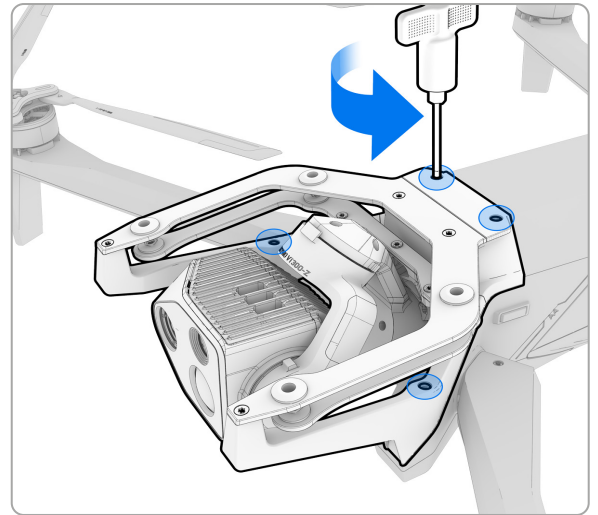

**Step 3 - Remove the sensor package**

- Hold the edges of the sensor frame
- Gently rock side to side while lifting up to disengage from both connection points on the airframe.
- Do not pull off at an angle, do not use a peeling motion, lift straight up while gently rocking the sensor package until it is completely off the mounting posts.

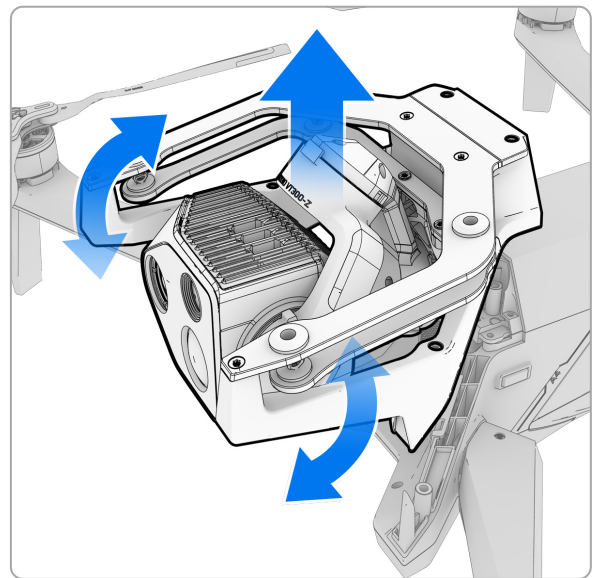

**Step 4 - Reattach the sensor lock and store in the sensor case**

# Installing the Sensor Package

**Step 1 - Remove your sensor package lock**

**Step 2 - Remove the battery from the X10**

**Step 3 - Locate the 4 screw holes on the airframe**

**Step 4 - Install the sensor package**

- The mounting posts on the airframe will guide the alignment of the embedded screws on your sensor package
- Insert the sensor package straight down

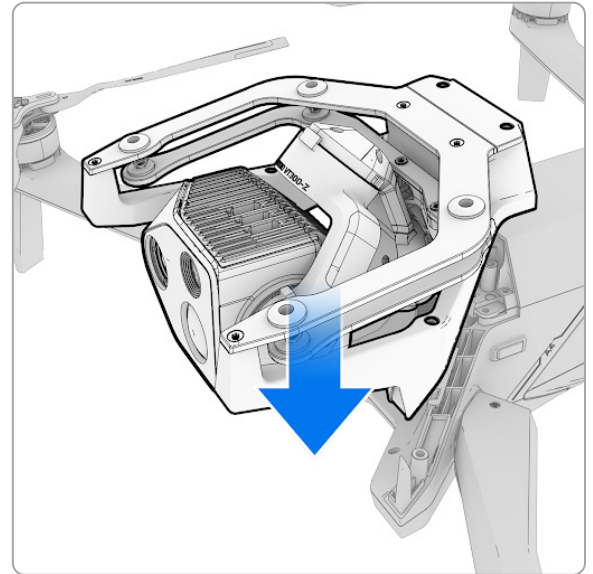

**Step 5 - Press sensor package into place**

- Firmly press straight down between the two screws on top of the sensor frame until it locks in place

**Step 6 - Tighten sensor package screws**

- Use the provided torque driver to tighten all four screws
- The torque driver will click when you reach the appropriate torque to prevent over-tightening

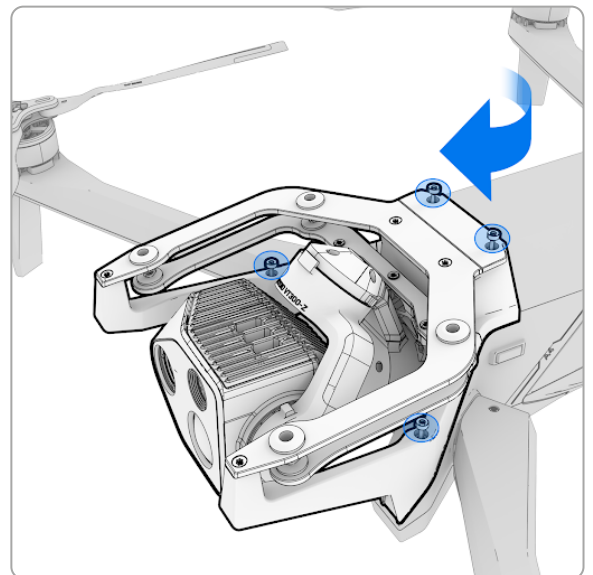

**Step 7 - Insert the X10 battery and power on your drone**

**Step 8 - Power on your controller and wait for your devices to pair**

- Your drone will boot up and calibrate the new sensor package

# Replacing Sensor Package Isolators

The Sensor Package Isolators help stabilize the cameras and provide a smooth, crisp image, even in tough flight conditions.

When storing the drone in hot temperatures (122°F/50°C - 131°F/55°C), Skydio recommends regularly inspecting the Sensor Package Isolators.

To ensure the Skydio X10 system stays healthy, regularly inspect the Sensor Package Isolators during pre-flight inspections.

If any of the following conditions are present, replace the isolator:

- Abnormal wear
- Tears
- Any separation on the isolator, especially where the inner gaskets meet the main connector

Visit [support.skydio.com](https://support.skydio.com) to watch a video about replacing sensor package isolators.

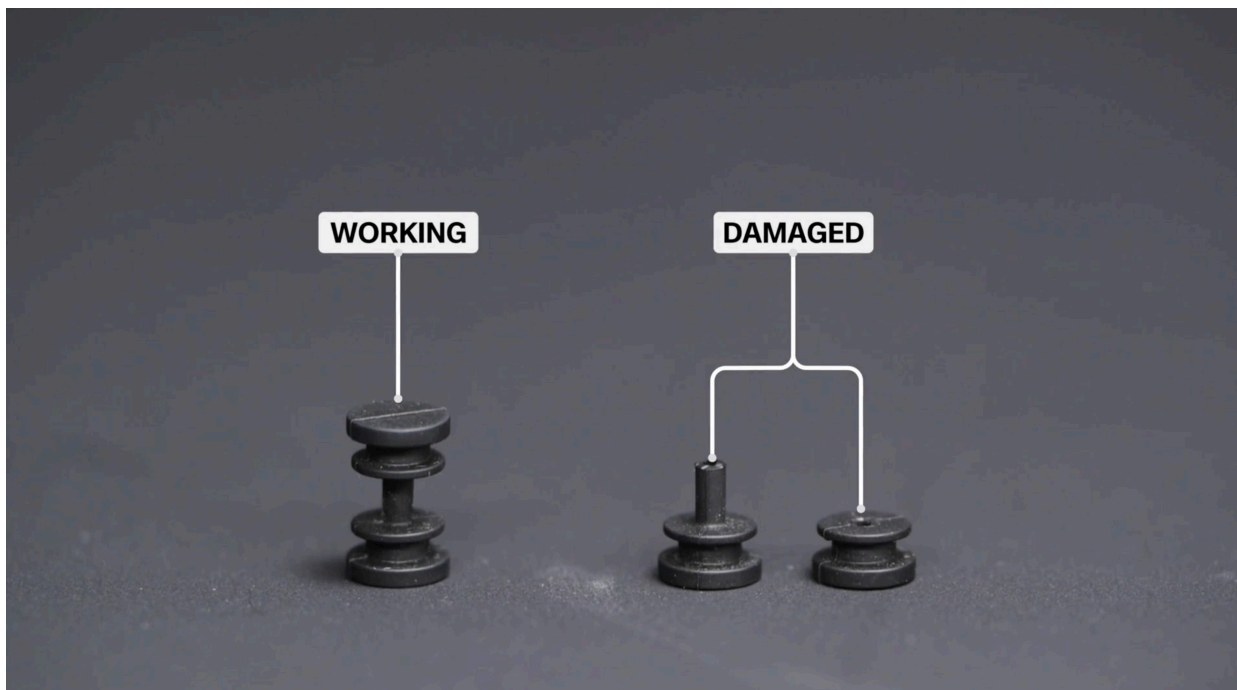

# Removing an isolator

### Step 1 - Power off and remove the Sensor Package Lock

Leave the sensor package attached.

### Step 2 - Remove the isolator from the upper bracket

Gently pull the top part of the isolator down through the upper bracket.

When pulling down, pinch the edges of the inner gasket to give you more leverage and avoid causing a tear. Use your other hand to help push through the top part of the isolator down through the hole if needed.

### Step 3 - Remove the isolator from the bottom bracket

You can slightly offset the bracket to give you more working space.

Pinch the edges of the inner gasket, this time pulling up. It helps if you use a slight peeling motion as well.

# Installing an isolator

### Step 1 - Insert the isolator into the bottom bracket

One side of the isolator will have a hole in it. This end goes on the lower bracket. Start in between the upper and lower brackets. Thread the edge of the circular piece through the hole in the lower bracket, then pull the rest through from the bottom until fully seated.

Roll and pull the edges down if needed to ensure the isolator is fully seated.

### Step 2 - Insert the isolator into the upper bracket

Thread the remaining half of the isolator through the hole in the upper bracket. You may have to gently align the upper bracket with the hole, as it is designed to be slightly offset

Once you thread an edge through, pinch and pull until the isolator is fully seated.

Check the edges and roll into place if necessary. Once finished, it should match the other isolators on the drone.

# Batteries

Skydio X10 uses lightweight, rechargeable lithium polymer batteries (LiPo) that provide higher specific energy than other lithium batteries. Following the guidelines listed below will ensure long battery life and safe operation.

### Lifespan

The lifespan of a Skydio X10 battery is 300 battery cycles. A battery cycle is the depletion of at least 80% of the charge. After this point, you may experience a decline in charging and performance. Battery life is highly dependent on your use case, and Skydio recommends replacing your battery when the flight time has degraded below what is acceptable for your use case.

### Temperature

- Charging should be completed in an open area
- It is normal for the device to become warm to the touch
- Do not operate Skydio X10 or charge batteries at temperatures below -4°F (-20°C)
- Do not charge your batteries when the ambient temperature is above 113°F (45°C)

### Storage

- Fully charge and discharge vehicle and controller batteries every two months
- Store batteries at room temperature 71°F to 82°F (22°C to 28°C)
- Store batteries in a cool, dry area with less than 75% relative humidity
- Batteries in an idle state (14 days of idle time with no flights) will start to self-discharge in an effort to retain capacity. This may take several days to complete and it is normal for the battery to be slightly warm during this discharge process.

### Damage

- Do not disassemble the batteries
- Avoid dropping or striking the batteries
- Do not attempt to use batteries that are damaged, dented, or ruptured after a crash or drop
- Do not immerse the batteries in water or other liquids
- Lithium polymer batteries can leak, overheat, melt, release harmful gas, burst or ignite when exposed to heat, water, and other liquids or when pierced, punctured, or ruptured
- If any substances leak from the battery pack and get into your eyes, do not rub them. Seek medical attention immediately!
- Contact your local waste facility to verify if lithium polymer batteries are permitted for disposal
- Do not insert any foreign material into the battery terminals
- Do not disassemble the battery enclosure

# Battery Disposal



**WARNING:** *If your battery shows signs of damage (cracks or swelling), place the battery in a non-flammable enclosure away from people and contact your local hazardous waste recycling agency for safe handling and disposal procedures.*

Your Skydio X10 batteries are not considered household waste. Properly dispose of e-waste and lithium polymer batteries in accordance with your local laws and regulations. Visit the EPA or your country's environmental regulatory agency website for more information about disposal and recycling options for batteries.

### **To dispose of your Skydio battery:**

Lithium batteries must be disposed of at e-waste collection points or battery-recycling drop-off locations. Take care when disposing of your Skydio battery. Contact your local waste facility to verify if lithium polymer batteries are permitted.

- Do not throw out batteries in your regular household garbage or recycling bin
- Do not burn batteries in a fire; they may explode
- Do not mix damaged, and non-damaged batteries
- Avoid storing batteries in metal containers

# Resetting the Skydio X10 Controller

If your Skydio X10 Controller is in an unresponsive or other off-nominal state, you may need to reset it. There are two ways to do this:

- **Hard reset** allows you to power off the controller and reboot. While this option forces the controller to power cycle, helping to resolve temporary issues like freezing, it does not trigger a full reset or restore your controller to its original factory state.
- **Recovery Mode** is designed for more severe issues, such as when your controller is fully unresponsive. It gives you the ability to perform a factory reset, clearing all device data and returning the controller to its initial setup state—similar to when you first took it out of the box.

## Hard Reset

### Option 1 - Perform a hard reset

1. Simultaneously press and hold the C3 and Power buttons for 10-15 seconds
2. Wait for your controller to reboot

If that does not work, go to Option 2.

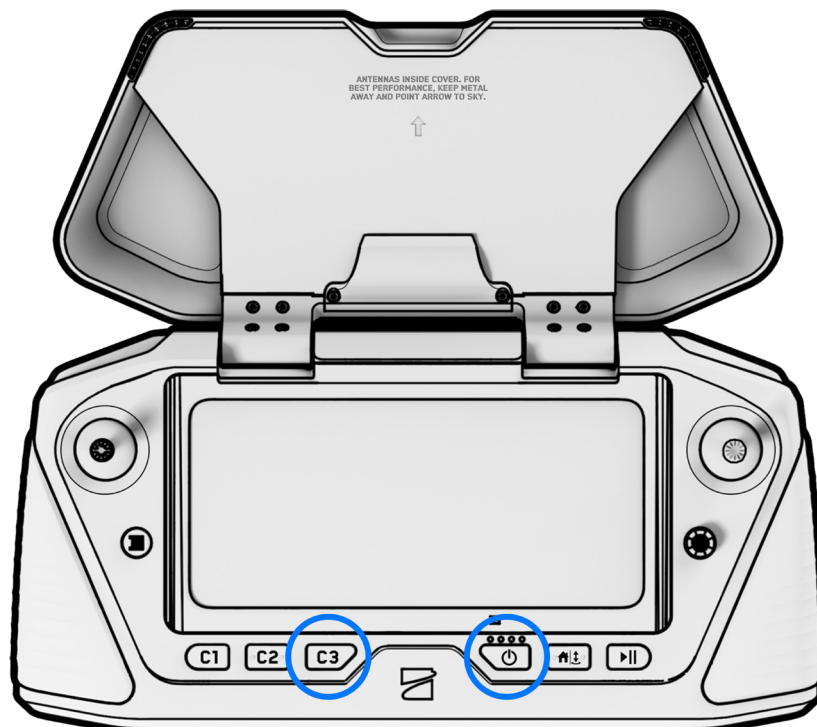

# Troubleshooting

---

## Option 2 - Reset your controller screen

1. Press and hold the small reset button on the front of the controller
2. Select Power Off or Restart
3. The controller will restart or power off, allowing you to power it back on again



### Recovery Mode

If your X10 Controller has entered an unusable state that does not resolve with the reset steps above, and you are unable to use the Factory Reset option within the Information menu, you may need to enter Recovery Mode.

**Step 1 - Hold the power button until you are prompted to power off the controller**

**Step 2 - Hold PAUSE, R1, and R2 simultaneously**

Select Enter Recovery Mode.

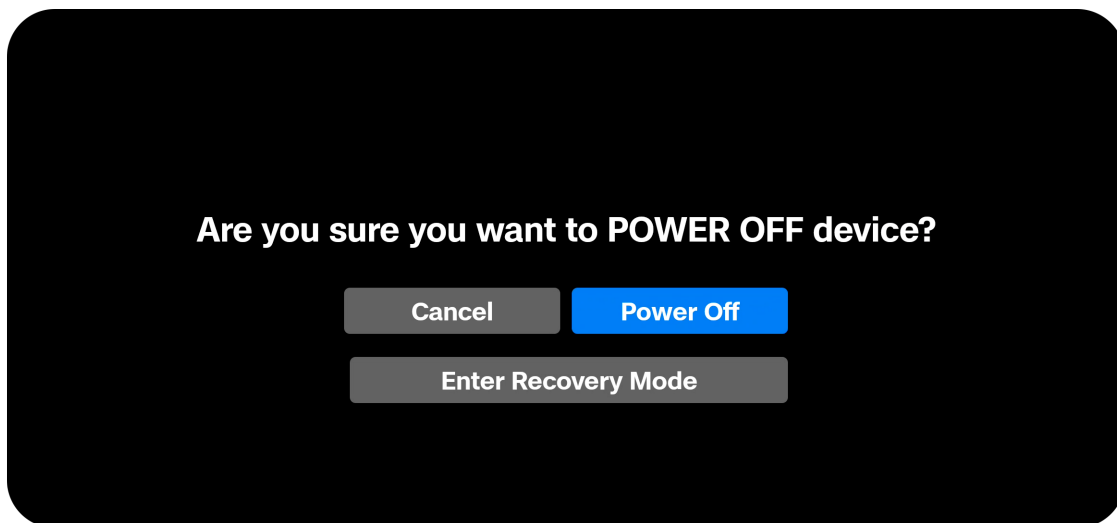

**Step 3 - Select Clear App Data**

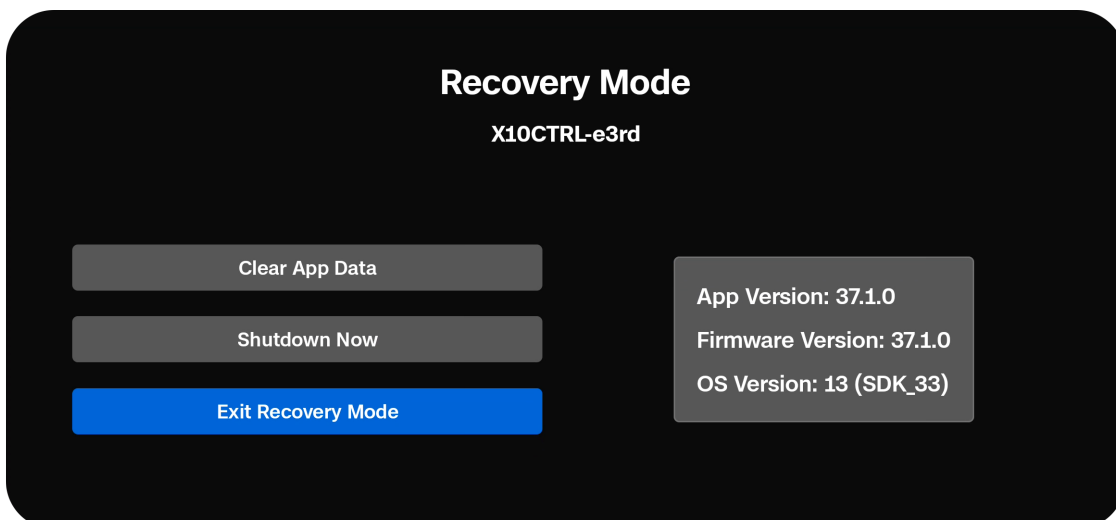

# Troubleshooting

---

## Step 4 - Select Clear Data

This will begin the factory reset process, wiping all settings and stored data.

You will see a notification that confirms app data was successfully wiped.

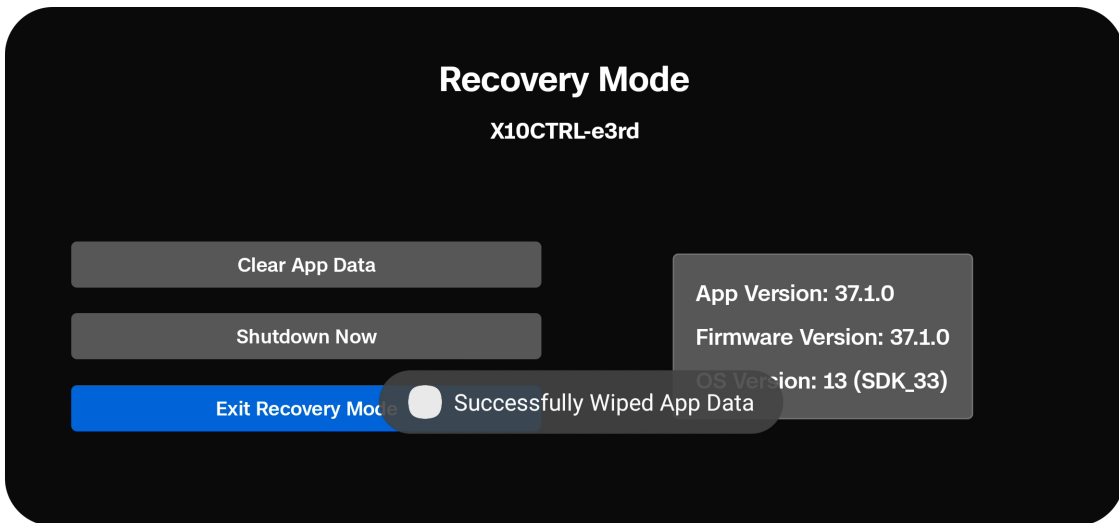
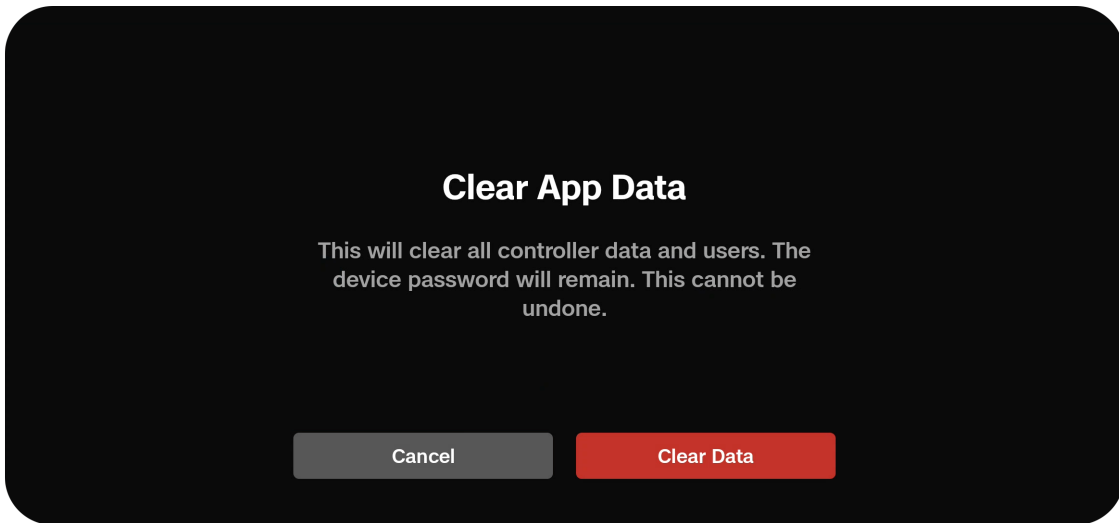

### Step 5 - Select Exit Recovery Mode or power off

**Exit Recovery Mode** - You will be prompted to begin setup as if the controller is brand new. This includes pairing the controller with your drone and reconfiguring your settings.

**Power off** - The controller will shut down. You will be prompted to set it up the next time it is powered on.

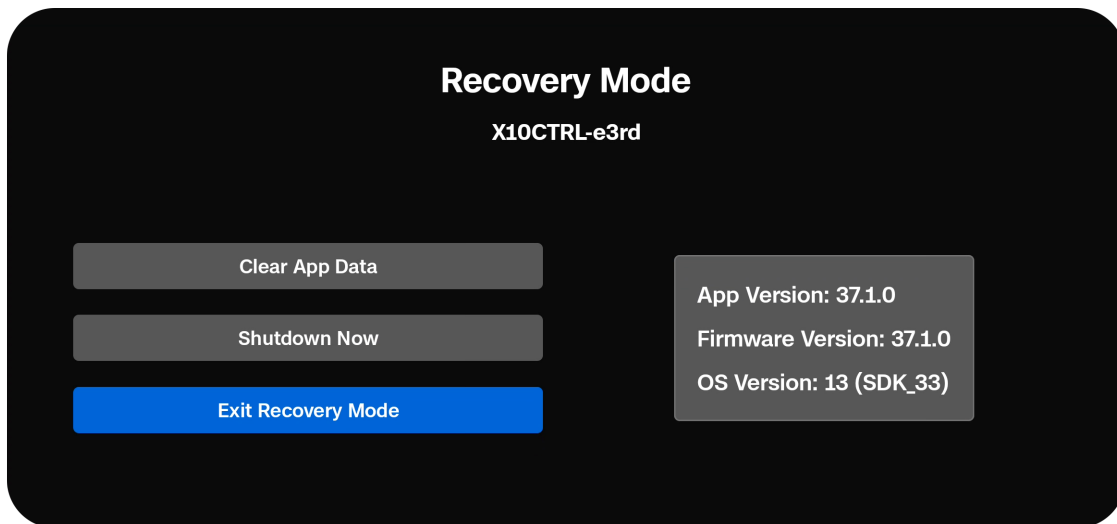



# Legal

### **Safety**

Review the *Skydio Safety and Operating Guide* available at [www.skydio.com/safety](http://www.skydio.com/safety).

### **Battery**

Handle the battery with extreme care and refer to the Operator Manual and to the *Skydio Safety and Operating Guide* for additional information.

Danger of explosion if battery is incorrectly replaced. Replace only with the same or equivalent type recommended by the equipment manufacturer. Carefully dispose of batteries according to manufacturer's instructions and to your local environmental laws and guidelines.

Risque d'explosion si la batterie n'est pas correctement remplacée. Remplacer uniquement par un type identique ou équivalent recommandé par le fabricant de l'équipement. Jeter les batteries conformément aux instructions du fabricant et aux lois et directives environnementales locales.

### **Charging**

Do not use the X10 Dual Charger near wet locations. To avoid the risk of electric shock, use only in dry locations. Do not allow anything to rest on the power cord. Do not locate this device where the cord will be abused by persons working on it. Do not overload wall outlets and extension cords as this can result in fire or electric shock.

N'utiliser pas le X10 Dual Charger à proximité d'endroits humides. Pour éviter tout risque de choc électrique, utiliser uniquement dans des endroits secs. Ne laisser rien reposer sur le cordon d'alimentation. Ne placer pas ce moniteur dans un endroit où le cordon pourrait être maltraité par les personnes travaillant dessus. Ne surcharger pas les prises murales et les rallonges car cela pourrait provoquer un incendie ou un choc électrique.

### **Skydio One (1) Year Limited Warranty**

Skydio warrants the included hardware product against defects in materials and workmanship in hardware under normal use in accordance with published guidelines including but not limited to the *Terms of Use*, *Operator Manual* and the *Skydio Safety and Operating Guide* for one year from the date of delivery (the “Limited Warranty”). The Limited Warranty does not warrant against normal wear and tear or damage caused by accident or abuse and is not applicable to any software provided with the hardware product. The Limited Warranty is subject to the full terms and detailed information about how to obtain service available at [www.skydio.com/legal/limited-warranty](http://www.skydio.com/legal/limited-warranty). If you submit a valid claim under this Limited Warranty, Skydio will either repair, replace, or refund your hardware product at its sole discretion. You may be required to furnish proof of purchase details when making a claim under this Limited Warranty.

### **Skydio Care**

Skydio offers Skydio Care as a subscription service at an additional cost that provides protection from collisions, water damage, or lost drones which are not covered under the Limited Warranty. Skydio Care can be purchased as a one (1) year plan co-extensive with the Limited Warranty, or as a three (3) year plan, which includes a two (2) year extension to the one (1) year term of the Limited Warranty. Skydio Care is subject to the full terms and detailed information about how to obtain service available at <https://www.skydio.com/legal/skydio-care-terms-of-service>. If you submit a valid claim under Skydio Care, you may be eligible to purchase discounted drone replacements for otherwise uncovered damage or losses. The Skydio Care benefits are in addition to the rights provided under the Limited Warranty.

### **California Prop 65 Warnings**

Skydio X10 uses lithium-ion batteries. Exposure to lithium-ion, containing cobalt lithium nickel oxide, and nickel, is known to the State of California to cause cancer and birth defects, or other reproductive harm. For more information visit:

[www.P65Warnings.ca.gov](http://www.P65Warnings.ca.gov).

Skydio X10 Controller contains chemicals including cadmium, which is known to the State of California to cause cancer and birth defects, or other reproductive harm. For more information visit: [www.P65Warnings.ca.gov](http://www.P65Warnings.ca.gov).

Skydio X10 Dual Charger contains chemicals including BPA and nickel, which are known to the State of California to cause cancer and birth defects, or other reproductive harm. For more information visit: [www.P65Warnings.ca.gov](http://www.P65Warnings.ca.gov).

### **FCC Compliance Statement**

These devices comply with Part 15 of the FCC Rules and with ISED Canada license-exempt RSS standard(s). Operation is subject to the following two conditions: (1) these devices may not cause harmful interference, and (2) these devices must accept any interference received, including interference that may cause undesired operation.

Ces appareils sont conformes aux normes RSS exemptes de licence d'ISDE Canada. Leur fonctionnement est soumis aux deux conditions suivantes: (1) ces appareils ne doivent pas causer d'interférences nuisibles, et (2) ces appareils doivent accepter toutes interférences reçues, y compris les interférences susceptibles d'entraîner un fonctionnement indésirable.

Changes or modifications not expressly approved by Skydio could void the user's authority to operate these devices.

These devices have been tested and found to comply with the limits for a Class A digital device, pursuant to part 15 of the FCC Rules. These limits are designed to provide reasonable protection against harmful interference when these devices are operated in a commercial environment. These devices generate, use, and can radiate radio frequency energy and, if not installed and used in accordance with the Operator Manual and Safety and Operating Guide, may cause harmful interference to radio communications. Operation of these devices in a residential area is likely to cause harmful interference in which case the user will be required to correct the interference at his own expense.

This Class A digital apparatus complies with Canadian ICES-003.

Cet appareil numérique de classe A est conforme à la norme Canadienne NMB-003.

# Legal

---

## FAA Compliance Statement

Unless specifically exempt, this product complies with 14 CFR Part 89 regulations on Remote Identification per ASTM F3411-22a-RID-B and ASTM F3586-22.

## Software License

The *Skydio Software End-User License Agreement* available at [www.skydio.com/legal/eula](http://www.skydio.com/legal/eula) governs the use of any Skydio software that is pre-installed, downloaded, installed, or otherwise provided in connection with any included hardware.

## Additional Resources

For all the latest information about Skydio and our products visit: [www.skydio.com](http://www.skydio.com).

For Skydio legal information and product terms of use visit: [www.skydio.com/legal](http://www.skydio.com/legal).

Skydio products are protected by patents and trademarks, registered in the United States and other countries. For Skydio intellectual property information visit: [www.skydio.com/legal/ip](http://www.skydio.com/legal/ip).

© 2026 Skydio, Inc. All rights reserved. Skydio and the Skydio logo are trademarks of Skydio, Inc., registered in the United States and other countries.



#A0534